



US010479592B1

(12) **United States Patent**
Caruso

(10) **Patent No.:** **US 10,479,592 B1**
(45) **Date of Patent:** **Nov. 19, 2019**

- (54) **AEROSOL CANISTER CASE WITH LOCKING TWIST CAP**
- (71) Applicant: **Avanti USA Ltd.**, Tonawanda, NY (US)
- (72) Inventor: **Albert P. Caruso**, Tonawanda, NY (US)
- (*) Notice: Subject to any disclaimer, the term of this patent is extended or adjusted under 35 U.S.C. 154(b) by 0 days.
- (21) Appl. No.: **16/055,843**
- (22) Filed: **Aug. 6, 2018**
- (51) **Int. Cl.**
B65D 83/22 (2006.01)
B65D 83/38 (2006.01)
B65D 83/20 (2006.01)
- (52) **U.S. Cl.**
CPC *B65D 83/22* (2013.01); *B65D 83/201* (2013.01); *B65D 83/388* (2013.01)
- (58) **Field of Classification Search**
CPC B65D 83/22; B65D 83/201
See application file for complete search history.

5,366,118	A *	11/1994	Ciammitti	B65D 83/386 222/153.1
5,379,924	A *	1/1995	Taylor	B65D 83/205 222/402.11
5,458,263	A	10/1995	Ciammitti et al.	
5,531,359	A *	7/1996	Winner	B65D 83/384 222/153.11
5,556,003	A	9/1996	Johnson et al.	
5,971,230	A *	10/1999	Tanaka	B65D 83/205 222/402.1
6,161,736	A *	12/2000	Kaufman	B65D 83/206 222/402.13
6,601,735	B2 *	8/2003	Milian	B05B 11/0027 222/153.11
6,971,552	B2 *	12/2005	Meshberg	B05B 11/3059 222/153.13
7,757,905	B2 *	7/2010	Strand	B65D 83/22 222/153.11
7,922,041	B2	4/2011	Gurrisi et al.	
8,556,125	B2	10/2013	Dapper	
8,622,256	B2	1/2014	Campbell	

(Continued)

Primary Examiner — J C Jacyna
(74) *Attorney, Agent, or Firm* — Simpson & Simpson, PLLC

(56) **References Cited**

U.S. PATENT DOCUMENTS

2,908,244	A	10/1959	Clark	
3,601,290	A *	8/1971	Nigro	B65D 83/205 222/402.11
3,632,024	A *	1/1972	Usen	B65D 83/205 222/402.11
4,871,092	A *	10/1989	Maerte	B05B 11/3008 222/153.13
5,158,206	A *	10/1992	Kobayashi	B65D 47/261 222/153.11

(57) **ABSTRACT**

A case for securing an aerosol canister, including a body, including a first lateral wall having a first top edge and a first bottom edge, a bottom wall connected to the first lateral wall proximate the first bottom edge, and at least one cutout arranged in the first lateral wall proximate the first top edge, and a cap connected to the body, including a nozzle in fluid contact with a stem of the aerosol canister, and at least one gusset arranged to engage the at least one cutout, wherein in an unlocked position, the cap is displaceable in a first axial direction relative to the body to dispense the contents of the aerosol canister out of the nozzle, and in a locked position, the cap is not displaceable in the first axial direction.

20 Claims, 9 Drawing Sheets

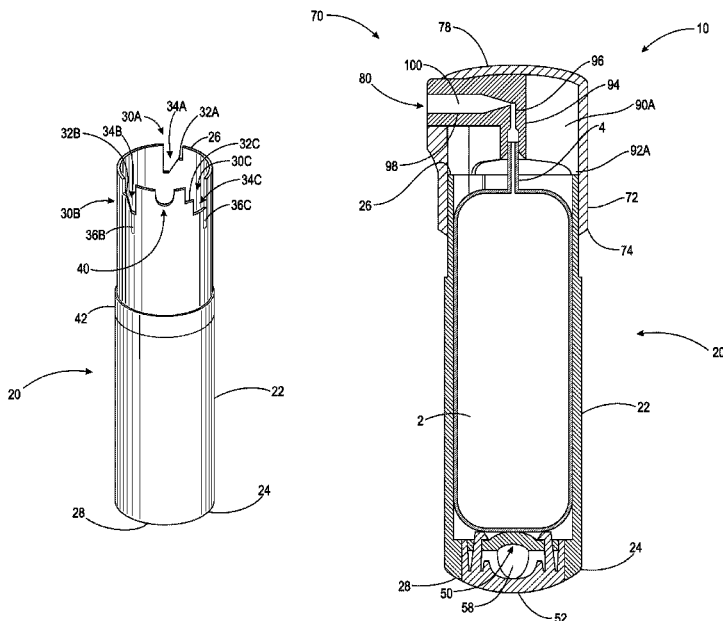

(56)

References Cited

U.S. PATENT DOCUMENTS

8,777,061	B1 *	7/2014	Meshberg	B05B 11/3059 222/153.11
9,205,618	B2	12/2015	Campbell	
9,505,546	B2 *	11/2016	Arora	B65D 83/205
9,803,954	B2	10/2017	Scarr	
2004/0026454	A1 *	2/2004	Meshberg	B05B 11/0032 222/153.14
2005/0017027	A1 *	1/2005	Yerby	B65D 83/206 222/402.13
2014/0252036	A1	9/2014	Ballard	

* cited by examiner

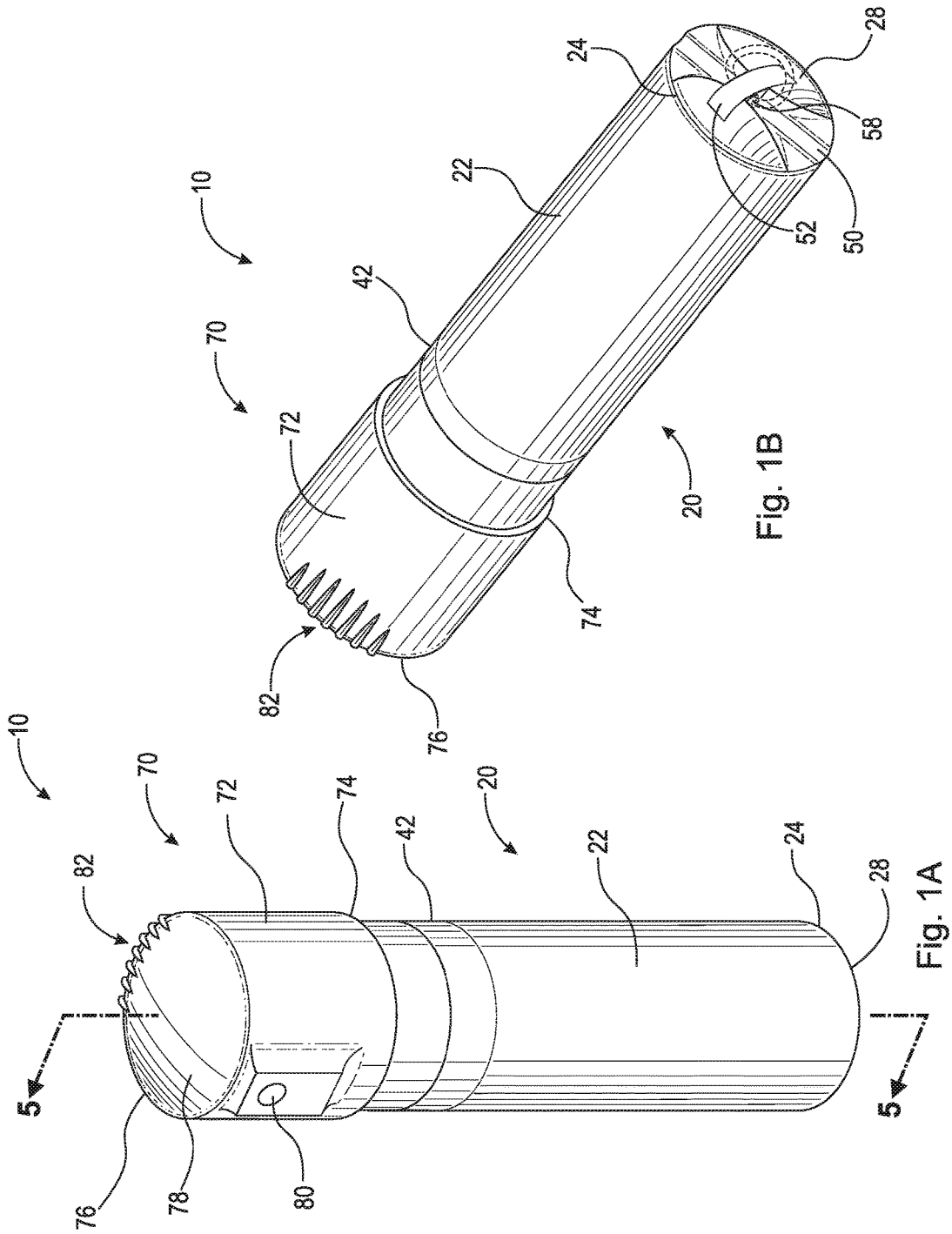

Fig. 1B

Fig. 1A

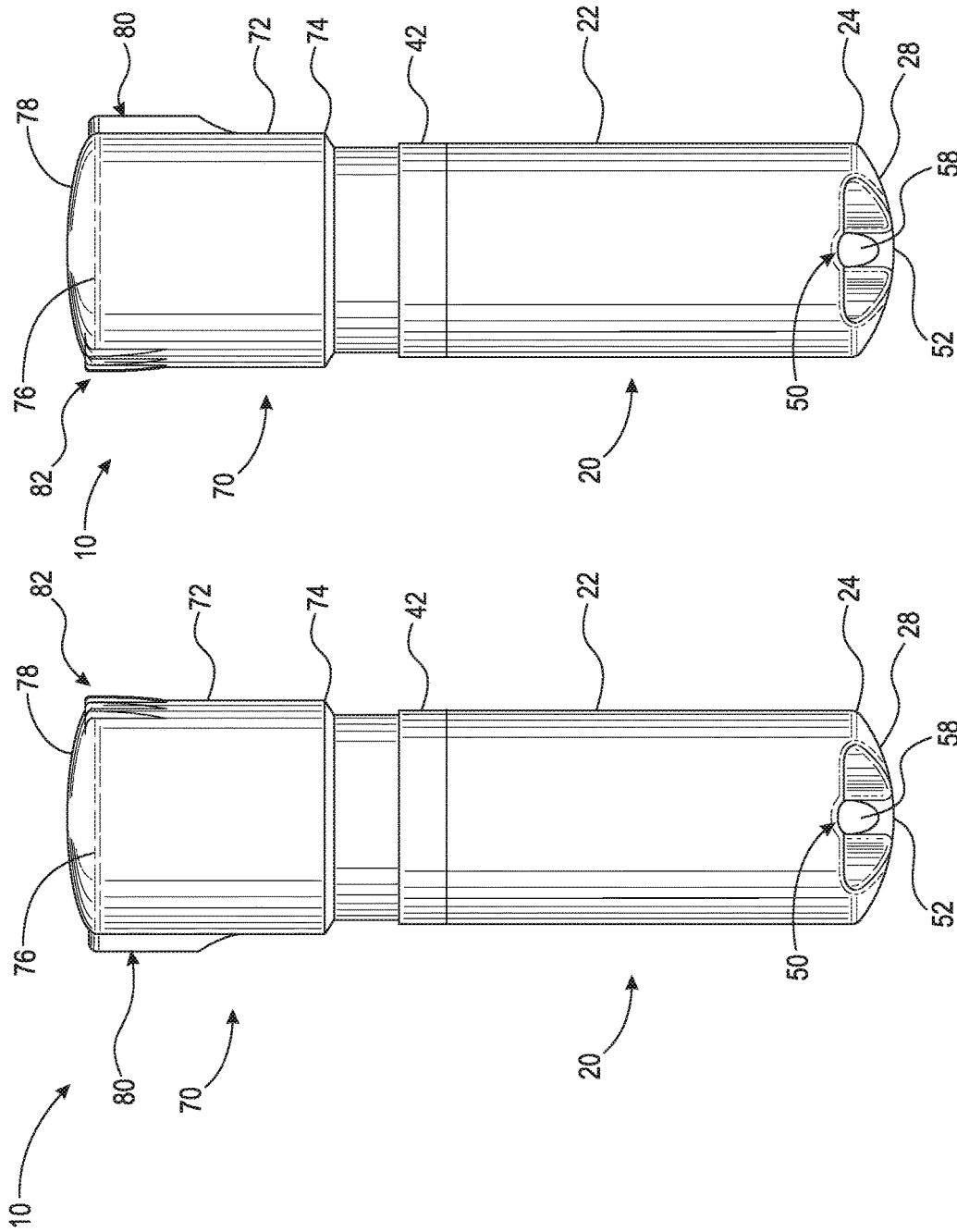

Fig. 2D

Fig. 2C

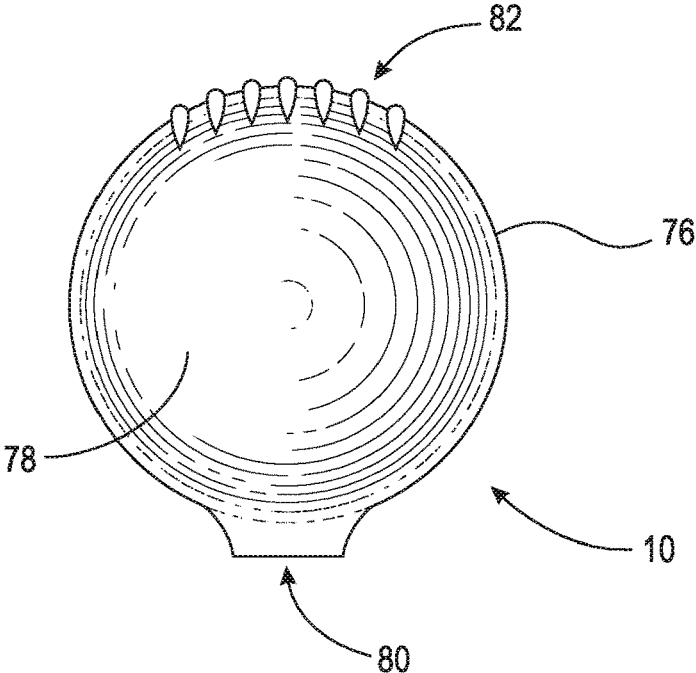

Fig. 2E

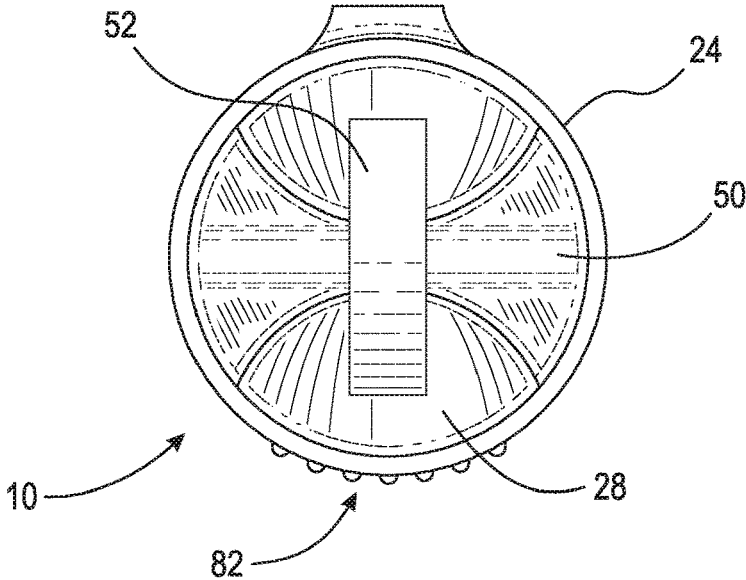

Fig. 2F

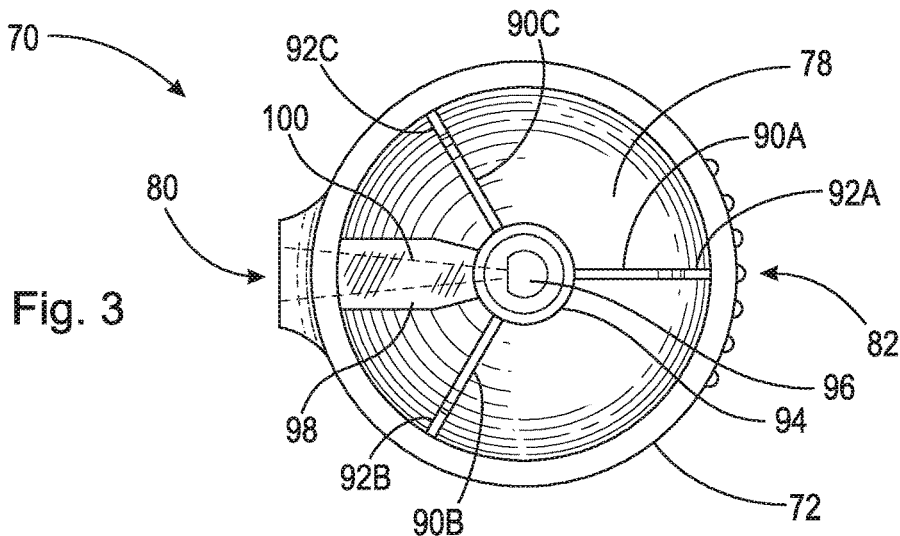

Fig. 3

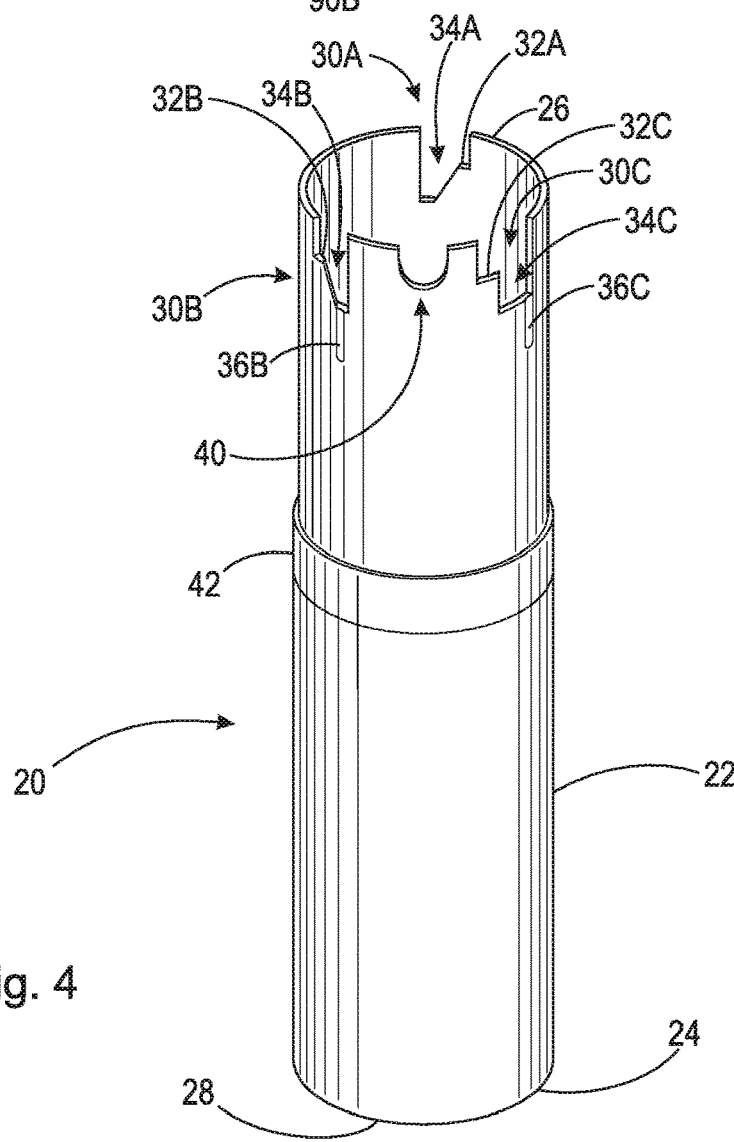

Fig. 4

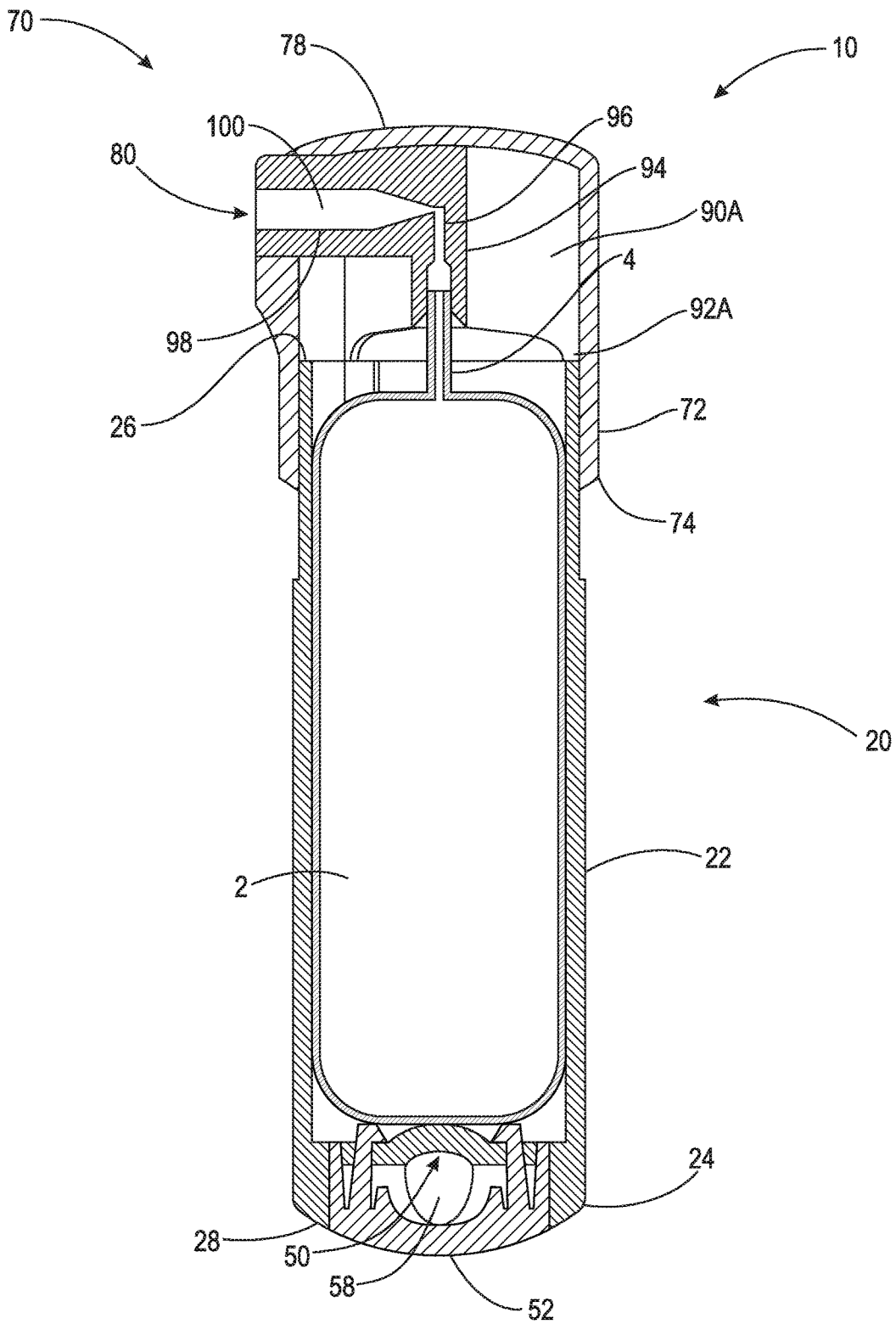

Fig. 5

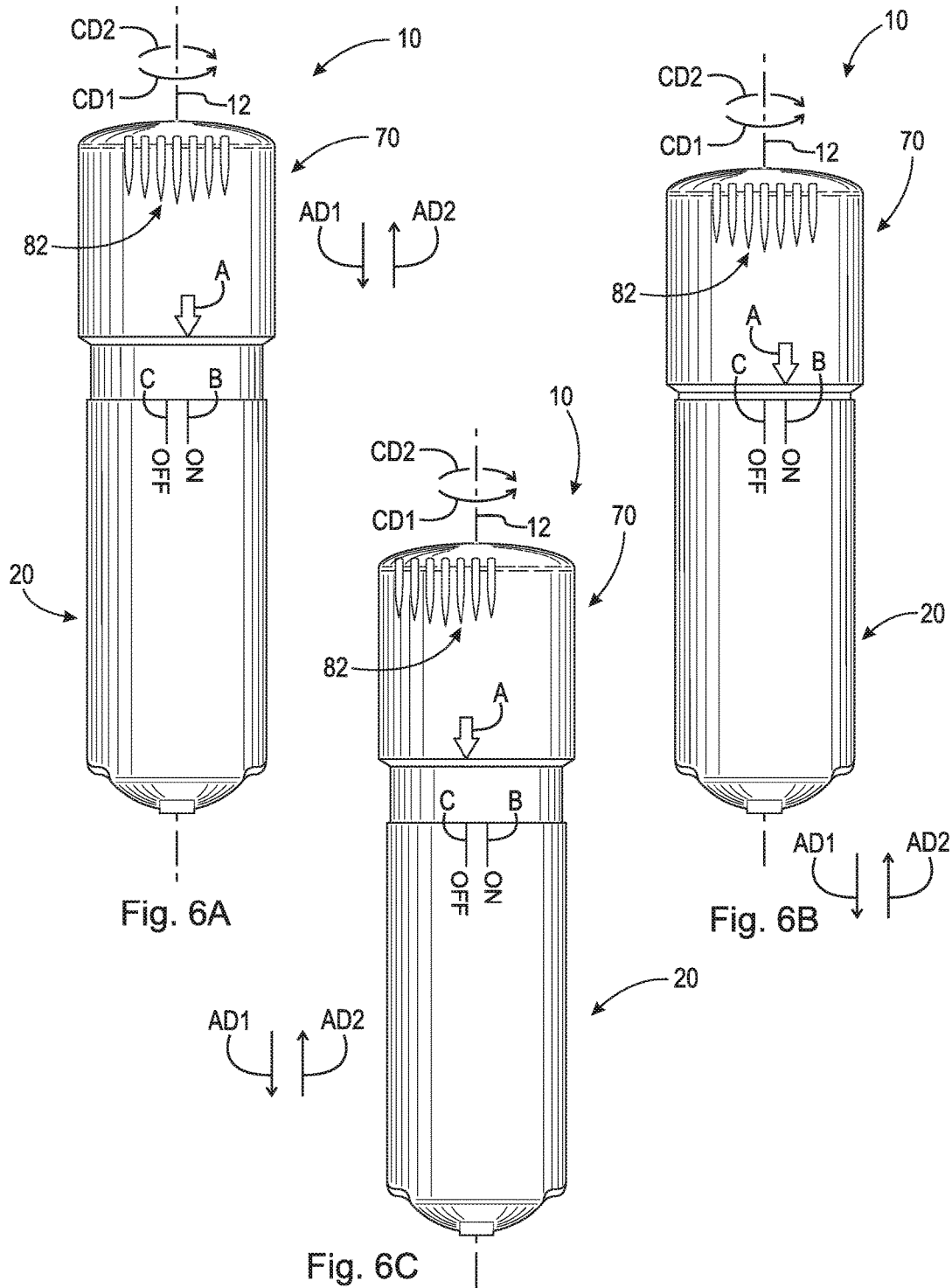

Fig. 6A

Fig. 6B

Fig. 6C

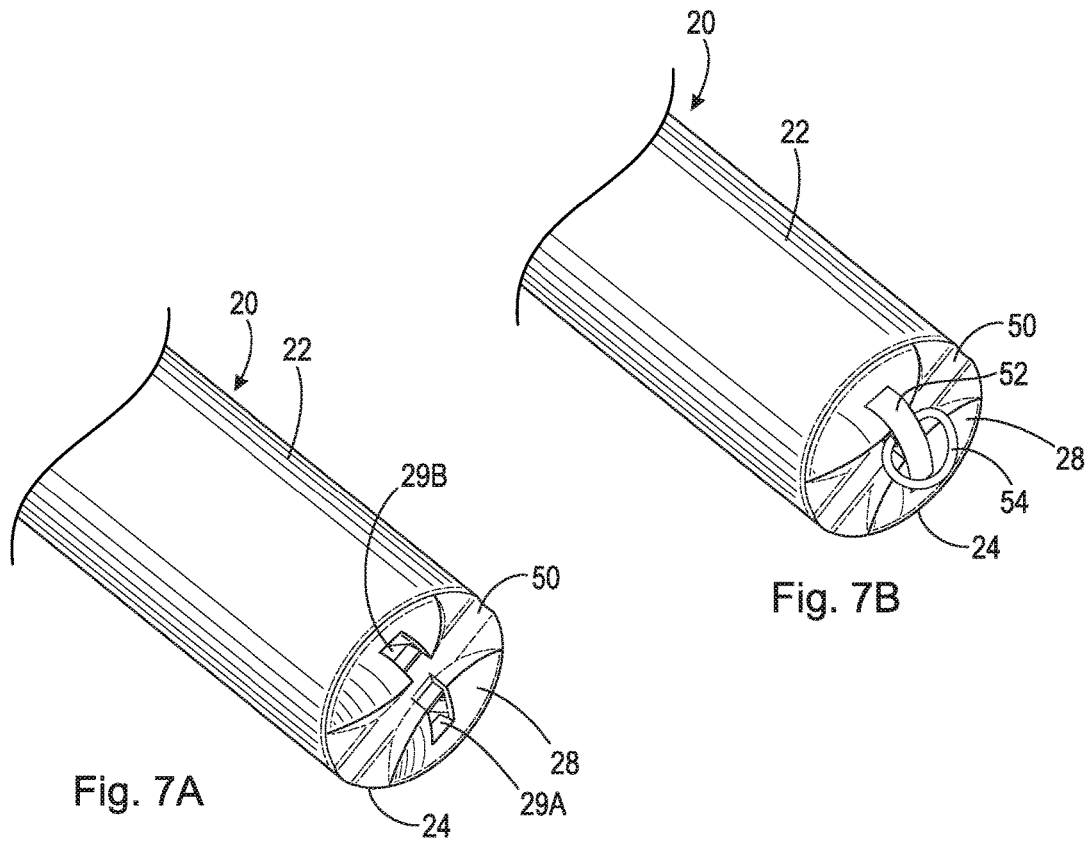

Fig. 7A

Fig. 7B

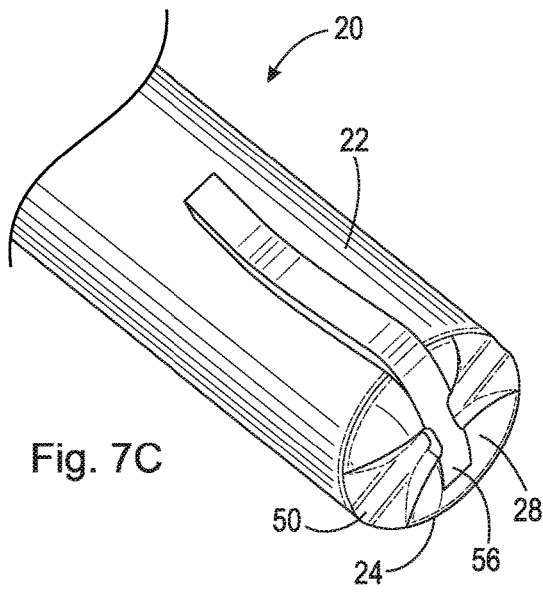

Fig. 7C

Fig. 8A

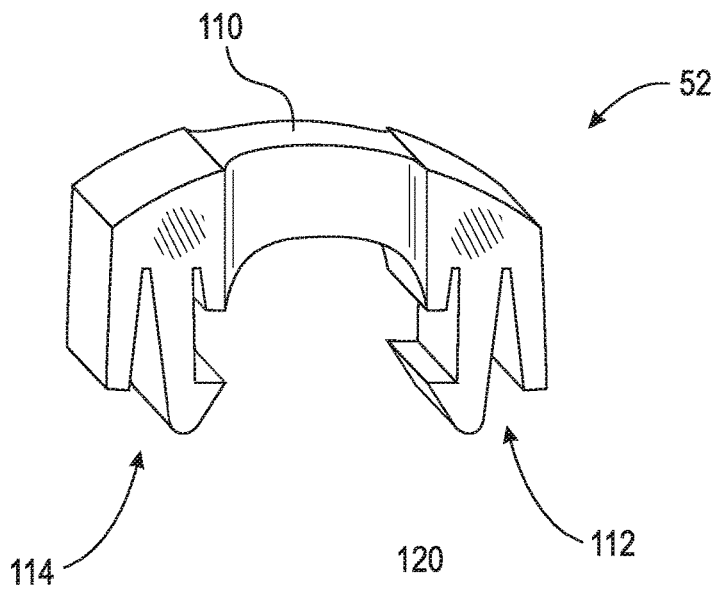
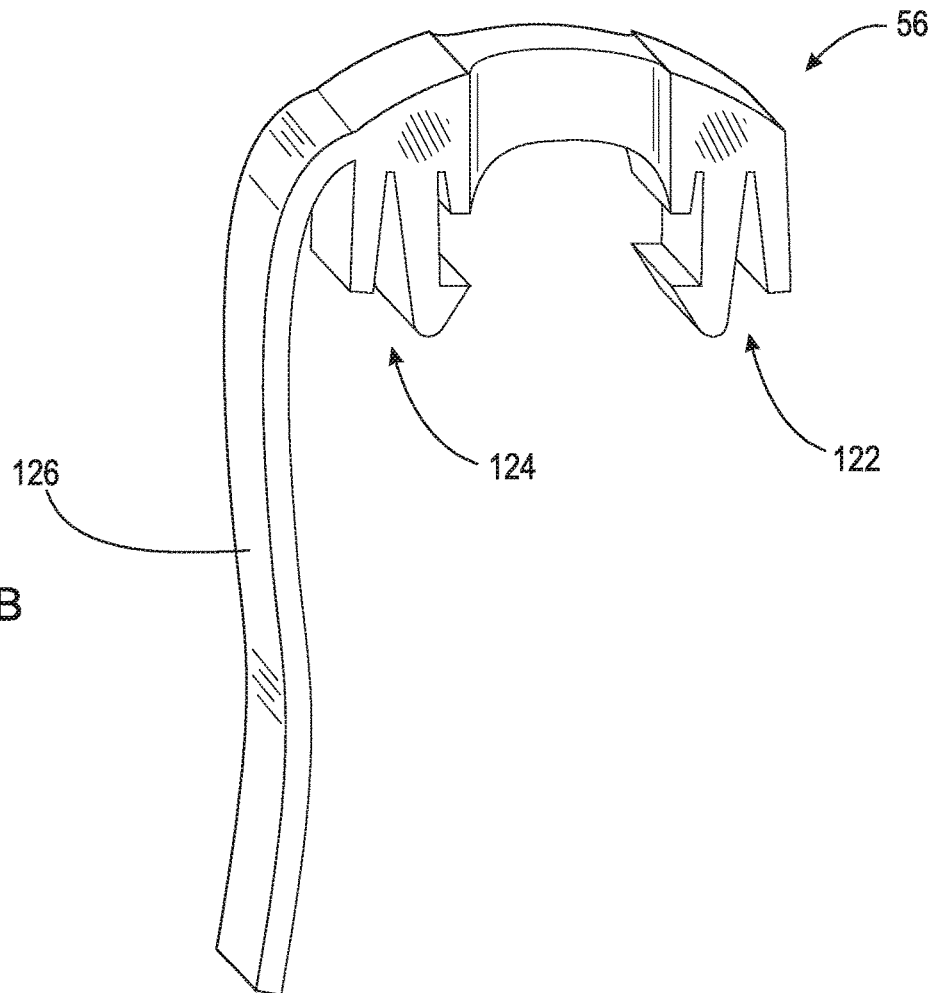

Fig. 8B



1

AEROSOL CANISTER CASE WITH LOCKING TWIST CAP

FIELD

The invention relates generally to a case for an aerosol canister, and, more specifically, to a case having a cap that rotates to lock and unlock.

BACKGROUND

Cases for aerosol or spray canisters typically include an actuator to engage the stem of the canister in order to dispel the canister's contents. There are a variety of aerosol dispensers that are used in many applications which include dispensing perfume, air fresheners, personal hygiene products, covering an article with a coat of paint, and dispensing cleaning products, amongst others. One specific application for an aerosol dispenser is as a personal defense device that, for example, directs a chemical repellent spray towards a potential human or animal threat.

Typical aerosol canisters come in a cylindrical shape with no way of securing it to the user's body. With respect to personal defense devices, easy access to dispensing the contents of the canister is crucial to ensure the safety of the user when a threat presents itself. However, the reason personal defense devices are effective is because their chemical contents are indiscriminately extremely painful to anyone who comes into contact with it. Thus, it is important that the user has quick access to the canister without having to carry it in hand. Additionally, it is important to be able to lock the canister to prevent contents from inadvertently or unintentionally dispensing.

Therefore, there is a long-felt need for an improved aerosol canister case that can be easily locked and unlocked as well as easily attachable to a user's clothing such that it is easily accessible.

SUMMARY

According to aspects illustrated herein, there is provided a case for securing an aerosol canister, comprising a body, including a first lateral wall having a first top edge and a first bottom edge, a bottom wall connected to the first lateral wall proximate the first bottom edge, and at least one cutout arranged in the first lateral wall proximate the first top edge, and a cap connected to the body, including a second lateral wall having a second top edge and a second bottom edge, a top wall connected to the second lateral wall proximate the second top edge, a nozzle in fluid contact with a stem of the aerosol canister, and at least one gusset arranged to engage the at least one cutout, wherein in an unlocked position, the cap is displaceable in a first axial direction relative to the body to dispense the contents of the aerosol canister out of the nozzle, and in a locked position, the cap is not displaceable in the first axial direction.

According to aspects illustrated herein, there is provided a case for securing an aerosol canister, comprising a body, including a first lateral wall having a first top edge and a first bottom edge, a bottom wall connected to the first lateral wall proximate the first bottom edge, and at least one cutout arranged in the first lateral wall proximate the first top edge, and a cap connected to the body, the cap concentrically arranged around the body proximate the first top edge and including a second lateral wall having a second top edge and a second bottom edge, a top wall connected to the second lateral wall proximate the second top edge, a nozzle in fluid

2

contact with a stem of the aerosol canister, and at least one gusset arranged to engage the at least one cutout, wherein in an unlocked position, the cap is displaceable in a first axial direction relative to the body to dispense the contents of the aerosol canister out of the nozzle, and in a locked position, the cap is not displaceable in the first axial direction.

These and other objects, features, and advantages of the present disclosure will become readily apparent upon a review of the following detailed description of the disclosure, in view of the drawings and appended claims.

BRIEF DESCRIPTION OF THE DRAWINGS

Various embodiments are disclosed, by way of example only, with reference to the accompanying schematic drawings in which corresponding reference symbols indicate corresponding parts, in which:

FIG. 1A is a top perspective view of a case;

FIG. 1B is a bottom perspective view of the case shown in FIG. 1A;

FIG. 2A is a front elevational view of the case shown in FIG. 1A;

FIG. 2B is a rear elevational view of the case shown in FIG. 1A;

FIG. 2C is a right side elevational view of the case shown in FIG. 1A;

FIG. 2D is a left side elevational view of the case shown in FIG. 1A;

FIG. 2E is a top elevational view of the case shown in FIG. 1A;

FIG. 2F is a bottom elevational view of the case shown in FIG. 1A;

FIG. 3 is a bottom elevational view of a cap as shown in FIG. 1A;

FIG. 4 is a top perspective view of a body as shown in FIG. 1A;

FIG. 5 is a cross-sectional view of the case taken generally along line 5-5 in FIG. 1A;

FIG. 6A is a rear elevational view of the case as shown in FIG. 1A, with the cap arranged in an unlocked position;

FIG. 6B is a rear elevational view of the case as shown in FIG. 6A, with the cap depressed relative to the body;

FIG. 6C is a rear elevational view of the case as shown in FIG. 1A, with the cap arranged in a locked position;

FIG. 7A is a bottom perspective view of the case as shown in FIG. 1A with the attachment element removed;

FIG. 7B is a bottom perspective view of the case as shown in FIG. 7A with a ring attachment secured thereto;

FIG. 7C is a bottom perspective view of the case as shown in FIG. 7A with a clip attachment secured thereto;

FIG. 8A is a perspective view of a ring attachment as shown in FIG. 7B; and,

FIG. 8B is a perspective view of a clip attachment as shown in FIG. 7C.

DETAILED DESCRIPTION

At the outset, it should be appreciated that like drawing numbers on different drawing views identify identical, or functionally similar, structural elements. It is to be understood that the claims are not limited to the disclosed aspects.

Furthermore, it is understood that this disclosure is not limited to the particular methodology, materials and modifications described and as such may, of course, vary. It is also understood that the terminology used herein is for the purpose of describing particular aspects only, and is not intended to limit the scope of the claims.

Unless defined otherwise, all technical and scientific terms used herein have the same meaning as commonly understood to one of ordinary skill in the art to which this disclosure pertains. It should be understood that any methods, devices or materials similar or equivalent to those described herein can be used in the practice or testing of the example embodiments.

It should be appreciated that the term “substantially” is synonymous with terms such as “nearly,” “very nearly,” “about,” “approximately,” “around,” “bordering on,” “close to,” “essentially,” “in the neighborhood of,” “in the vicinity of,” etc., and such terms may be used interchangeably as appearing in the specification and claims. It should be appreciated that the term “proximate” is synonymous with terms such as “nearby,” “close,” “adjacent,” “neighboring,” “immediate,” “adjoining,” etc., and such terms may be used interchangeably as appearing in the specification and claims. The term “approximately” is intended to mean values within ten percent of the specified value.

By “non-rotatably connected” elements, we mean that: the elements are connected so that whenever one of the elements rotate, all the elements rotate; and relative rotation between the elements is not possible. Radial and/or axial movement of non-rotatably connected elements with respect to each other is possible, but not required. By “rotatably connected” elements, we mean that the elements are rotatable with respect to each other.

Adverting now to the figures, FIG. 1A is a top perspective view of case 10. FIG. 1B is a bottom perspective view of case 10. FIG. 2A is a front elevational view of case 10. FIG. 2B is a rear elevational view of case 10. FIG. 2C is a right side elevational view of case 10. FIG. 2D is a left side elevational view of case 10. FIG. 2E is a top elevational view of case 10. FIG. 2F is a bottom elevational view of case 10. FIG. 3 is a bottom elevational view of cap 70. FIG. 4 is a top perspective view of body 20. FIG. 5 is a cross-sectional view of case 10 taken generally along line 5-5 in FIG. 1A. The following description should be read in view of FIGS. 1-5. Case 10 generally comprises body 20 and cap 70.

Body 20 comprises lateral wall 22 and bottom wall 28. Lateral wall 22 is generally cylindrical having a circular cross section and comprises edge 24 and edge 26. It should be appreciated that lateral wall 22 may be any shape suitable for housing a canister (e.g., an aerosol canister), such as a triangular, rectangular, square, octagonal, hexagonal, ovalar, ellipsoidal, or polygonal geometry. Bottom wall 28 is connected to lateral wall 22 at edge 24. Bottom wall 28 may be planar or curvilinear and includes channel 50. Bottom wall 28 is arranged to engage a connection element (e.g., ring attachment 52 or clip attachment 56) and will be discussed in greater detail below. Hole 58 is formed between the connection element and channel 50. Lateral wall 22 comprises, proximate edge 26, cutouts 30A, 30B, 30C, and 40, as shown in FIG. 4. Cutouts 30A-C are generally equidistantly circumferentially spaced from each other, for example, at 0°, 120°, and 240°. In some embodiments, cutouts 30A-C are not equidistantly circumferentially spaced. It should be appreciated that cutouts 30A-C may be arranged at any location along edge 26 suitable for engagement with respective gussets, as will be described in greater detail below. Furthermore, it should be appreciated that body 20 may have any number of cutouts, for example, one or more, suitable for engagement with respective gussets. Cutout 30A extends axially from edge 26 and comprises ledge 32A and notch 34A. Ledge 32A is substantially parallel to edge 26. In some embodiments, ledge 32A is non-parallel to edge 26. Notch 34A is generally V-shaped; however, it

should be appreciated that notch 34A may comprise any geometry suitable for engagement with respective gussets, as will be discussed in greater detail below, such as rectangular, ovalar, ellipsoidal, square, etc. Cutout 30B extends axially from edge 26 and comprises ledge 32B and notch 34B. As shown in FIG. 4, cutout 30B is substantially similar to cutout 30A. Ledge 32B is substantially parallel to edge 26. In some embodiments, ledge 32B is non-parallel to edge 26. Notch 34B is generally V-shaped; however, it should be appreciated that notch 34B may comprise any geometry suitable for engagement with respective gussets, as will be discussed in greater detail below, such as rectangular, ovalar, ellipsoidal, square, etc. Cutout 30C extends axially from edge 26 and comprises ledge 32C and notch 34C. Ledge 32C is substantially parallel to edge 26. In some embodiments, ledge 32C is non-parallel to edge 26. Notch 34C is generally rectangular-shaped; however, it should be appreciated that notch 34C may comprise any geometry suitable for engagement with respective gussets, as will be discussed in greater detail below, such as V-shaped, ovalar, ellipsoidal, square, etc. Cutout 40 extends axially from edge 26 and is arranged for engagement with outlet conduit 98. Cutout 40 is generally semicircular-shaped; however, it should be appreciated that notch 40 may comprise any geometry suitable for engagement with outlet conduit 98, such as rectangular, ovalar, ellipsoidal, square, etc. In the embodiment shown, cutout 40 is arranged circumferentially between cutouts 30B and 30C. In some embodiments, body 20 may further comprise grooves 36A (not shown), 36B, and 36C, arranged proximate and/or adjacent to notches 34A, 34B, and 34C, respectively. In some embodiments, body 20 may further comprise rib 42 circumferentially arranged around lateral wall 72.

Cap 70 comprises lateral wall 72 and top wall 78. Lateral wall 72 is generally cylindrical having a circular cross section and comprises edge 74 and edge 76. It should be appreciated that lateral wall 72 may be any shape suitable for housing a canister (e.g., an aerosol canister) and slidably engaging and connecting to body 20, such as a triangular, rectangular, square, octagonal, hexagonal, ovalar, ellipsoidal, or polygonal geometry. Top wall 78 is connected to lateral wall 72 at edge 76. Top wall 78 may be planar or curvilinear. Lateral wall 72 comprises, proximate edge 26, nozzle 80 and one or more ribs 82. Nozzle 80 is generally a hole that extends through lateral wall 72 to outlet conduit 98 for dispersing of the contents of the canister. Ribs 82 are arranged substantially diametrically opposed to nozzle 80. Ribs 82 are arranged to provide the user with grip and also a general sense of which direction nozzle 80 is directed (i.e., nozzle 80 is arranged 180° from ribs 82). The user may place a thumb or finger on ribs 82, and rotate cap 70 with respect to body 20 in order to lock/unlock case 10, as will be discussed in greater detail below. As shown in FIG. 3, cap 70 further comprises outlet conduit 98, inlet conduit 94, and gussets 90A-C. Inlet conduit 94 is generally arranged concentric to lateral wall 72. Inlet 94 is connected to top wall 78 and comprises hole 96. Outlet conduit 98 is connected to top wall 78 and extends from inlet conduit 94 to nozzle 80. Outlet conduit 98 comprises hole 100 which is connected to hole 96 and nozzle 80. Inlet conduit 94 is arranged to connect to stem 4 of aerosol canister 2, as shown in FIG. 5. Hole 96, hole 100, and nozzle 80 provide a passage for the contents of aerosol canister 2 to be dispersed from stem 4 (when actuated), out of cap 70.

Gusset 90A is connected to top wall 78 and extends from inlet conduit 94 to lateral wall 72. Gusset 90A increases the strength of cap 70 and also is arranged to engage cutout 30A.

5

Specifically, gusset 90A comprises downwardly projecting protrusion 92A which engages either notch 34A, when cap 70 is in the unlocked position, or ledge 32A, when cap 70 is in the locked position. Gusset 90B is connected to top wall 78 and extends from inlet conduit 94 to lateral wall 72. Gusset 90B increases the strength of cap 70 and also is arranged to engage cutout 30B. Specifically, gusset 90B comprises downwardly projecting protrusion 92B which engages either notch 34B, when cap 70 is in the unlocked position, or ledge 32B, when cap 70 is in the locked position. Gusset 90C is connected to top wall 78 and extends from inlet conduit 94 to lateral wall 72. Gusset 90C increases the strength of cap 70 and also is arranged to engage cutout 30C. Specifically, gusset 90C comprises downwardly projecting protrusion 92C which engages either notch 34C, when cap 70 is in the unlocked position, or ledge 32C, when cap 70 is in the locked position. It should be appreciated that cap 70 may comprise any number of gussets, for example one or more gussets, suitable to engage one or more cutouts of body 20 and lock and unlock cap 70 axially with respect to body 20. Additionally, in some embodiments the gussets do not include downwardly projecting protrusions, but rather the gussets themselves interact and engage the cutouts of body 20. Gussets 90A-C may comprise any geometric shape suitable to engage cutouts 30A-C, respectively.

Cap 70 is arranged to be concentrically engaged around body 20. Cap 70 is capable of translational movement, that is, movement in axial directions AD1 and AD2 with respect to body 20, as well as rotational movement, that is, movement in circumferential directions CD1 and CD2. When engaged, cap 70 may be limited in axial movement with respect to body 20. When cap 70 is in the locked position, downwardly projecting protrusion 92A abuts against or substantially against ledge 32A, preventing cap 70 from being displaced axially relative to body 20. When cap 70 is in the unlocked position, downwardly projecting protrusions 92A-C are circumferentially aligned with notches 34A-C, respectively, which allows cap 70 to be axially displaced relative to body 20. When cap 70 is displaced axially relative to body 20, inlet conduit 94 engages and displaces stem 4, which allows the contents of aerosol canister 2 to be dispensed through hole 96, hole 100, and out through nozzle 80.

FIG. 6A is a rear elevational view of case 10 with cap 70 arranged in an unlocked position. In the unlocked position, arrow A on cap 70 is circumferentially aligned with position B (e.g., the ON position) of body 20. In the unlocked position, gussets 90A-C are aligned with notches 34A-C of cutouts 30A-C, respectively, which allows cap 70 to be displaced in axial direction AD1 with respect to body 20. To arrange case 10 in the unlocked position, cap 70 is rotated in circumferential direction CD1 until arrow A is aligned with position B. The engagement of gussets 90A-C with cutouts 30A-C only allow cap 70 to be rotated from position C to position B and back to position C. In some embodiments, cutouts 30A-C do not limit circumferential movement between cap 70 and body 20. Cap 70 may be rotated via the user's thumb or finger. While the user holds body 20 in the hand, the user places the thumb on ribs 82 and rotates cap 70 in either circumferential direction CD1 or circumferential direction CD2 depending on the desired position.

FIG. 6B is a rear elevational view of case 10 with cap 70 depressed relative to body 20. In the unlocked position, cap 70 is displaced in axial direction AD1 relative to body 20, which causes inlet conduit 94 to engage stem 4, thus dispensing the contents of aerosol canister 2 through hole 96, hole 100, and out through nozzle 80. Cap 70 may, for

6

example, be displaced by a user's thumb or finger, which is arranged on ribs 82. Once the user releases the pressure applied in axial direction AD1 to cap 70, stem 4 forces cap 70 in axial direction AD2 back to its original position. In some embodiments, cap 70 comprises a spring or other resilient element arranged between cap 70 and aerosol canister 2 to return cap 70 to its original position after pressure to cap 70 has been removed.

FIG. 6C is a rear elevational view of case 10 with cap 70 arranged in a locked position. In the locked position, arrow A on cap 70 is circumferentially aligned with position C (e.g., the OFF position) of body 20. In the locked position, gussets 90A-C are aligned with ledges 32A-C of cutouts 30A-C, respectively, which prevents cap 70 from being displaced in axial direction AD1 with respect to body 20. To arrange case 10 in the locked position, cap 70 is rotated in circumferential direction CD2 until arrow A is aligned with position C.

FIG. 7A is a bottom perspective view of case 10 with the attachment element removed. As shown, bottom wall 28 comprises channel 50 and holes 29A-B. Holes 29A-B allow for attachment of an attachment element to body 20 such that case 10 may be easily connected to, for example, a key chain or an article of clothing. Hole 58 is formed between the attachment element and channel 50. FIG. 7B is a bottom perspective view of case 10 with ring attachment 52 secured thereto. Ring 54 may be secured to ring attachment 52 for connection to, for example, a key chain. In some embodiments, a string, wire, cable, chain, etc. is secure to ring attachment 52. FIG. 7C is a bottom perspective view of case 10 with clip attachment 56 secured thereto. Clip attachment 56 allows case 10 to be secured to, for example, a user's pocket or belt.

FIG. 8A is a perspective view of ring attachment 52. Ring attachment 52 generally comprises arm 110 and prongs 112 and 114. To secure ring attachment 52 to body 20, prongs 112 and 114 are engaged with holes 29A-B. FIG. 8B is a perspective view of clip attachment 56. Clip attachment 56 generally comprises arm 120, prongs 122 and 124, and clip 126. To secure clip attachment 56 to body 20, prongs 122 and 124 are engaged with holes 29A-B.

It will be appreciated that various aspects of the disclosure above and other features and functions, or alternatives thereof, may be desirably combined into many other different systems or applications. Various presently unforeseen or unanticipated alternatives, modifications, variations, or improvements therein may be subsequently made by those skilled in the art which are also intended to be encompassed by the following claims.

LIST OF REFERENCE NUMERALS

2	Aerosol canister
4	Stem
10	Case
12	Axis
20	Body
22	Lateral wall
24	Edge
26	Edge
28	Bottom wall
29A	Hole
29B	Hole
30A	Cutout
30B	Cutout
30C	Cutout
32A	Ledge

- 32B Ledge
- 32C Ledge
- 34A Notch
- 34B Notch
- 34C Notch
- 36A Groove
- 36B Groove
- 36C Groove
- 40 Cutout
- 42 Rib
- 50 Channel
- 52 Ring attachment
- 54 Ring
- 56 Clip attachment
- 58 Hole
- 70 Cap
- 72 Lateral wall
- 74 Edge
- 76 Edge
- 78 Top wall
- 80 Nozzle
- 82 Ribs
- 90A Gusset
- 90B Gusset
- 90C Gusset
- 92A Downwardly projecting protrusion
- 92B Downwardly projecting protrusion
- 92C Downwardly projecting protrusion
- 94 Inlet conduit
- 96 Hole
- 98 Outlet conduit
- 100 Hole
- 110 Arm
- 112 Prong
- 114 Prong
- 120 Arm
- 122 Prong
- 124 Prong
- 126 Clip
- A Arrow
- B Position
- C Position
- AD1 Axial direction
- AD2 Axial direction
- CD1 Circumferential direction
- CD2 Circumferential direction

What is claimed is:

1. A case for securing an aerosol canister, comprising:
 - a body, including:
 - a first lateral wall having a first top edge and a first bottom edge;
 - a bottom wall connected to and enclosing the first lateral wall proximate the first bottom edge; and,
 - at least one cutout arranged in the first lateral wall proximate the first top edge; and,
 - a cap rotatably connected to the body, including:
 - a second lateral wall having a second top edge and a second bottom edge;
 - a top wall connected to the second lateral wall proximate the second top edge;
 - a nozzle in fluid contact with a stem of the aerosol canister; and,
 - at least one gusset arranged to engage the at least one cutout;

- wherein:
- in an unlocked position, the cap is displaceable in a first axial direction relative to the body to dispense the contents of the aerosol canister out of the nozzle; and,
 - in a locked position, the cap is not displaceable in the first axial direction.
2. The case as recited in claim 1, wherein the at least one cutout comprises a ledge and a notch.
 3. The case as recited in claim 2, wherein:
 - in the unlocked position, the gusset is arranged to engage the notch; and,
 - in the locked position, the gusset is arranged to engage the ledge.
 4. The case as recited in claim 3, wherein:
 - to arrange the case in the unlocked position, the cap is rotated in a first circumferential direction relative to the body; and,
 - to arrange the case in the locked position, the cap is rotated in a second circumferential direction, opposite the first circumferential direction, relative to the body.
 5. The case as recited in claim 1, wherein the cap further comprises a conduit:
 - including a hole;
 - connected to the nozzle; and,
 - arranged to engage the stem.
 6. The case as recited in claim 5, wherein the conduit comprises:
 - an inlet conduit having a first hole, the inlet conduit arranged to engage the stem; and,
 - an outlet conduit having a second hole, the second hole extending from the first hole to the nozzle.
 7. The case as recited in claim 1, wherein the at least one gusset extends between the top wall and the second lateral wall.
 8. The case as recited in claim 1, wherein the cap is arranged concentrically around the body.
 9. The case as recited in claim 1, wherein the cap comprises one or more ribs arranged proximate the second top edge.
 10. The case as recited in claim 9, wherein the one or more ribs are arranged diametrically opposite the nozzle.
 11. The case as recited in claim 1, wherein the bottom wall is curvilinear and is arranged for connection to an attachment element.
 12. The case as recited in claim 11, wherein:
 - the bottom wall includes a channel; and,
 - a hole is formed between the attachment element and the channel.
 13. A case for securing an aerosol canister, comprising:
 - a body, including:
 - a first lateral wall having a first top edge and a first bottom edge;
 - a bottom wall connected to the first lateral wall proximate the first bottom edge, the bottom wall enclosing the first bottom edge; and,
 - at least one cutout arranged in the first lateral wall proximate the first top edge; and,
 - a cap connected to the body, the cap concentrically arranged around the body proximate the first top edge and including:
 - a second lateral wall having a second top edge and a second bottom edge;
 - a top wall connected to the second lateral wall proximate the second top edge;
 - a nozzle in fluid contact with a stem of the aerosol canister; and,

9

at least one gusset arranged to engage the at least one cutout;
wherein:

in an unlocked position, the cap is displaceable in a first axial direction relative to the body to dispense the contents of the aerosol canister out of the nozzle; and,

in a locked position, the cap is not displaceable in the first axial direction.

14. The case as recited in claim 13, wherein the at least one cutout comprises a ledge and a notch.

15. The case as recited in claim 14, wherein:

in the unlocked position, the gusset is arranged to engage the notch; and,

in the locked position, the gusset is arranged to engage the ledge.

16. The case as recited in claim 15, wherein:

to arrange the case in the unlocked position, the cap is rotated in a first circumferential direction relative to the body; and,

10

to arrange the case in the locked position, the cap is rotated in a second circumferential direction, opposite the first circumferential direction, relative to the body.

17. The case as recited in claim 13, wherein the cap further comprises a conduit:

including a hole; connected to the nozzle; and, arranged to engage the stem.

18. The case as recited in claim 17, wherein the conduit comprises:

an inlet conduit having a first hole, the inlet conduit arranged to engage the stem; and, an outlet conduit having a second hole, the second hole extending from the first hole to the nozzle.

19. The case as recited in claim 13, wherein the at least one gusset extends between the top wall and the second lateral wall.

20. The case as recited in claim 13, wherein: the bottom wall includes a channel; and, a hole is formed between an attachment element and the channel.

* * * * *