



US012616320B2

(12) **United States Patent**
Jhunjunwala

(10) **Patent No.:** **US 12,616,320 B2**
(45) **Date of Patent:** **May 5, 2026**

(54) **MATTRESS COVER**
(71) Applicant: **Sachin Jhunjunwala**, Maharashtra (IN)
(72) Inventor: **Sachin Jhunjunwala**, Maharashtra (IN)
(*) Notice: Subject to any disclaimer, the term of this patent is extended or adjusted under 35 U.S.C. 154(b) by 0 days.
(21) Appl. No.: **18/778,119**
(22) Filed: **Jul. 19, 2024**
(65) **Prior Publication Data**
US 2025/0366639 A1 Dec. 4, 2025

4,723,330 A * 2/1988 Kellogg A47C 27/085 5/497
4,924,543 A * 5/1990 Hoss A47G 9/02 5/490
4,980,941 A * 1/1991 Johnson, III A47G 9/0246 5/497
5,029,353 A * 7/1991 Kimball A47G 9/0246 5/497
5,165,128 A * 11/1992 Honig A47G 9/0246 5/482
5,177,821 A * 1/1993 Kawtoski A47G 9/0246 5/482
5,729,847 A * 3/1998 Allardice A47G 9/02 5/500
8,813,280 B1 * 8/2014 Arora A47G 9/0246 5/482
8,997,280 B1 * 4/2015 Hannula A47C 31/105 5/500

(Continued)

(30) **Foreign Application Priority Data**
May 30, 2024 (IN) 202421042159
(51) **Int. Cl.**
A47G 9/02 (2006.01)
(52) **U.S. Cl.**
CPC **A47G 9/0246** (2013.01)
(58) **Field of Classification Search**
CPC A47G 9/02; A47G 9/0238; A47G 9/0246; A47C 31/105
USPC 5/497
See application file for complete search history.

FOREIGN PATENT DOCUMENTS

WO 2008042082 A2 4/2008
Primary Examiner — J. T. Newton
(74) *Attorney, Agent, or Firm* — Simpson & Simpson, PLLC

(56) **References Cited**
U.S. PATENT DOCUMENTS
2,162,755 A * 6/1939 Shauer A47G 9/0246 38/140
2,195,039 A * 3/1940 Shauer A47G 9/0246 5/497

(57) **ABSTRACT**
A mattress cover (100) for a mattress includes a sheet (102) configured to enclose the mattress at least partially. The sheet (102) comprises an upper portion (104) to cover a top side of the mattress. Further, the sheet (102) comprises a pair of side skirt portions (106) extending from two longitudinal sides of the sheet (102), to cover two longitudinal sides of the mattress, and a pair of end skirt portions (108) extending from two transverse sides of the sheet (102), to cover two transverse sides of the mattress. A set of corner pieces (110) are stitched between the adjacent side skirt portions (106) and the end skirt portions (108-1, 108-2). The corner pieces (110) have a concave curved hypotenuse side (112).

14 Claims, 4 Drawing Sheets

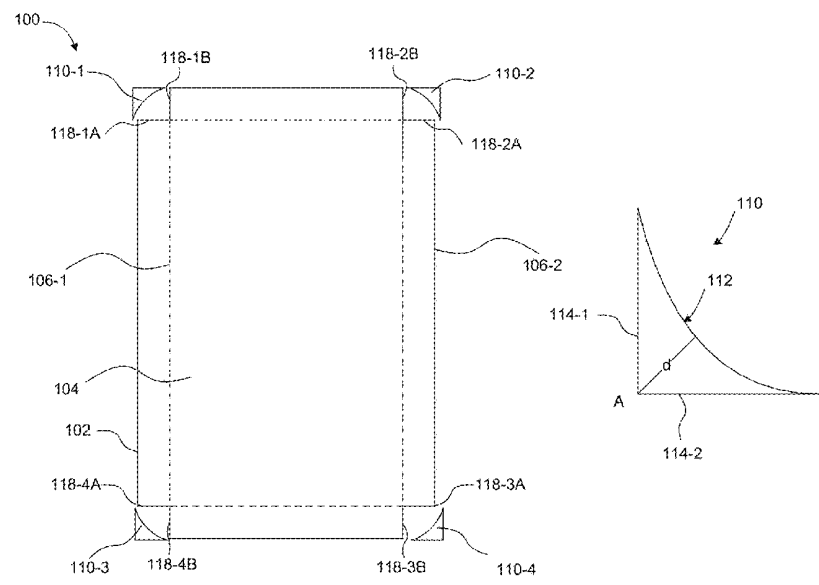

(56)

References Cited

U.S. PATENT DOCUMENTS

9,259,107	B2 *	2/2016	Lilienthal	A47G 9/02
9,510,698	B1 *	12/2016	Krotova	A47G 9/02
10,251,498	B1 *	4/2019	Feldman	A47G 9/0246
2002/0148047	A1 *	10/2002	Corzani	A47C 31/105 5/699
2004/0040090	A1 *	3/2004	Wootten	A47G 9/0246 5/497
2004/0163174	A1 *	8/2004	Treece	A47C 27/002 5/500
2007/0056100	A1 *	3/2007	Stewart	A47G 9/0246 5/497
2008/0078029	A1 *	4/2008	Seago	A47G 9/0246 5/497
2012/0054962	A1 *	3/2012	Agarwall	A47G 9/0246 5/497
2014/0109315	A1 *	4/2014	Lilienthal	A47G 9/0246 5/497
2014/0317845	A1 *	10/2014	Smith	A47G 9/0246 5/482

* cited by examiner

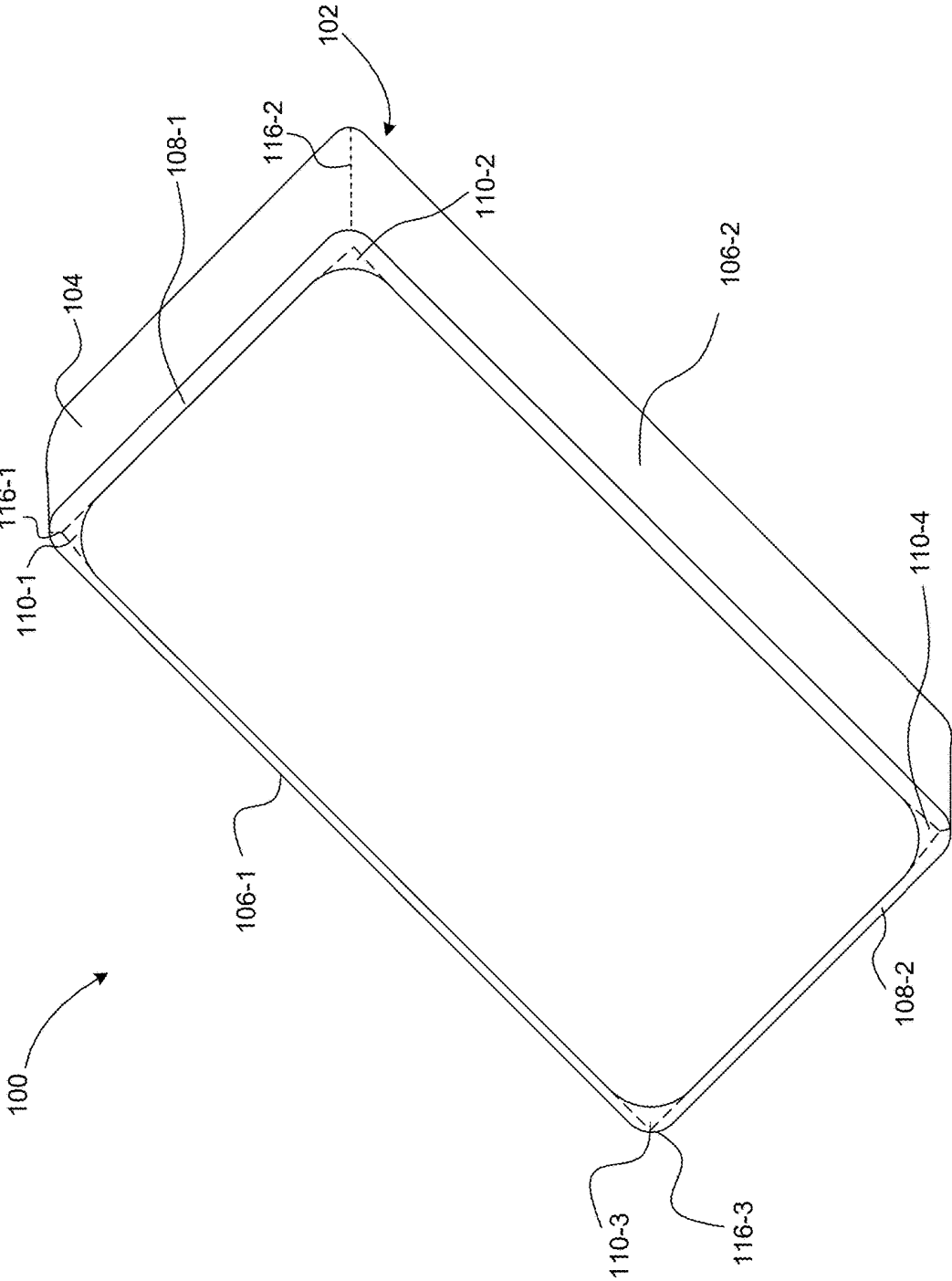

FIG. 1A

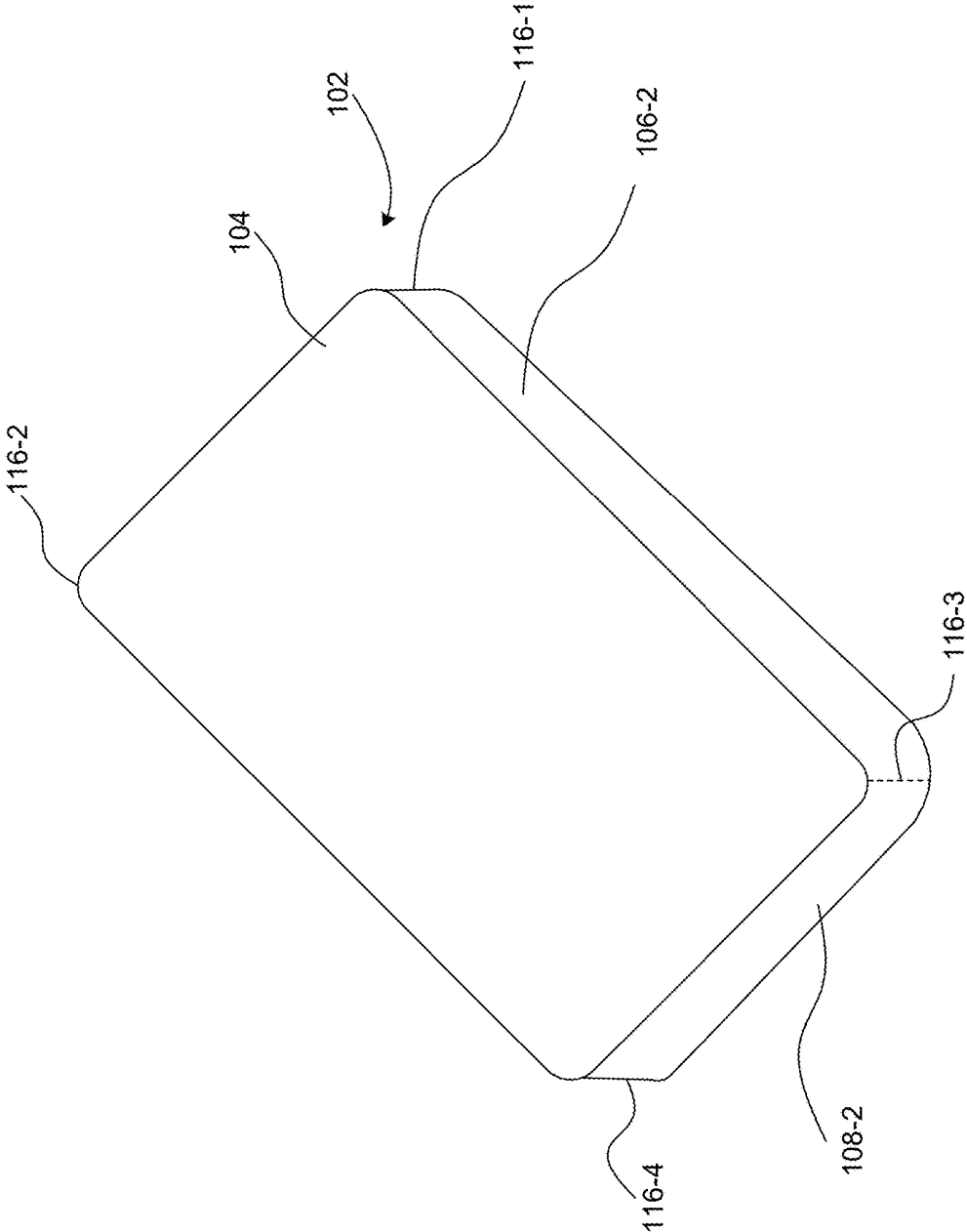

FIG. 1B

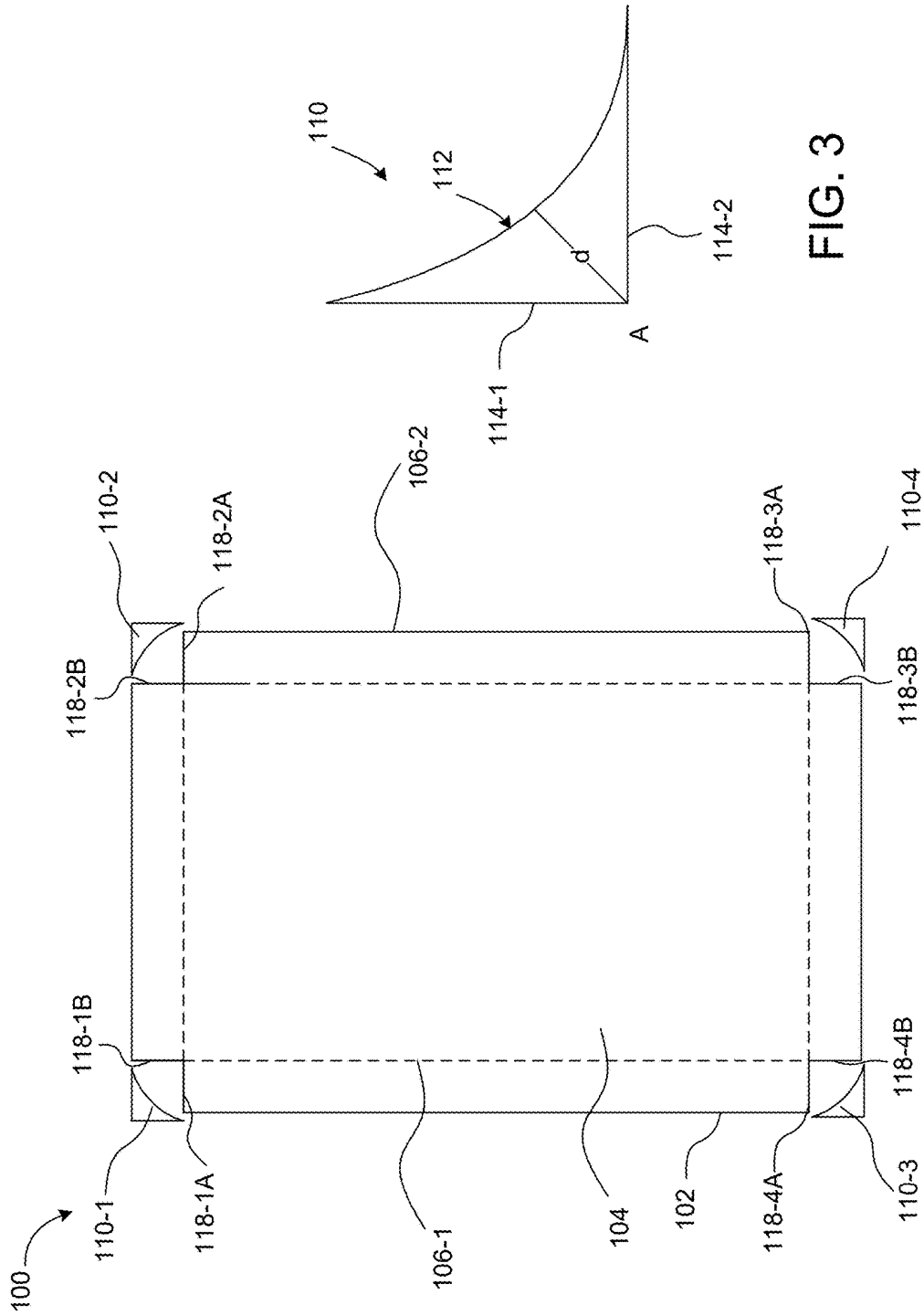

FIG. 2

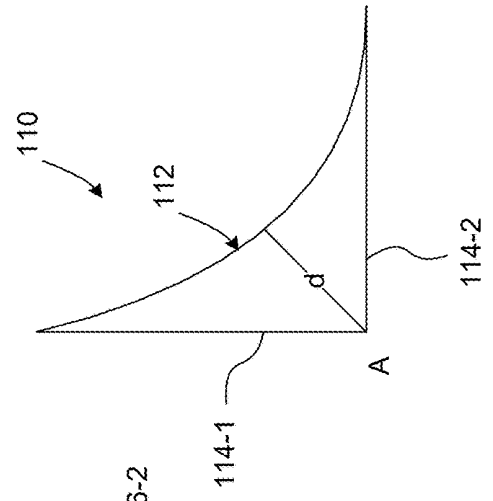

FIG. 3

FIG. 2

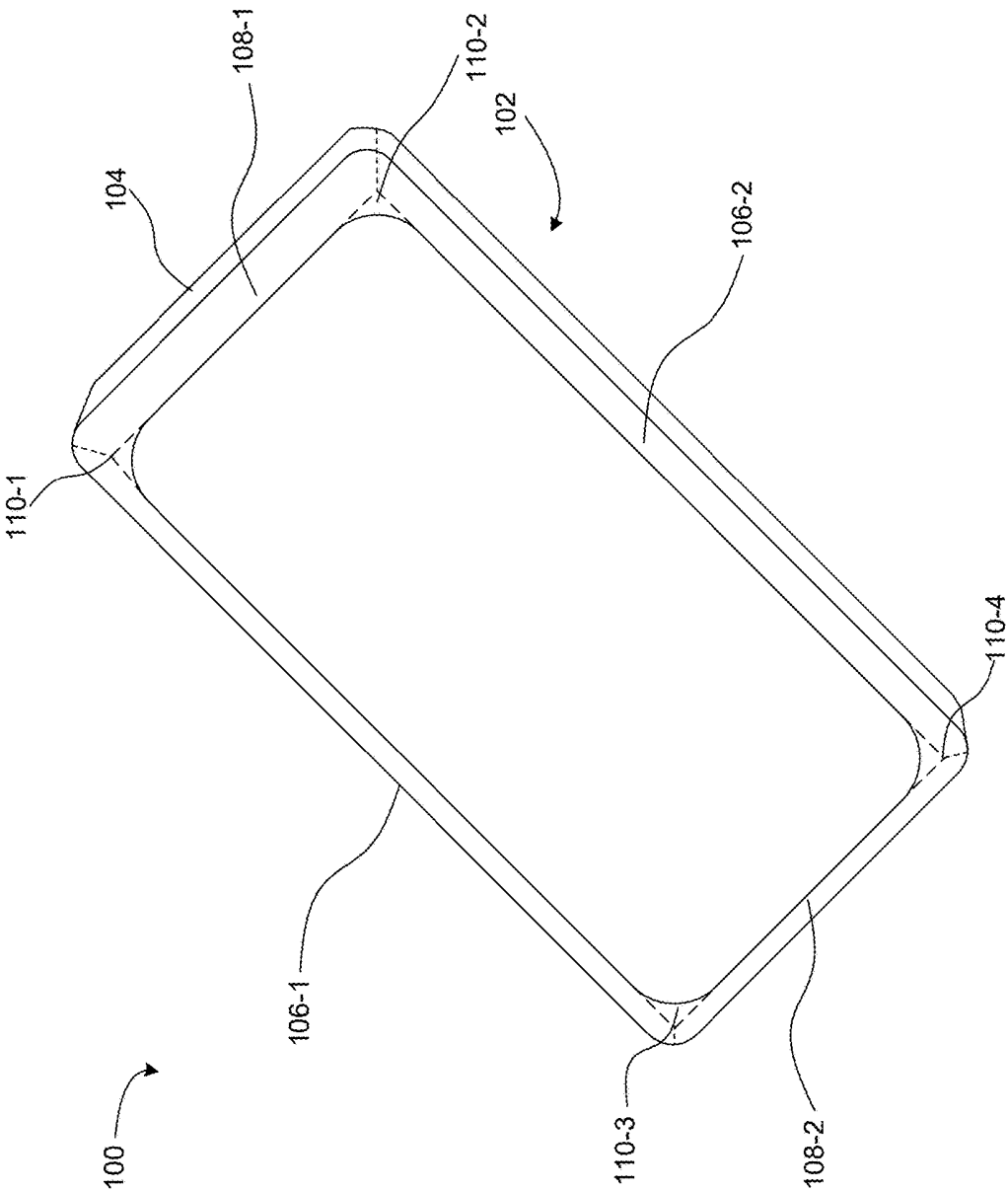

FIG. 4

MATTRESS COVER**CROSS-REFERENCE TO RELATED APPLICATIONS**

This application claims priority pursuant to 35 U.S.C. 119 (a) to Indian patent application Ser. No. 202421042159, filed May 30, 2024, which application is incorporated herein by reference in its entirety.

TECHNICAL FIELD

The present disclosure relates to the field of mattress covers. In particular, the present disclosure pertains to a mattress cover for a mattress that fits a mattress covering the sides, ends, and top of the mattress neatly and snugly and prevents the mattress cover from being easily dislodged.

BACKGROUND

Background description includes information that may be useful in understanding the present invention. It is not an admission that any of the information provided herein is prior art or relevant to the presently claimed invention, or that any publication specifically or implicitly referenced is prior art.

A mattress cover is a protective bedding item that encases or fits over a mattress, shielding the mattress from stains, spills, dust mites, and allergens. The mattress cover can be typically made of materials such as but not limited to cotton, polyester, or vinyl and can be quilted for comfort or waterproof for added protection. Using the mattress cover can prolong the life of the mattress by shielding it from damage and keeping it clean. Further, the mattress cover can also be an essential component for maintaining a hygienic sleeping environment, especially for those with allergies or asthma.

Existing mattress covers can have proper fitting issues. The existing mattress cover may shift or bunch-up during use, due to poor fitting, leading to discomfort to users and can potentially compromise the protection it offers. Further, the existing mattress covers may not be versatile enough to accommodate mattresses of different sizes or configurations. Furthermore, some of the existing mattress covers may not stretch or adjust enough to accommodate larger or smaller mattresses.

Efforts have been made in the past to improve features and design of the mattress cover to facilitate better comfort to the users. For instance, patent document WO2008/042082A2 describes a cover assembly for a mattress that includes a first cover and a second cover. The first cover includes a top panel a bottom panel, and a continuous side panel collectively defining a cavity for enclosing the mattress. The second cover includes a top surface and a bottom surface, and is positioned over and dimensionally-sized to cover at least the top panel of the first cover. A fastener connects the second cover to the first cover along the perimeter of the second cover.

However, the mattress cover disclosed in the referred document may be inefficient, due to need of extra second cover to cover the mattress. Further the referred document describes one or more zippers that extend around the perimeter of the second cover, to close the first cover and the second cover. However, frequent use and improper handling can lead to zipper damage or breakage. Further, dirt, debris, or spills may accumulate around the zipper area, requiring extra care and attention during cleaning to ensure thorough sanitation and hygiene. Furthermore, the referred mattress

cover cannot be easily fitted to different sizes, and must be tailor made and specifically designed for each mattress in accordance with their size, shape, or features.

There is, therefore, a need to overcome the above-mentioned drawbacks, shortcomings, and limitations associated with the existing mattress cover, by providing a mattress cover for a mattress that can neatly and snugly cover the sides, ends, and top of the mattress and prevents the mattress cover from being dislodged from the mattress.

OBJECTS OF THE INVENTION

A general objective of the present disclosure is to provide a simple and cost-effective mattress cover for a mattress which can overcome above-mentioned limitations of the existing mattress cover.

An objective of the present disclosure is to provide a mattress cover that can allow neatly and snugly cover the sides, ends, and top of the mattress.

An objective of the present disclosure is to provide a mattress cover that can be neatly and snugly fitted to a mattress with minimal efforts.

An objective of the present disclosure is to provide a mattress cover that can prevent the mattress cover from being easily dislodged, such as during normal use.

Another objective of the present disclosure is to provide a mattress that can facilitate a tight and secure fit, thereby preventing the cover from shifting or bunching up during use.

Yet another objective of the present disclosure is to provide a mattress cover with a neat and tidy finish that can complement a bedding ensemble, thus enhancing aesthetic appeal of a bed.

Still another objective of the present disclosure is to provide a mattress cover that can fit mattresses of different thicknesses.

SUMMARY

Aspects of the present disclosure relate generally to the field of mattress covers. In particular, the present disclosure pertains to a mattress cover for a mattress that can allow neatly and snugly cover the sides, ends, and top of the mattress and prevent the mattress cover from being pulled-out from corners.

According to an aspect, the present disclosure elaborates upon a mattress cover for a mattress. The cover comprises a sheet configured to at least partially enclose the mattress. The sheet comprises an upper portion to cover a top side of the mattress. Further, the sheet comprises a pair of side skirt portions extending from two longitudinal sides of the sheet and configured to cover two longitudinal sides of the mattress. Furthermore, the sheet comprises a pair of end skirt portions extending from two transverse sides of the sheet. The pair of end skirt portions are configured to cover two transverse sides of the mattress, where adjacent side skirt portions and the end skirt portions are sewed to one other such that the sewed joints fit four corners of the mattress.

In addition, the cover comprises a set of corner pieces stitched between the adjacent side skirt portions and the end skirt portions. The set of corner pieces are stitched such that the corner pieces are parallel to the upper portion and rest, when the cover is fitted to the mattress, against a bottom side of the mattress. Furthermore, the corner pieces have a concave curved hypotenuse side.

In an aspect, the curved hypotenuse may include any of a circular, a hyperbola and a parabola shape.

In an aspect, the pair of side skirt portions and the pair of end skirt portions may be integral to the upper portion.

In an aspect, the upper portion, the pair of side skirt portions and the pair of end skirt portions may be formed by cutting square shaped pieces from four corners of a rectangular or square shaped sheet material.

In an aspect, the mattress cover may be a protective cover with the sheet having an exterior surface and an interior surface. The exterior surface may be made of hydrophilic fabric. Further, the interior surface may be made of hydrophobic fabric to resist penetration of fluid towards the surface of the mattress.

In an aspect, the mattress cover may include one or more elastic strips attached around a bottom periphery defined by the hypotenuse sides of the set corner pieces, free sides of the pair of side skirt portions and free sides of the pair of end skirt portions. The one or more elastic strips can allow the bottom periphery of the mattress cover to stretch and contract.

In an aspect, a length (l) of sides of the corner pieces may be 0.05 to 0.20 times a length of the mattress.

In an aspect, a distance of the hypotenuse side from a corresponding apex of the corner pieces may be less than a thickness of the mattress.

In an aspect, a width of the side skirt portions and the end skirt portions may be more than a thickness of the mattress such that a portion of the side skirt portions and the end skirt portions may fold over the bottom side of the mattress.

In an aspect, the hydrophobic material for the interior surface of the sheet may be selected from a group consisting of: polypropylene, polyester, nylon, acrylic, and mod acrylic.

In an aspect, the hydrophilic material for the exterior surface of the sheet may be selected from a group consisting of: cotton, wool, linen, and silk.

In an aspect, the mattress cover may be a bed sheet made of a cotton or synthetic, or a blended material.

Various objects, features, aspects, and advantages of the inventive subject matter will become more apparent from the following detailed description of preferred embodiments, along with the accompanying drawing figures in which like numerals represent like components.

BRIEF DESCRIPTION OF THE DRAWINGS

The accompanying drawings are included to provide a further understanding of the present disclosure, and are incorporated in and constitute a part of this specification. The drawings illustrate exemplary embodiments of the present disclosure and, together with the description, serve to explain the principles of the present disclosure.

FIG. 1A illustrates an exemplary view of a proposed mattress cover showing the side skirt portions, end skirt portions and corner pieces, in accordance with an embodiment of the present disclosure;

FIG. 1B illustrates an exemplary top view of the proposed mattress cover of FIG. 1A, in accordance with an embodiment of the present disclosure;

FIG. 2 illustrates an exemplary exploded view of the proposed mattress cover of FIG. 1A, showing a piece of sheet material cut to manufacture the proposed mattress cover, and corner pieces, in accordance with an embodiment of the present disclosure;

FIG. 3 illustrates an exemplary view of a corner piece with a curved hypotenuse side, in accordance with an embodiment of the present disclosure; and,

FIG. 4 illustrates an exemplary view of a proposed mattress cover fitted over a thicker mattress showing that corner pieces of the mattress cover are covering the bottom corners of the thick mattress, in accordance with an embodiment of the present disclosure.

DETAILED DESCRIPTION

The following is a detailed description of embodiments of the disclosure depicted in the accompanying drawings. The embodiments are in such details as to clearly communicate the disclosure. However, the amount of detail offered is not intended to limit the anticipated variations of embodiments; on the contrary, the intention is to cover all modifications, equivalents, and alternatives falling within the spirit and scope of the present disclosure as defined by the appended claims.

Embodiments explained herein relate to the field of mattress covers. In particular, the present disclosure pertains to a mattress cover for a mattress that can allow neatly and snugly cover the sides, ends, and top of the mattress and prevent the mattress cover from being pulled-out from corners.

In an aspect, the present disclosure provides a mattress cover for a mattress, also known as a fitted mattress cover. The cover includes a sheet configured to at least partially enclose the mattress. The sheet comprises an upper portion to cover a top side of the mattress. Further, the sheet includes a pair of side skirt portions extending from two longitudinal sides of the sheet and configured to cover two longitudinal sides of the mattress. Furthermore, the sheet includes a pair of end skirt portions extending from two laterally disposed end sides/transverse sides of the sheet. The pair of end skirt portions are configured to cover two transverse sides of the mattress, where adjacent side skirt portions and the end skirt portions are sewed to one other such that the sewed joints fit four corners of the mattress.

In addition, the cover includes a set of corner pieces stitched between the adjacent side skirt portions and the end skirt portions. The set of corner pieces are stitched such that the corner pieces are parallel to the upper portion, and rest, when the cover is fitted to the mattress, against a bottom side of the mattress. Furthermore, the corner pieces have a concave curved hypotenuse side.

Referring to FIGS. 1A, 1B, 2 and 3, mattress cover **100** for a mattress includes sheet **102** configured to at least partially enclose the mattress. Mattress cover **100** can be a bed sheet that can be made of but not limited to a cotton or synthetic, or a blended material. As shown in FIG. 2, sheet **102** includes upper portion **104** to cover a top side of the mattress. Sheet **102** can have an exterior surface and an interior surface. When mattress cover **100** is a protective cover, the exterior surface of sheet **102** can be made of hydrophilic fabric, and the interior surface can be made of hydrophobic fabric to resist penetration of fluid towards the surface of the mattress. In an embodiment, the hydrophobic material for the interior surface of sheet **102** can be selected but not limited to from a group consisting of: polypropylene, polyester, nylon, acrylic, and mod acrylic. Further, the hydrophilic material for the exterior surface of sheet **102** can be selected from but not limited to a group consisting of: cotton, wool, linen, and silk. In different applications, sheet **102** can be entirely made of a single material, such as, but not limited to, cotton, wool, linen, and silk, without any protective inner surface.

In an embodiment, sheet **102** includes a pair of side skirt portions, such as side skirt portions **106-1**, **106-2** (collec-

tively referred to as side skirt portions **106**, herein) extending from two longitudinal sides of sheet **102**. Side skirt portions **106** may be configured to cover two longitudinal sides of the mattress. Further, sheet **102** includes a pair of end skirt portions **108-1**, **108-2** (collectively referred to as end skirt portions **108**, herein) extending from two laterally disposed end sides/transverse sides of sheet **102**. The pair of end skirt portions **108** can be configured to cover two transverse sides of the mattress.

As evident from FIG. 2, the side skirt portions **106** and the end skirt portions **108** can be formed by cutting square pieces from four corners of the sheet **102**. The cut corners can result in formation of corner edges, such as the corner edges **118-1A** and **118-1B** for the top left corner, the corner edges **118-2A** and **118-2B** for the top right corner, the corner edges **118-3A** and **118-3B** for the bottom right corner, and the corner edges **118-4A** and **118-4B** for the bottom left corner (collectively referred to as corner edges **118**, hereinafter).

In an embodiment, pairs to corner edges **118**, such as **118-1A** and **118-1B**, of the four corners, i.e., corner edges **118**, of adjacent side skirt portions **106** and end skirt portions **108** can be sewed to one other such that the sewed joints, such as sewed joints **116-1**, **116-2**, **116-3** and **116-4** shown in Figures, 1A and 1B, fit four corners of the mattress.

In an embodiment, while FIG. 2 shows the side skirt portions **106** and end skirt portions **108** formed by cutting off corners of sheet **102** thereby making side skirt portions **106** and end skirt portions **108** integral to the upper portion **104**, i.e., the five portions fabricated from a single sheet of material, it is possible to fabricate sheet **102** by sewing side skirt portions **106** and the end skirt portions **108** cut from a different piece of fabric and sewing the separately cut side skirt portions **106** and end skirt portions **108** to upper portion **104**. This gives flexibility in having upper portion **104** and skirt portions **106** & **108** of different colors, texture, material, etc.

In an embodiment, a width of side skirt portions **106** and end skirt portions **108** can be sized to be at least equal to a thickest of the mattresses with which the proposed cover **100** is to be used, such that when cover **100** is used with a mattress having a lesser thickness, a portion of side skirt portions **106** and end skirt portions **108** gets folded inwards to be positioned against the bottom side of the mattress, as shown in FIG. 1A. In an embodiment, the width of side skirt portions **106** and end skirt portions **108** can be more than the thickness of the thickest of the mattress with which cover **100** is to be used, such that a portion of side skirt portions **106** and end skirt portions **108** is always folded inwards to rest against the bottom side of the mattress.

In an embodiment, mattress cover includes a set of corner pieces, such as corner pieces **110-1**, **110-2**, **110-3**, **110-4** (individually/collectively referred to as corner piece/corner pieces **110**, herein) stitched between adjacent side skirt portions **106** and end skirt portions **108**. Corner pieces **110** can be parallel to the upper portion **104** and rest, when the cover **100** is fitted to the mattress, and rest against the bottom side of the mattress. In an embodiment, as shown in FIG. 3, corner pieces **110** can be generally of an isosceles triangle with a pair of perpendicular sides of equal length, such as perpendicular sides **114-1** and **114-2** (collectively referred to as sides **114**, herein), and a concave curved hypotenuse side **112**. Curved hypotenuse **112** can include any one of, but not limited to: a circular shape, a hyperbola shape, and a parabola shape. Further, a distance (d) of hypotenuse side **112** from a corresponding apex of corner piece **110** can be less than a thickness of the mattress, such as the thickest

mattress. Furthermore, a length of sides **114** of corner pieces **110** can be 15.0 cm to 38.0 cm (6 inches to 15 inches).

In another embodiment, the length of sides **114** of the corner pieces **110** can be linked to size of the mattress, such as the length of sides **114** can be 0.05 to 20 times the length of the mattress/upper portion **104** of cover **100**. The proposed size of the corner pieces shall ensure that cover **100** remains difficult to get dislodged from the mattress irrespective of the thickness of the mattress (as shown in FIGS. 1A and 1C), and yet does not pose difficulty in taking off cover **100** from the mattress.

In yet another embodiment, the lengths of two sides **114** of corner pieces **110** can be unequal, i.e., corner pieces **110** may not be an isosceles triangle, with side **114** fixed to transverse sides of sheet **102** being smaller than the side fixed to the longitudinal side of sheet **102**, linked to the lengths of the respective side.

In an advantageous aspect of the present disclosure, the corner piece with curved hypotenuse side, which has a parabolic or hyperbolic shape, allows size of sides **114** to be increased without proportionate increase in the distance (d) of hypotenuse side **112** from a corresponding apex of corner piece **110**, which if increased, shall make removal of cover **100** from the mattress difficult. Increase in length of sides **114** prevents unintended dislodging of the cover from underneath the mattress when the overlap of skirt portions **106**, **108** with the bottom of the mattress is low. In another aspect, on account of the permissible reduced overlap of sheet skirt portions **106**, **108** with the bottom of the mattress, sheet **102** can be fabricated with reduced size of fabric.

In an embodiment, one or more elastic strips can be attached around a bottom periphery defined by the hypotenuse sides **112** of the set corner pieces **110**, free sides of the side skirt portions **106** and free sides of end skirt portions **108**. The one or more elastic strips can allow the bottom periphery of mattress cover **100** to stretch and contract. The one or more elastic strips can be elastic bands made from a series of rubber. The rubber can be selected either from a natural rubber or a synthetic rubber. In an embodiment, the one or more elastic strips can be made from combination of materials such as but not limited to rubber, nylon, polyester and the like.

The one or more elastic strips help to pull skirt portions **106**, **108** inwards, which can be especially advantageous when cover is used with a mattress having lower thickness than cover **100** is designed for. FIG. 4 shows a bottom side of the mattress fitted with cover **100**, where the mattress is of lower thickness than cover **100** is designed for, showing excess skirt portions **106**, **108** pulled inward by the elastic strips to keep the cover fold/wrinkle free on the top and sides of the mattress.

Thus, the present disclosure overcomes the drawbacks, shortcomings, and limitations associated with the existing mattress cover, by providing a simple, cost-effective mattress cover **100**, having advantageous features. The advantageous features include corner pieces **110** have a concave curved hypotenuse side **112**, to facilitate a tight and secure fit, thereby preventing the cover from shifting or bunching up during sleep. The proposed mattress cover **100** can fit over a different range of mattress sizes. Further, the proposed flexible mattress cover **100** fits over the mattress of varying thickness range.

While the foregoing describes various embodiments of the invention, other and further embodiments of the invention may be devised without departing from the basic scope thereof. The scope of the invention is determined by the claims that follow. The invention is not limited to the

described embodiments, versions or examples, which are included to enable a person having ordinary skill in the art to make and use the invention when combined with information and knowledge available to the person having ordinary skill in the art.

Advantages of the Invention

The present invention provides a simple and cost-effective mattress cover which can overcome limitations of the existing mattress cover.

The present invention provides a mattress cover that allows neatly and snugly cover the sides, ends, and top of the mattress.

The present invention provides a mattress cover that can be neatly and snugly fitted to a mattress with minimal efforts.

The present invention provides a mattress cover that can prevent the mattress cover from being easily dislodged, such as during normal use.

The present invention provides a mattress that can facilitate a tight and secure fit, thereby preventing the cover from shifting or bunching up during use.

The present invention provides a mattress cover with a neat and tidy finish that can complement a bedding ensemble, thus enhancing aesthetic appeal of a bed.

The present invention provides a mattress cover that can fit mattresses of different thicknesses.

I claim:

1. A mattress cover (100), comprising:
 - a sheet (102) configured to at least partially enclose the mattress, the sheet (102) comprising an upper portion (104) to cover a top side of the mattress, a pair of side skirt portions (106) extending from two longitudinal sides of the sheet (102) and configured to cover two longitudinal sides of the mattress, and a pair of end skirt portions (108) extending from two transverse sides of the sheet (102) and configured to cover two transverse sides of the mattress, wherein adjacent side skirt portions (106) and the end skirt portions (108) are sewed to one other such that the sewed joints fit four corners of the mattress; and
 - a set of corner pieces (110) stitched between the adjacent side skirt portions (106) and the end skirt portions (108) such that the set of corner pieces (110) are parallel to the upper portion (104) and rest, when the cover is fitted to the mattress, against a bottom side of the mattress; wherein the set of corner pieces (110) are of a triangular shape with two perpendicular sides (114) and a concave curved hypotenuse side (112).
2. The mattress cover (100) as claimed in claim 1, wherein the curved hypotenuse side (112) comprises any of a circular, a hyperbola and a parabola shape.

3. The mattress cover (100) as claimed in claim 1, wherein the pair of side skirt portions (106) and the pair of end skirt portions (108) are integral to the upper portion.

4. The mattress cover (100) as claimed in claim 1, wherein the upper portion (104), the pair of side skirt portions (106) and the pair of end skirt portions (108) are formed by cutting square shaped pieces from four corners of a rectangular or square shaped sheet material.

5. The mattress cover (100) as claimed in claim 1, wherein the mattress cover (100) is a protective cover with the sheet (102) having an exterior surface and an interior surface, wherein the exterior surface is made of hydrophilic fabric, and the interior surface is made of hydrophobic fabric to resist penetration of fluid towards the surface of the mattress.

6. The mattress cover (100) as claimed in claim 1, comprising one or more elastic strips attached around a bottom periphery defined by the hypotenuse sides (112) of the set of corner pieces (110), free sides of the pair of side skirt portions (106) and free sides of the pair of end skirt portions (108-1, 108-2), where the one or more elastic strips allow the bottom periphery of the mattress cover (100) to stretch and contract.

7. The mattress cover (100) as claimed in claim 1, wherein a length (l) of sides (114) of the set of corner pieces (110) is 15.0 cm to 38.0 cm (6 inches to 15 inches).

8. The mattress cover (100) as claimed in claim 1, wherein a length (l) of sides (114) of the set of corner pieces (110) is 0.05 to 0.20 times a length of the mattress.

9. The mattress cover (100) as claimed in claim 1, wherein the corner pieces (110) have sides (114) of unequal length with the side (114) fixed to longitudinal side of the sheet (102) being bigger than the side (114) to transverse side of the sheet (102).

10. The mattress cover (100) as claimed in claim 1, wherein a distance (d) of the hypotenuse side (112) from a corresponding apex of the set of corner pieces (110) is less than a thickness of the mattress.

11. The mattress cover (100) as claimed in claim 1, wherein a width of the side skirt portions (106) and the end skirt portions (108) is more than a thickness of the mattress such that a portion of the side skirt portions (106) and the end skirt portions (108) folds over the bottom side of the mattress.

12. The mattress cover (100) as claimed in claim 5, wherein the hydrophobic material for the interior surface of the sheet (102) is selected from a group consisting of: polypropylene, polyester, nylon, acrylic, and mod acrylic.

13. The mattress cover (100) as claimed in claim 5, wherein the hydrophilic material for the exterior surface of the sheet (102) is selected from a group consisting of: cotton, wool, linen, and silk.

14. The mattress cover (100) as claimed in claim 1, wherein the mattress cover (100) is a bed sheet made of a cotton or synthetic, or a blended material.

* * * * *