



US012661538B2

(12) **United States Patent**  
**Carroccia et al.**

(10) **Patent No.:** **US 12,661,538 B2**  
(45) **Date of Patent:** **\*Jun. 23, 2026**

(54) **FORCE DAMPER**

(56) **References Cited**

(71) Applicant: **On Top Safety Equipment, LLC**,  
Cheektowaga, NY (US)

U.S. PATENT DOCUMENTS

(72) Inventors: **John J. Carroccia**, Orchard Park, NY  
(US); **Jeffrey L. Murray**, Hamburg,  
NY (US)

2,373,508 A \* 4/1945 Snyder ..... F16F 7/095  
188/129  
2,404,666 A \* 7/1946 Snyder ..... F16F 7/09  
267/213

(Continued)

(73) Assignee: **ON TOP SAFETY EQUIPMENT,  
LLC**, Cheektowaga, NY (US)

FOREIGN PATENT DOCUMENTS

(\* ) Notice: Subject to any disclaimer, the term of this  
patent is extended or adjusted under 35  
U.S.C. 154(b) by 1043 days.

DE 202008002704 5/2008  
DE 202008002704 U1 \* 6/2008 ..... A62B 35/04

OTHER PUBLICATIONS

This patent is subject to a terminal dis-  
claimer.

Model No. 1340101 PROT M Stretch Shock Absorbing Lanyard  
manufactured by Protecta®, 3M Protecta Catalog Rev E, Fall  
2016—previously submitted in parent application.

(21) Appl. No.: **17/305,690**

*Primary Examiner* — Daniel P Cahn

(22) Filed: **Jul. 13, 2021**

*Assistant Examiner* — Shiref M Mekhaeil

(65) **Prior Publication Data**

(74) *Attorney, Agent, or Firm* — Simpson & Simpson,  
PLLC

US 2021/0339064 A1 Nov. 4, 2021

**Related U.S. Application Data**

(57) **ABSTRACT**

(60) Division of application No. 16/784,939, filed on Feb.  
7, 2020, now Pat. No. 11,090,518, which is a  
(Continued)

A force damper arranged to progressively arrest a first force  
imparted by an object moving in a first direction is disclosed.  
The force damper includes a housing enclosure having a first  
housing end and a second housing end. The first housing end  
includes a first connection point, and the second housing end  
includes an opening. A driving member is disposed within  
the housing enclosure and includes a first shaft end, a second  
shaft end, and a shaft therebetween. The first shaft end  
includes a stop and the second shaft end includes a second  
connection point. A compressible member is disposed within  
the housing enclosure between the stop and the opening. The  
compressible member is formed from a material that at least  
partially undergoes plastic deformation when the first force  
is arrested and imparts a second force on the stop toward first  
housing end.

(51) **Int. Cl.**

**A62B 35/04** (2006.01)  
**A62B 35/00** (2006.01)  
**F16F 13/00** (2006.01)

(52) **U.S. Cl.**

CPC ..... **A62B 35/04** (2013.01); **A62B 35/0068**  
(2013.01); **F16F 13/005** (2013.01);  
(Continued)

(58) **Field of Classification Search**

CPC ..... F16F 13/005; F16F 13/04; F16F 7/003;  
F16F 7/12; F16F 2224/0208;  
(Continued)

**7 Claims, 21 Drawing Sheets**

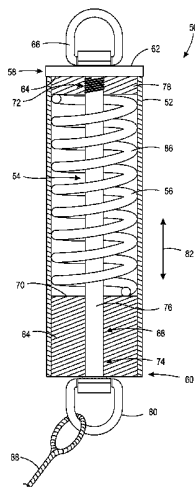

<b>Related U.S. Application Data</b>					
	continuation-in-part of application No. 16/113,618, filed on Aug. 27, 2018.	5,588,511	A *	12/1996	Kallenbach ..... F16L 3/20 188/134
		5,799,760	A *	9/1998	Small ..... A62B 35/04 267/155
		6,471,198	B2 *	10/2002	Herbst ..... F16F 1/40 267/293
(60)	Provisional application No. 62/610,786, filed on Dec. 27, 2017.	6,485,411	B1 *	11/2002	Konstorum ..... A61B 1/00078 604/527
		6,854,574	B2 *	2/2005	Yoshida ..... B60R 19/34 293/133
(52)	<b>U.S. Cl.</b> CPC ..... F16F 2224/0208 (2013.01); F16F 2224/0225 (2013.01); F16F 2224/025 (2013.01)	7,007,350	B1 *	3/2006	Franke ..... E04G 21/3276 24/136 B
		7,579,550	B2 *	8/2009	Dayton ..... A61B 1/0055 174/108
(58)	<b>Field of Classification Search</b> CPC ..... F16F 2224/0233; F16F 2228/14; F16F 2230/0047; F16F 2232/08; F16F 2224/0225; F16F 2224/025; A62B 35/04; B60G 11/48; B60G 11/50; B60G 11/52; B60G 11/54; B60G 11/56; B60G 11/58; B60G 11/60; B60G 11/62; B60G 11/64 See application file for complete search history.	8,182,023	B2 *	5/2012	Nagwanshi ..... B60R 19/18 296/187.09
		8,608,142	B2 *	12/2013	Von Allmen ..... F16F 7/128 267/170
		8,820,493	B2 *	9/2014	Parida ..... F16F 9/303 188/374
		9,422,999	B2 *	8/2016	Hermann ..... F16F 13/1409
		10,663,110	B1 *	5/2020	Rawas ..... B33Y 50/02
		11,293,509	B2 *	4/2022	Muraguchi ..... F16F 1/127
		2002/0165532	A1 *	11/2002	Hill, III ..... A61B 18/1492 606/41
(56)	<b>References Cited</b>	2002/0177906	A1 *	11/2002	Phillips ..... A61F 2/60 623/27
	<b>U.S. PATENT DOCUMENTS</b>	2004/0145098	A1 *	7/2004	Thaler ..... F16F 1/445 267/33
		2,421,822	A *	6/1947	Wood ..... F16L 3/18 248/562
		2,678,796	A *	5/1954	Roy ..... F16F 3/10 267/152
		2,724,463	A *	11/1955	Becker ..... A47L 3/04 182/4
		3,462,137	A *	8/1969	Grube ..... B60P 7/0823 410/41
		3,610,606	A *	10/1971	Andrews ..... F16F 15/04 269/162
		3,637,174	A *	1/1972	Kuo ..... C10G 9/20 188/1.11 R
		3,862,673	A *	1/1975	Benson ..... F16F 1/3713 280/805
		4,154,140	A *	5/1979	Zeilon ..... F16B 13/025 411/16
		4,601,367	A *	7/1986	Bongers ..... B29D 28/005 293/133
		4,624,493	A *	11/1986	Hillebrand ..... B60R 19/34 267/140
		4,955,467	A *	9/1990	Kallenbach ..... F16F 7/09 188/134
		4,976,443	A *	12/1990	DeLucia ..... F42B 6/08 473/583
		5,240,232	A *	8/1993	Loziuk ..... F16L 3/2056 267/136
		5,257,680	A *	11/1993	Corcoran ..... F16F 13/04 188/290
		5,332,071	A *	7/1994	Duncan ..... E04G 21/3295 267/74
		5,358,068	A *	10/1994	Whitmer ..... E04G 21/3204 182/113
		5,458,214	A *	10/1995	Olson ..... F16F 7/00 182/18
		5,468,019	A *	11/1995	Blase ..... B60R 22/4619 297/480
		2006/0289708	A1 *	12/2006	Lin ..... B60R 11/00 248/160
		2009/0107781	A1 *	4/2009	Fritz ..... F16F 9/585 188/280
		2010/0000504	A1 *	1/2010	Trpkovski ..... F41B 5/0094 124/25.6
		2011/0114427	A1 *	5/2011	Parida ..... F16F 9/303 29/428
		2011/0227353	A1 *	9/2011	Nagwanshi ..... F16F 1/04 293/137
		2011/0233975	A1 *	9/2011	Mindel ..... B64D 11/0689 188/371
		2012/0186436	A1 *	7/2012	Parida ..... B61G 11/12 89/930
		2012/0193165	A1 *	8/2012	Vetesnik ..... F16F 7/125 188/65.1
		2012/0264523	A1 *	10/2012	Liebing ..... F16C 1/06 464/60
		2014/0332645	A1 *	11/2014	Brooks ..... A01M 31/06 248/156
		2016/0199678	A1 *	7/2016	Tsai ..... C08G 18/6674 248/636
		2016/0363186	A1 *	12/2016	McCoy ..... F16F 7/09
		2017/0128756	A1 *	5/2017	Schurian ..... A62B 35/04
		2017/0247894	A1 *	8/2017	Sargent ..... A62B 35/04
		2018/0209504	A1 *	7/2018	Kim ..... F16F 3/02
		2018/0264297	A1 *	9/2018	Poldmaa ..... F16F 7/003
		2018/0323489	A1 *	11/2018	Vermillion, Jr. .... H01Q 1/281
		2019/0176733	A1 *	6/2019	Abushawashi ..... B62D 21/157
		2019/0195310	A1	6/2019	Carroccia
		2019/0234480	A1 *	8/2019	Bu ..... F16F 15/022
		2019/0301662	A1 *	10/2019	Brooks ..... A01K 39/01
		2019/0337046	A1 *	11/2019	Sugita ..... B21F 3/06
		2020/0070870	A1 *	3/2020	Terada ..... B62D 3/126
		2021/0190164	A1 *	6/2021	Muraguchi ..... F16F 1/127

\* cited by examiner

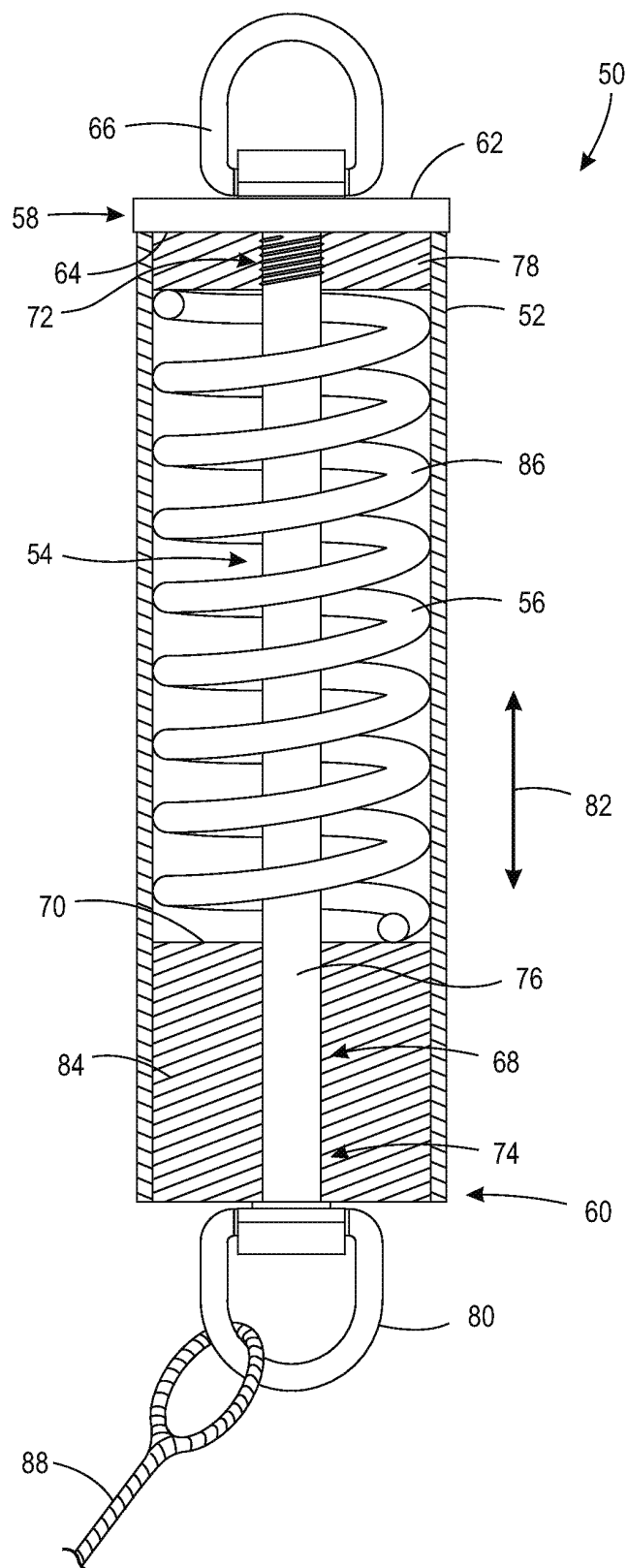

FIG. 1

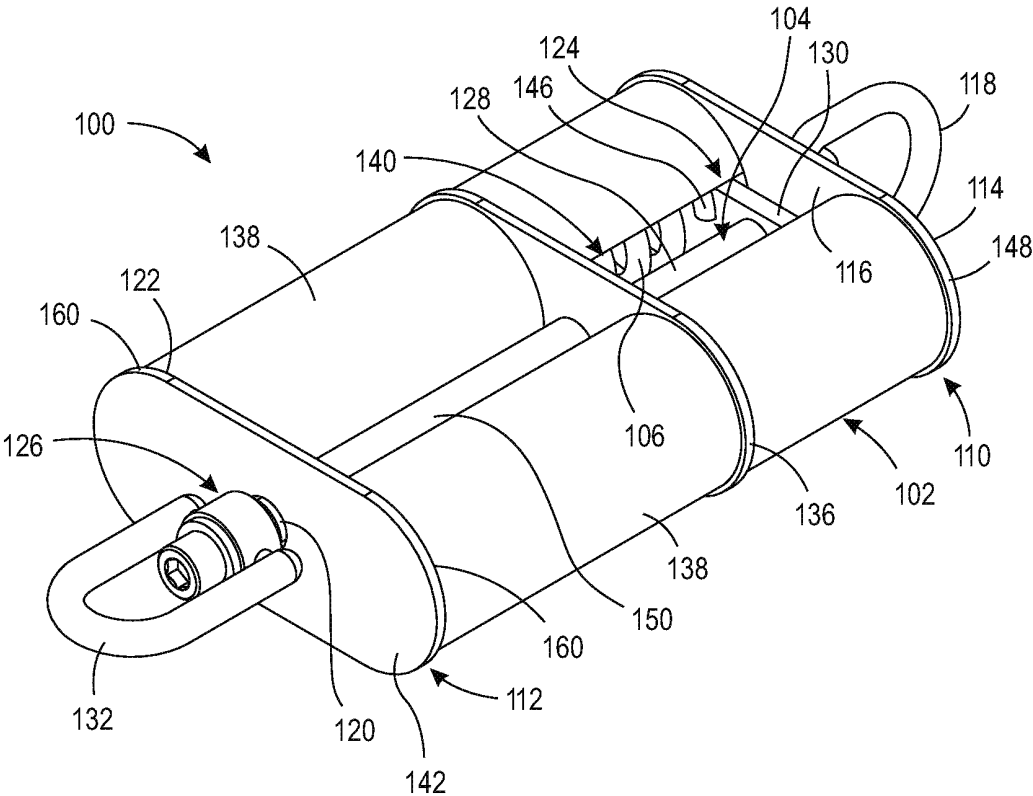

FIG. 2

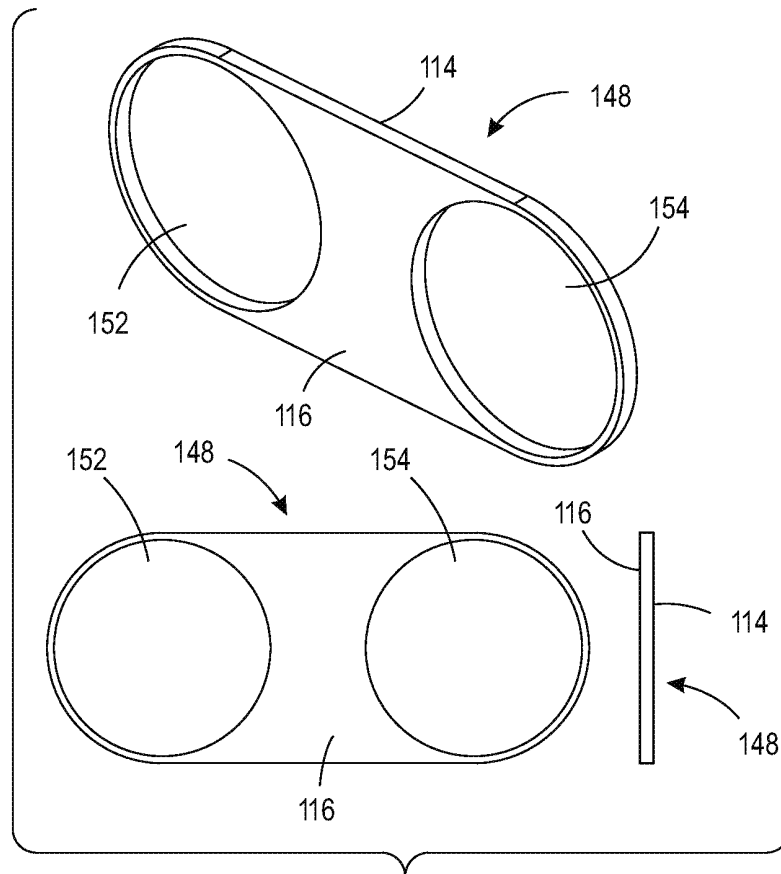

FIG. 3

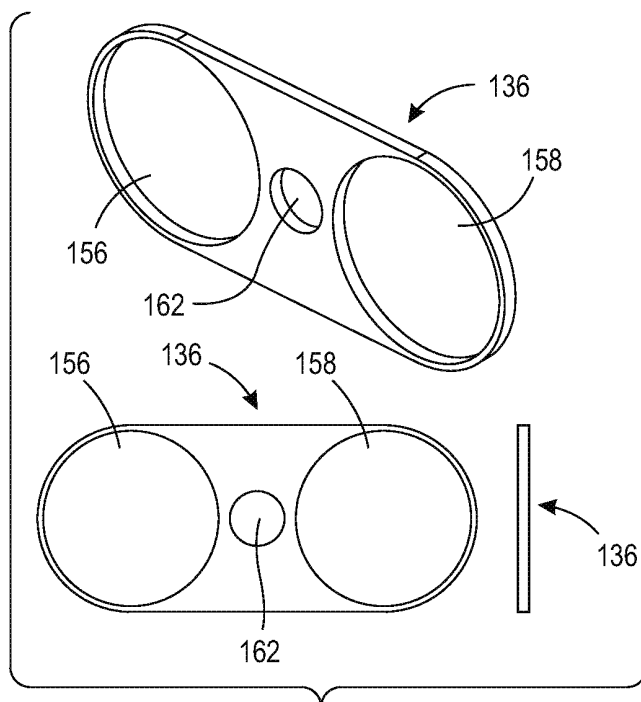

FIG. 4

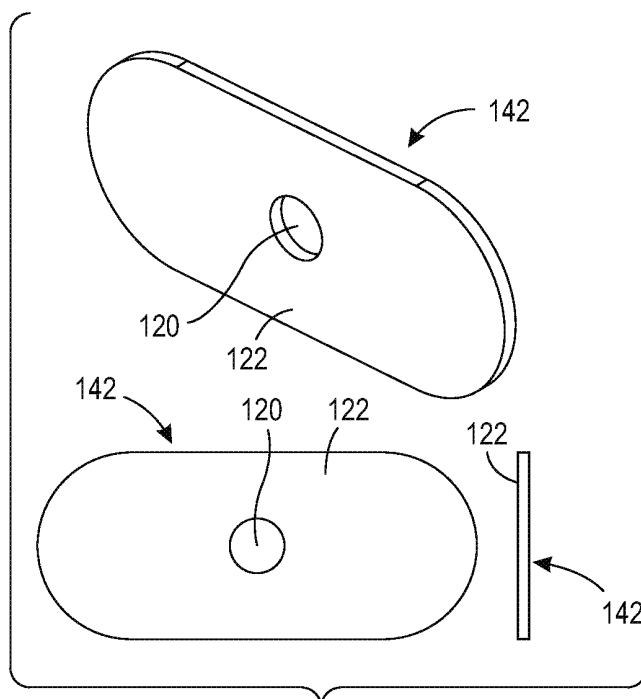

FIG. 5

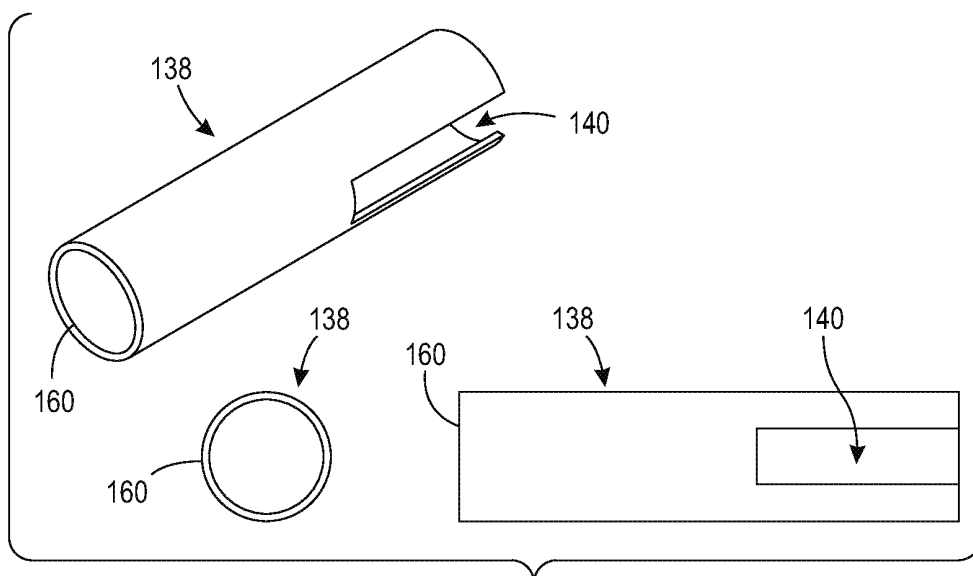

FIG. 6

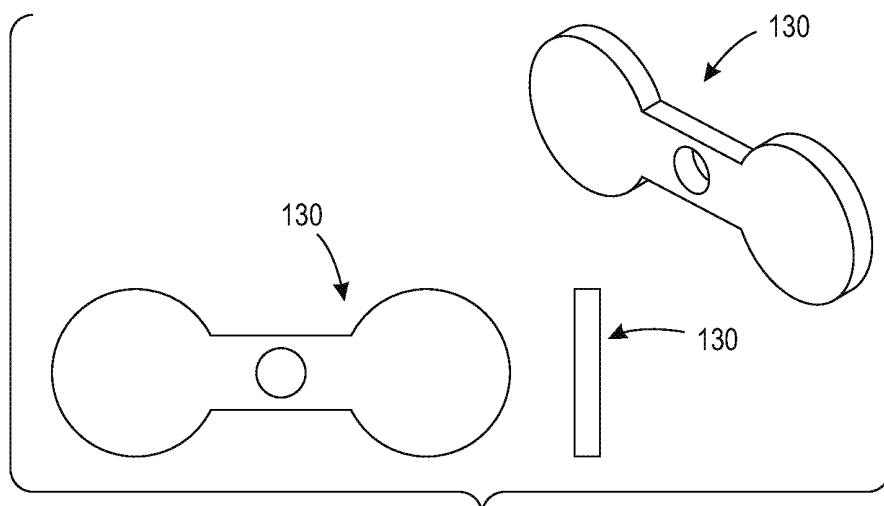

FIG. 7

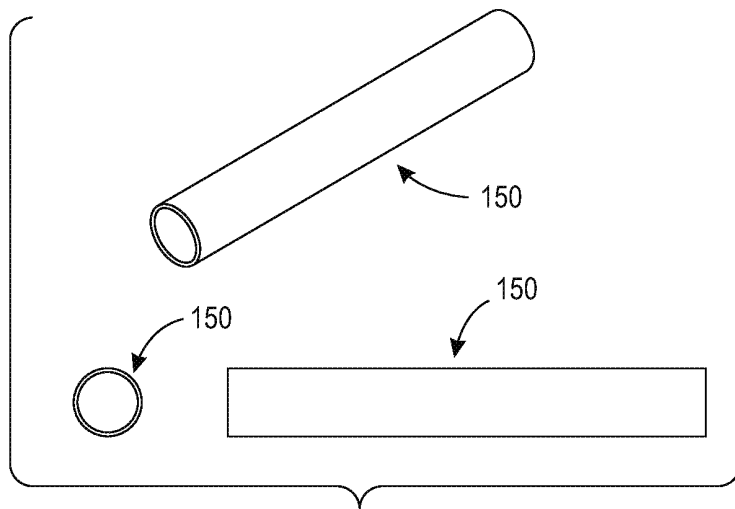

FIG. 8

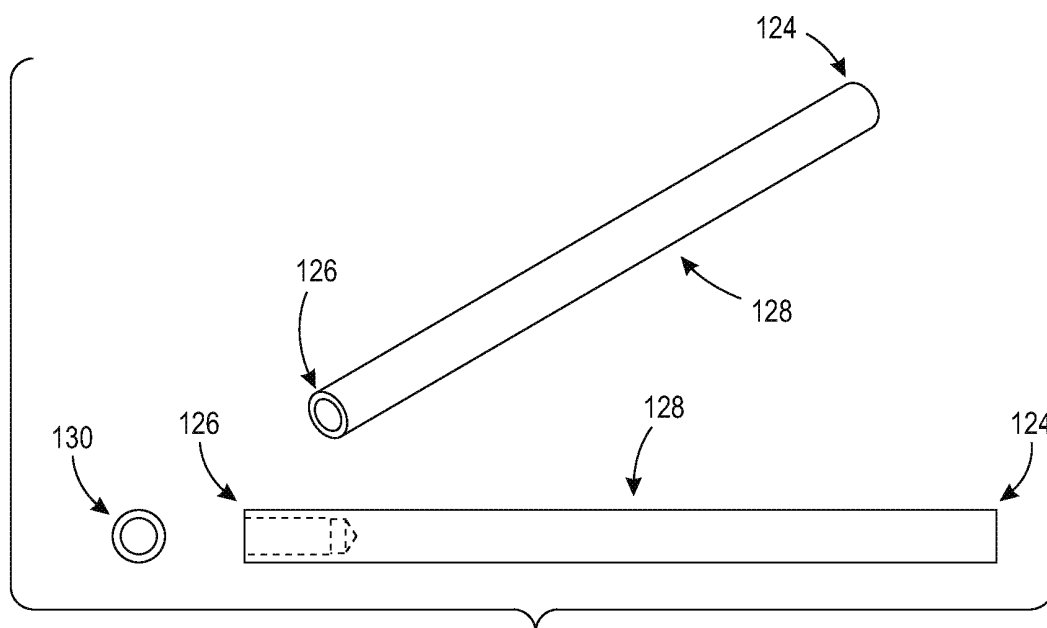

FIG. 9

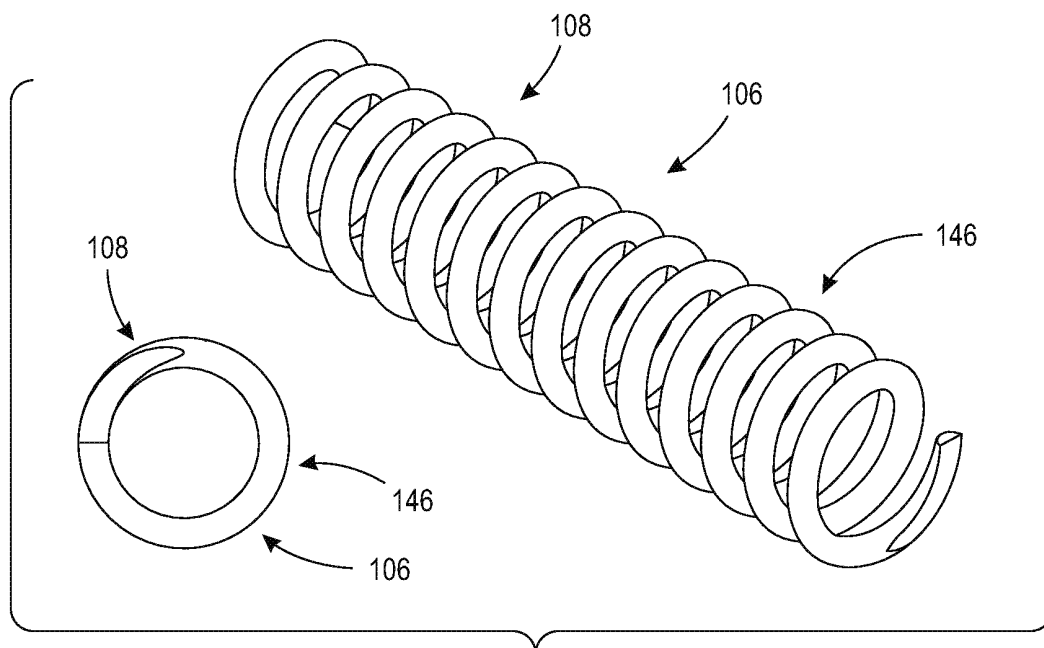

FIG. 10

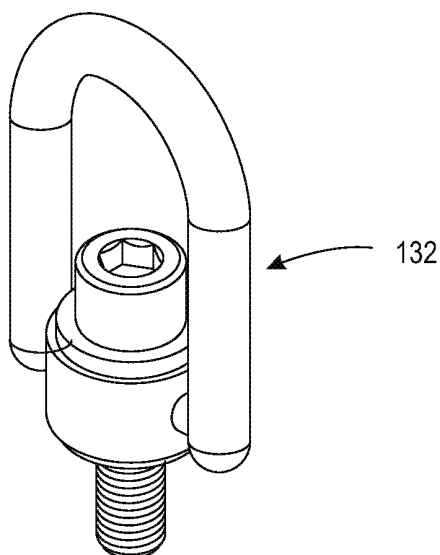

FIG. 11

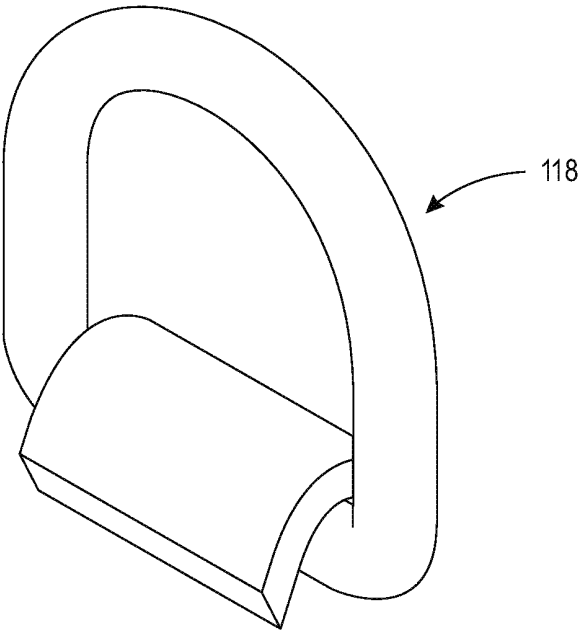

FIG. 12

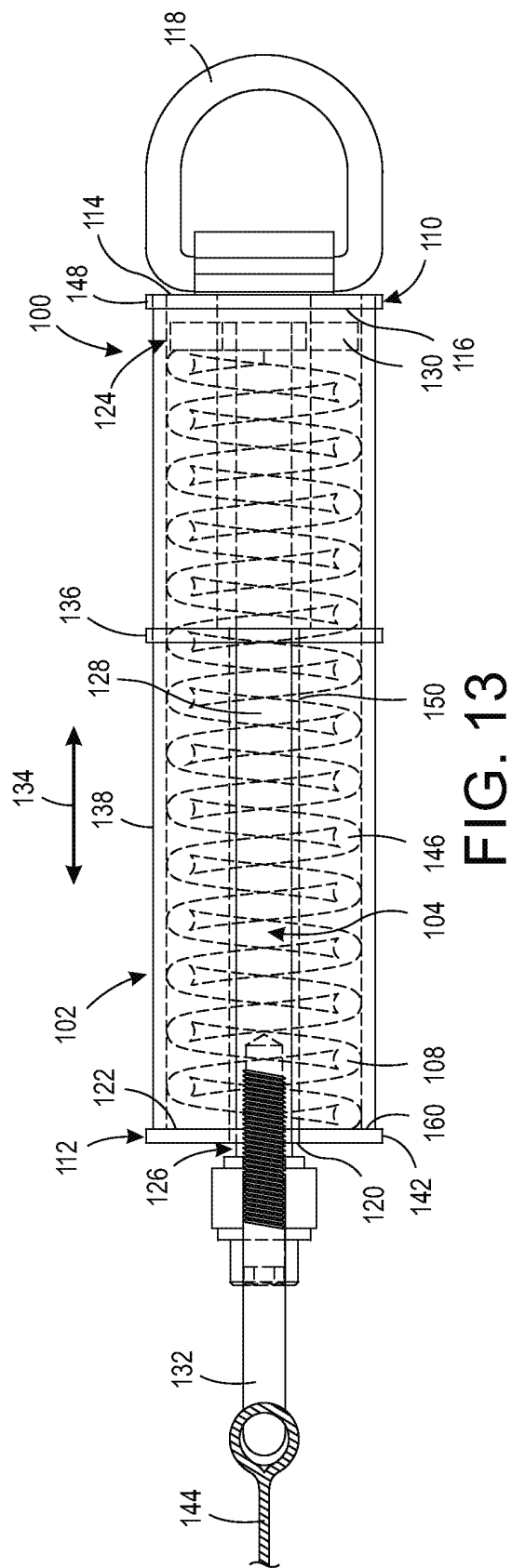

FIG. 13

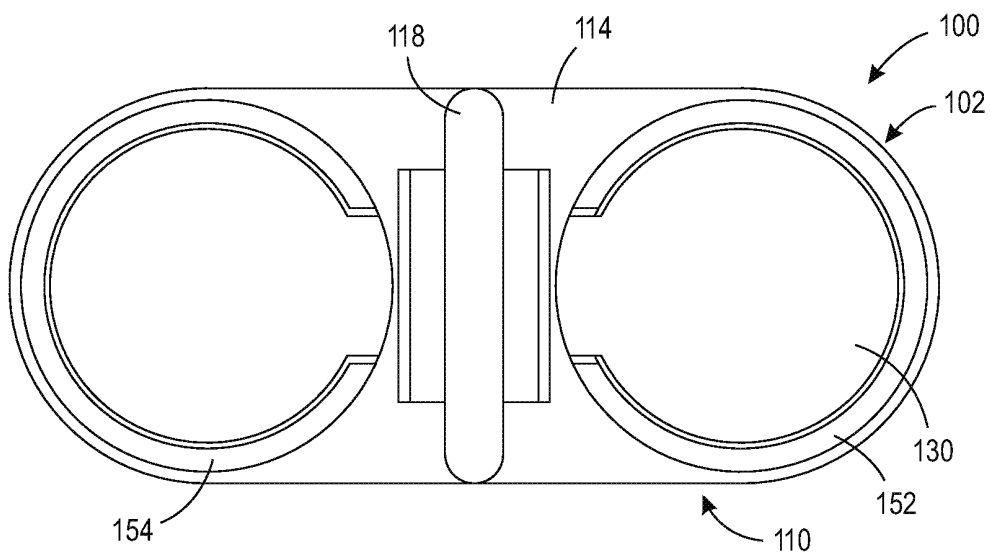

FIG. 14

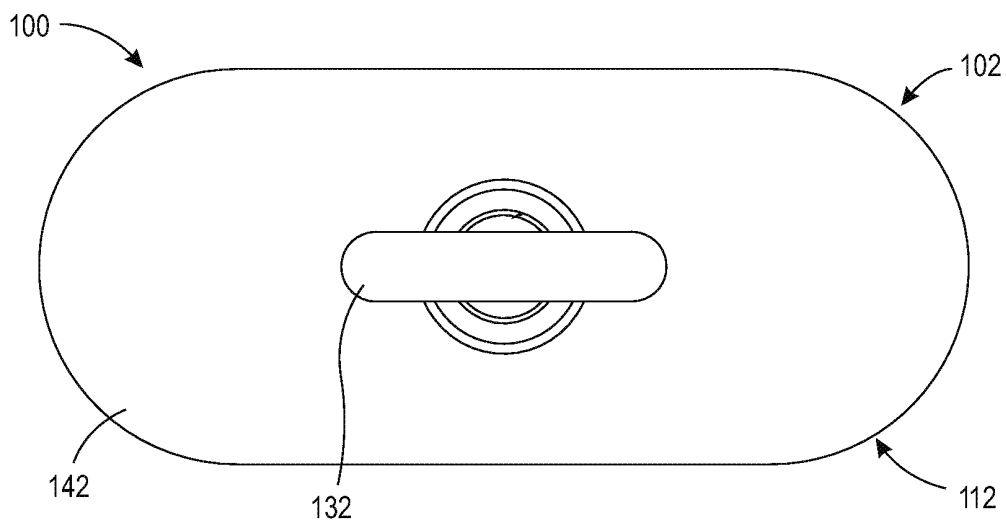

FIG. 15

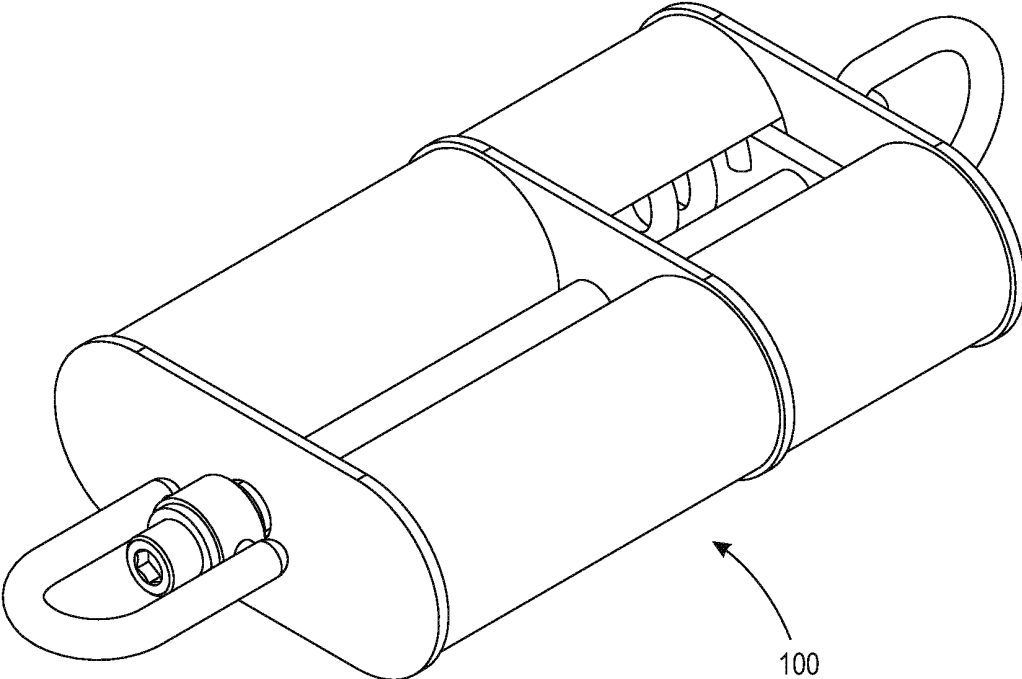

FIG. 16

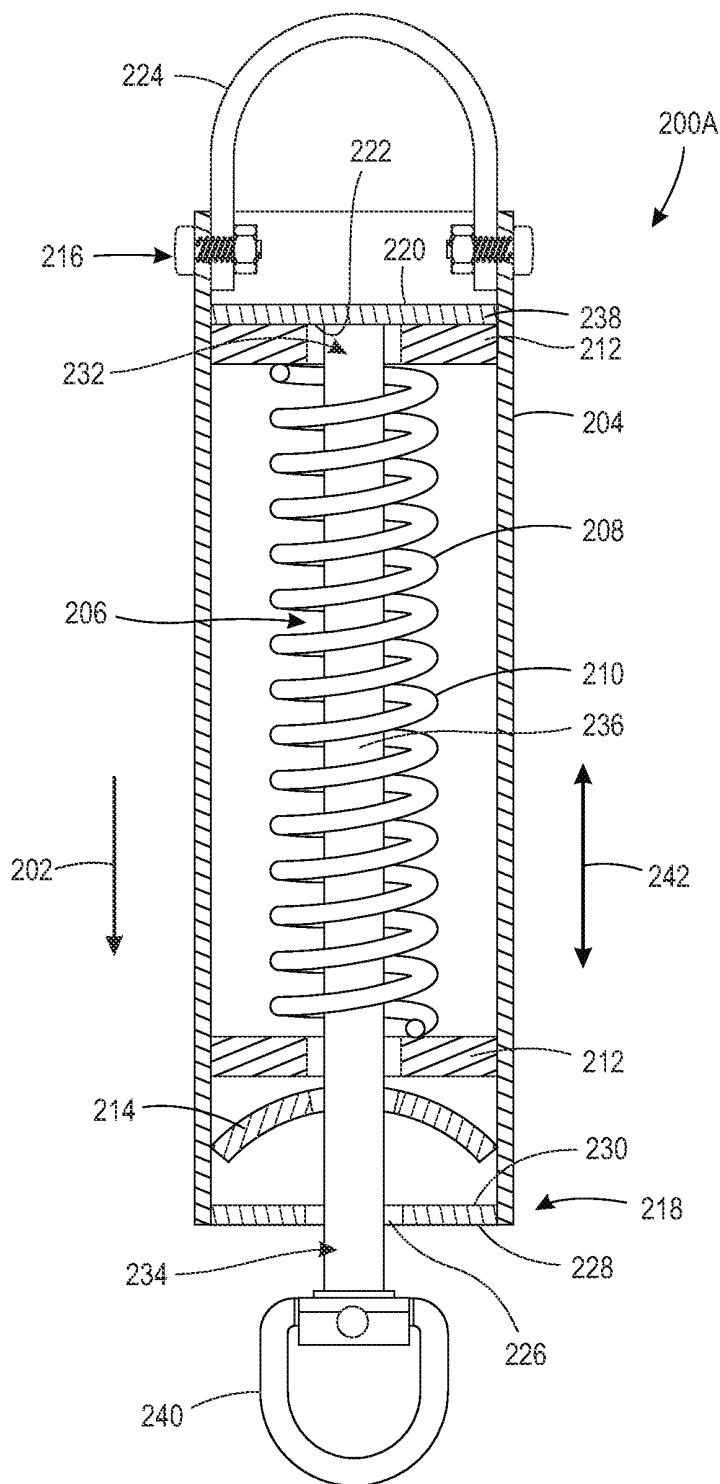

FIG. 17

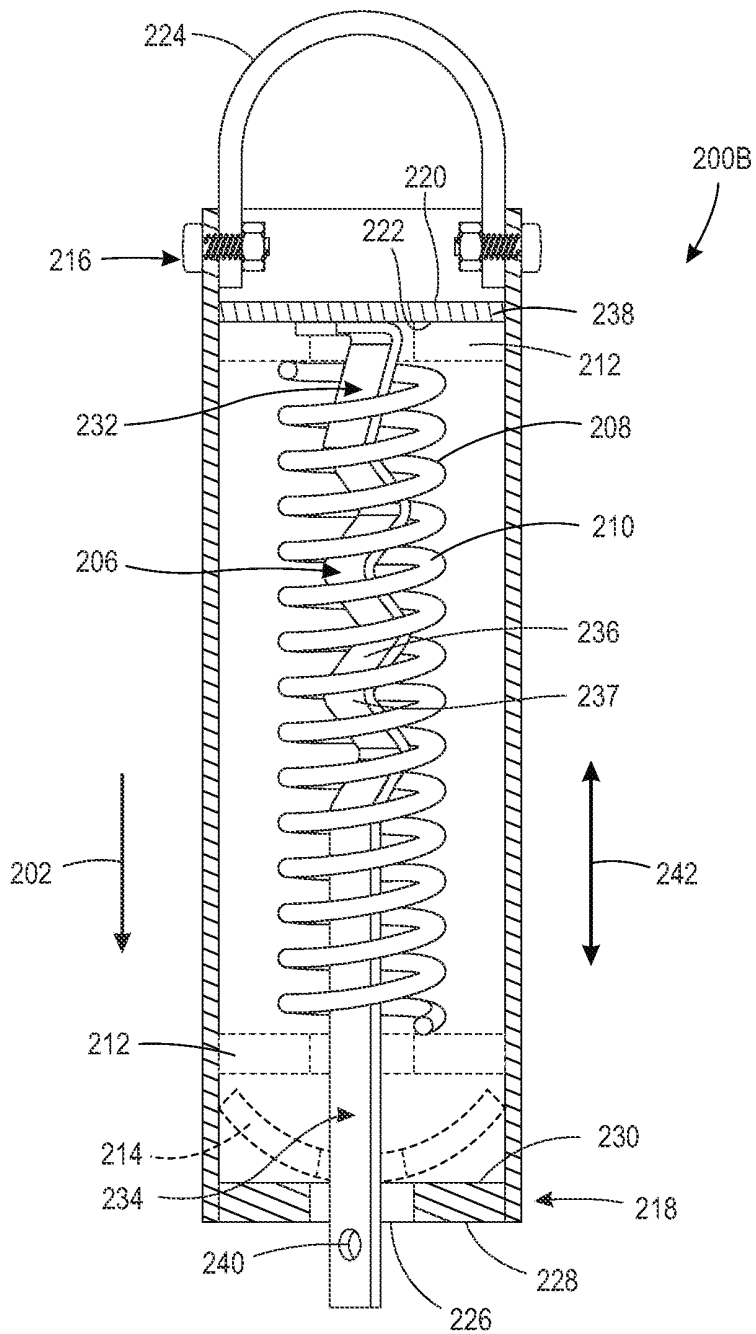

FIG. 18A

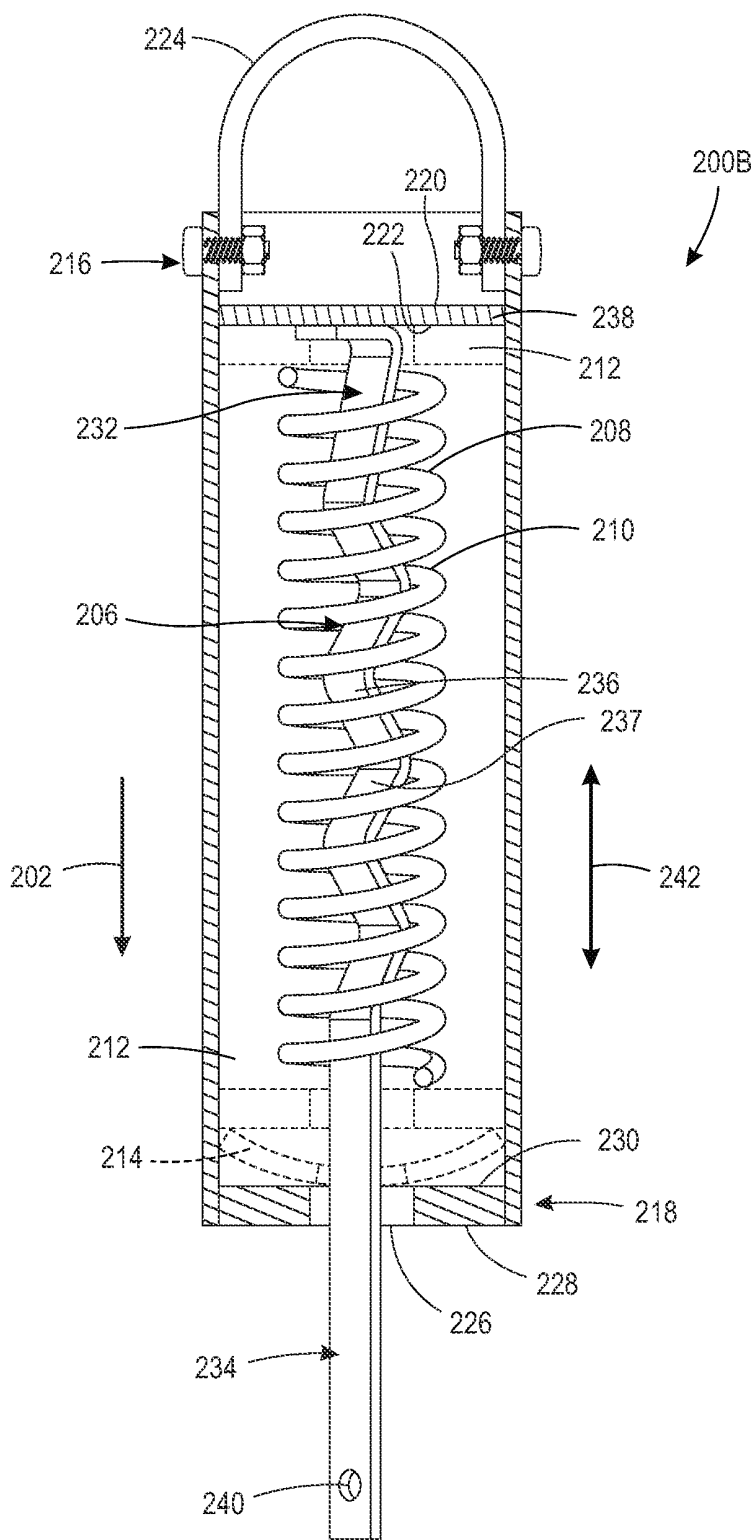

FIG. 18B

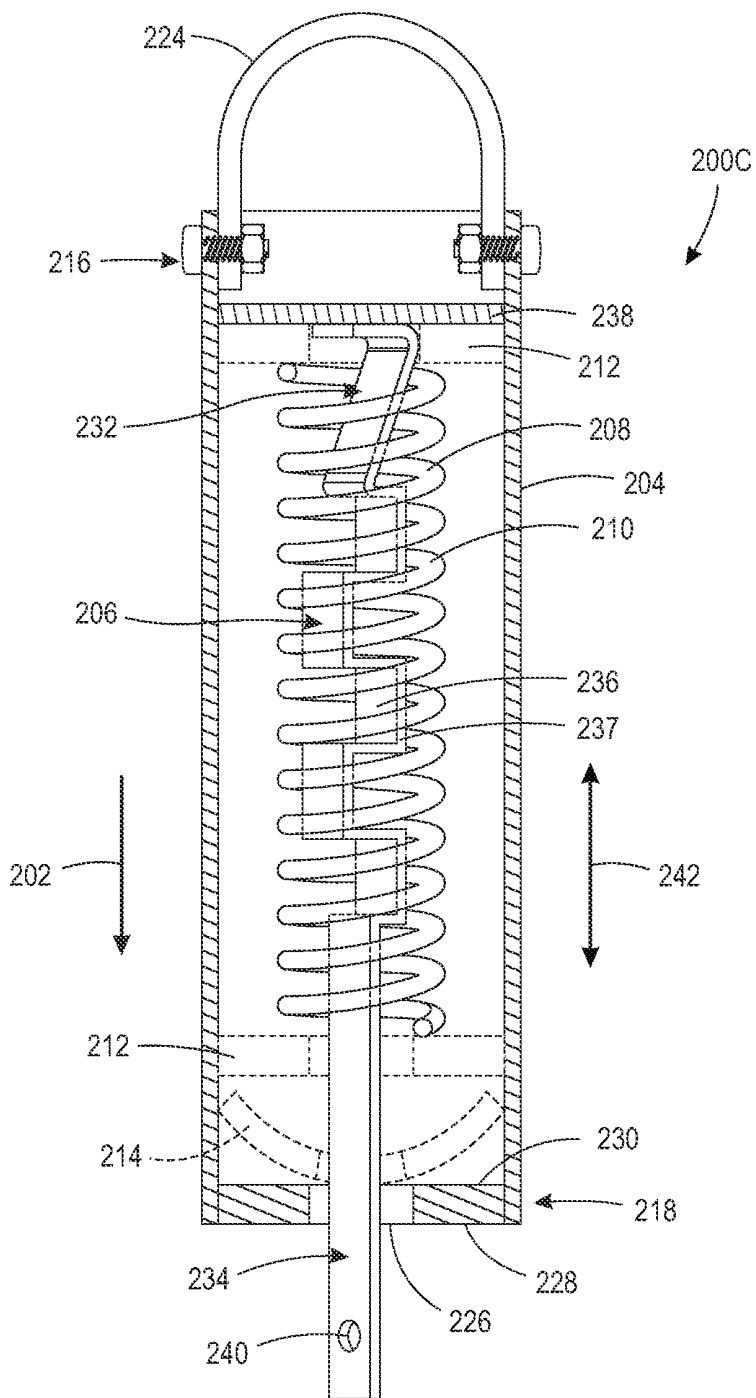

FIG. 19

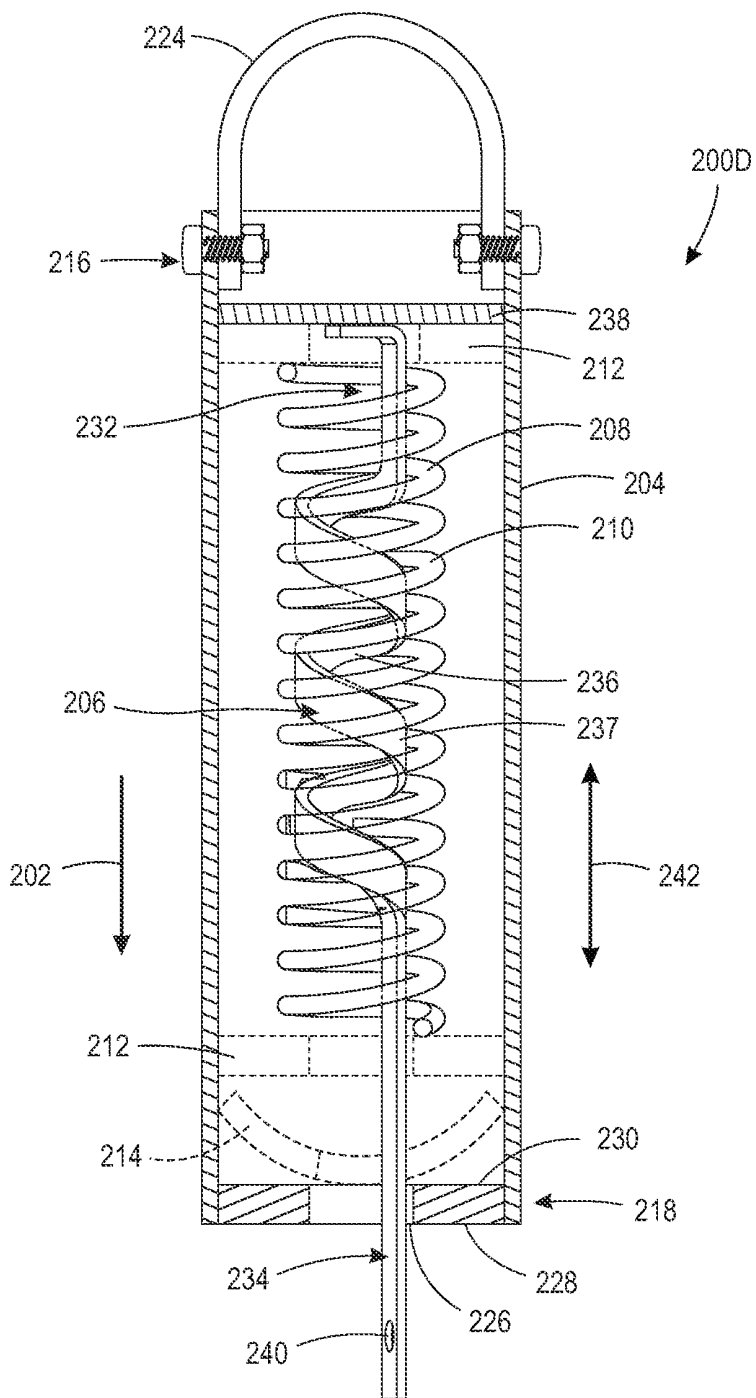

FIG. 20

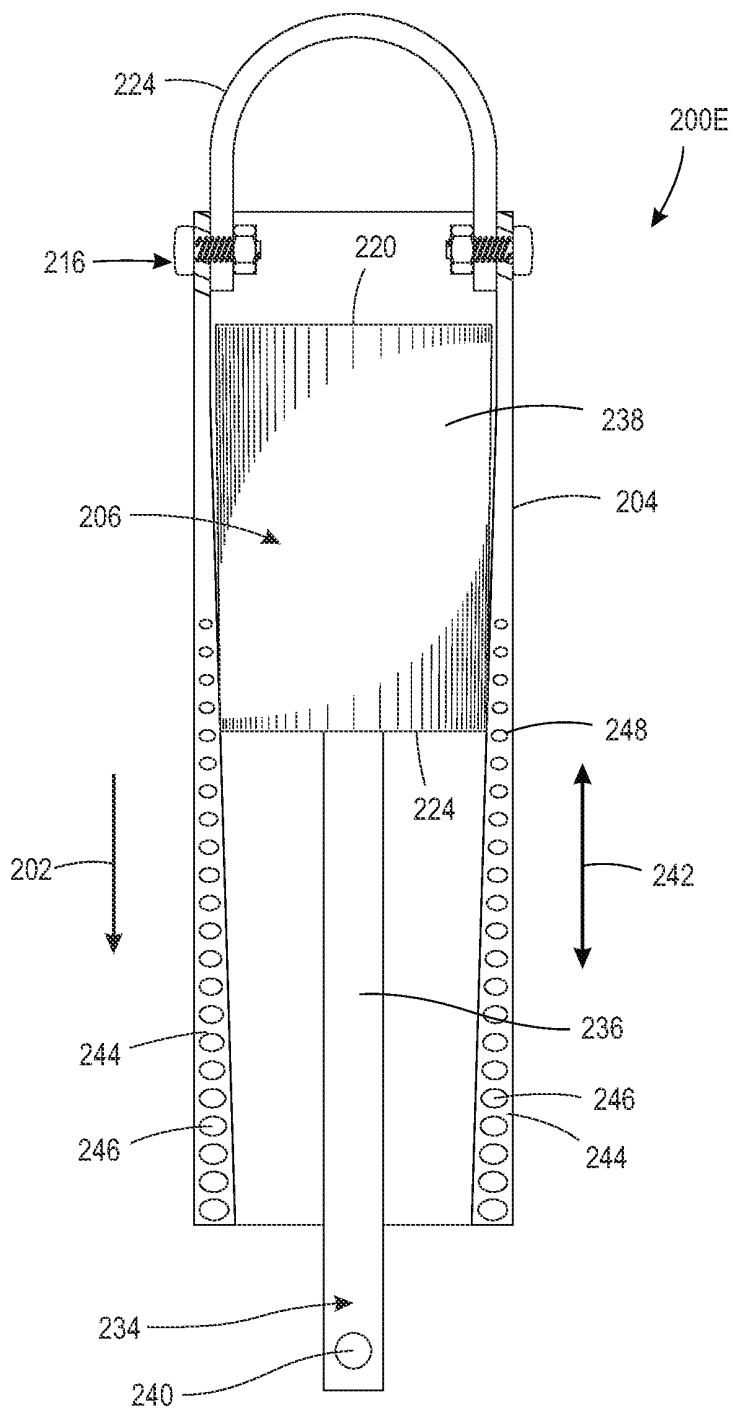

FIG. 21A

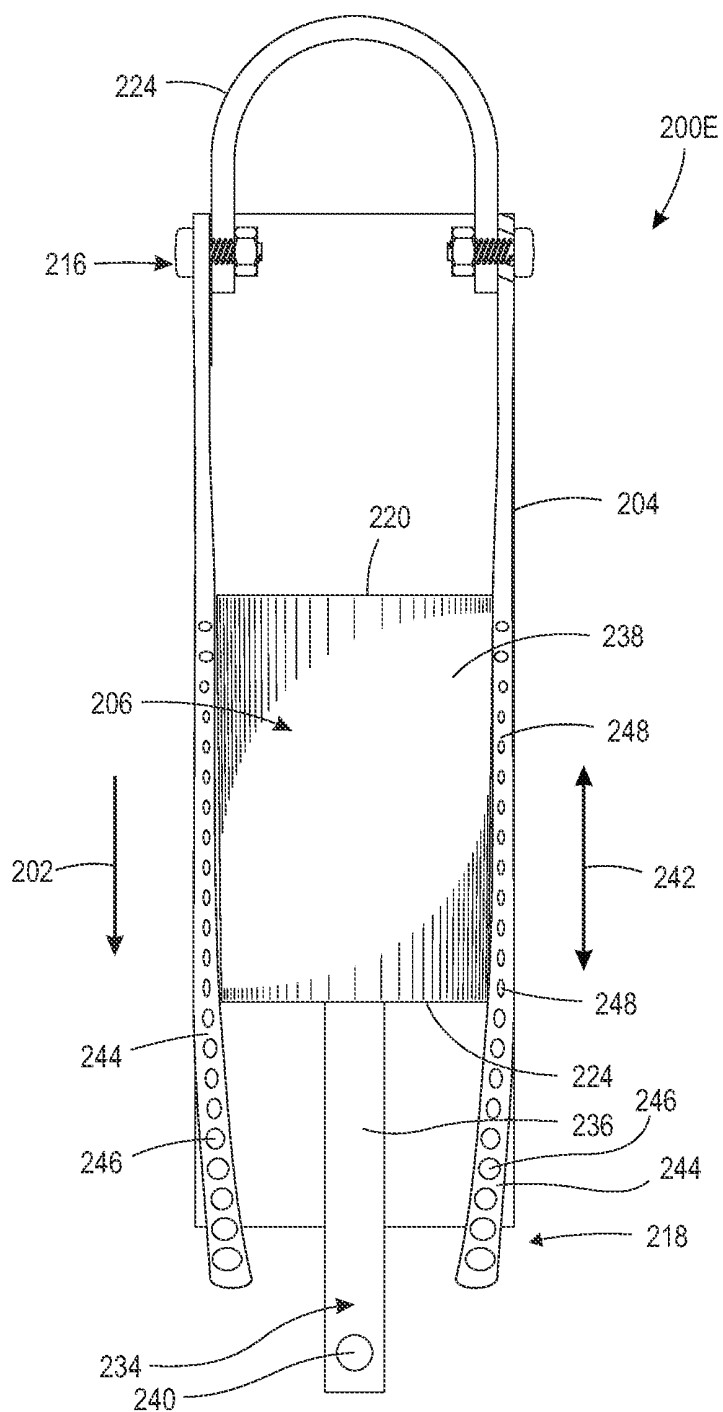

FIG. 21B

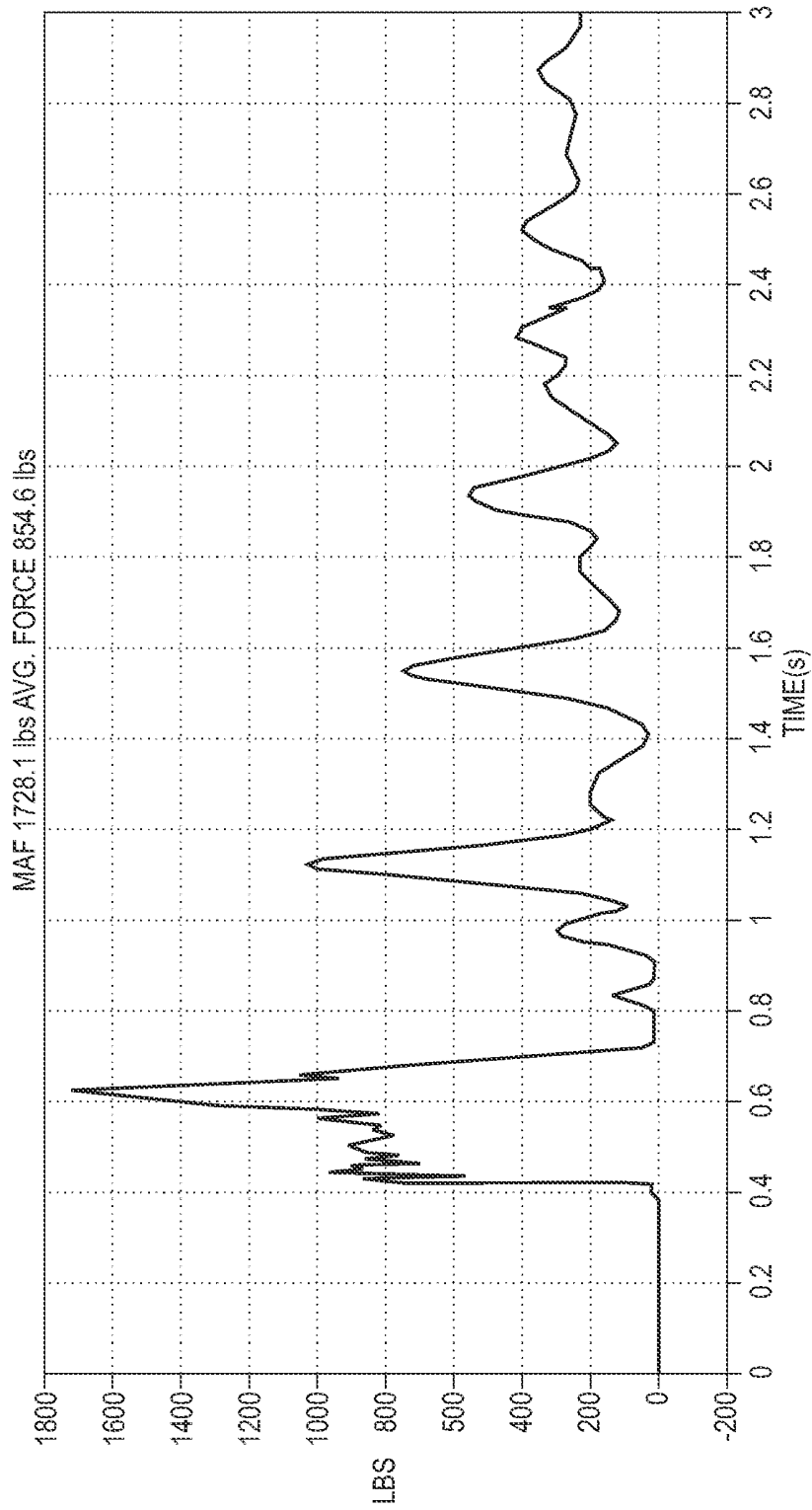

FIG. 22

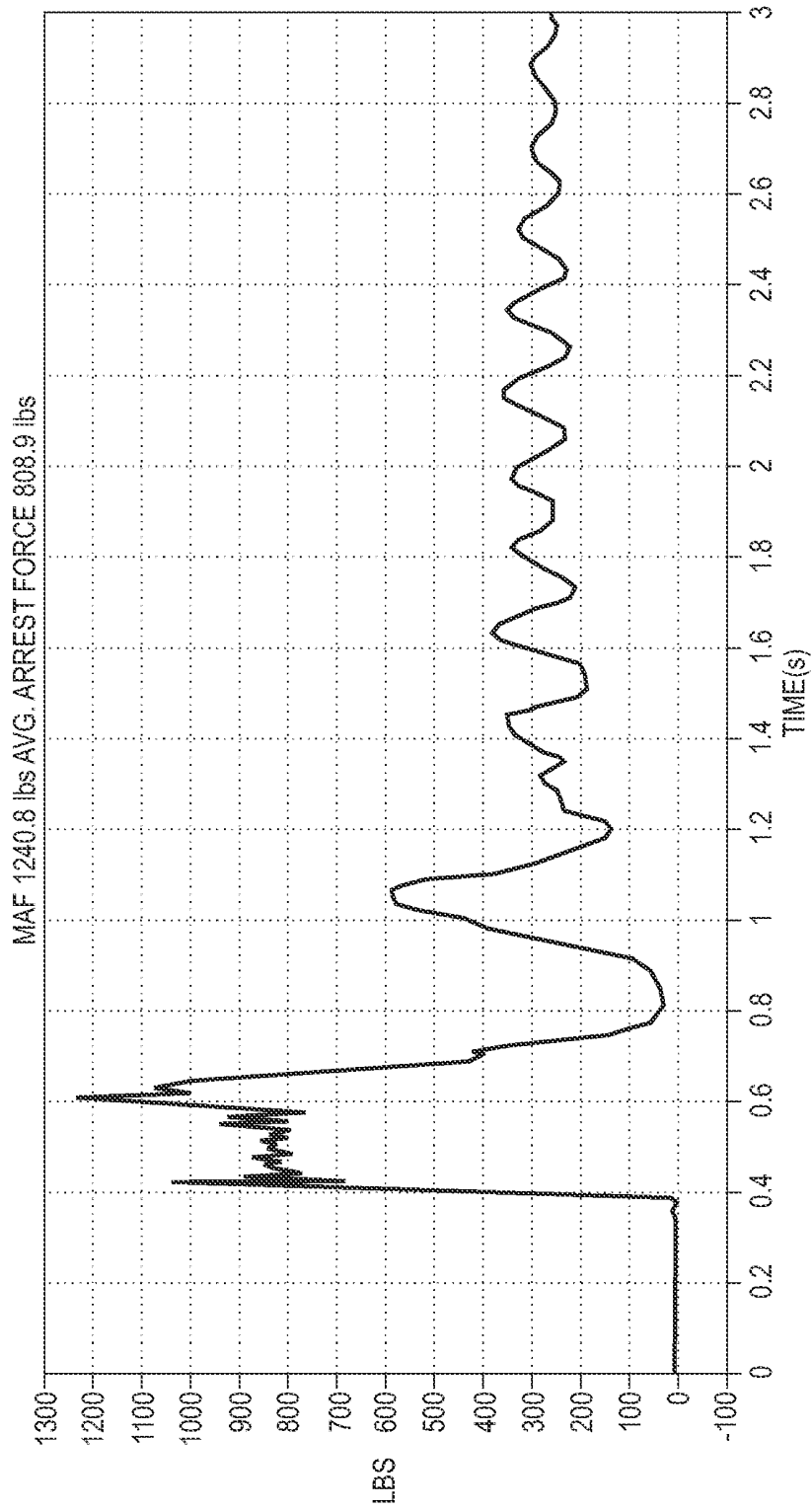

FIG. 23

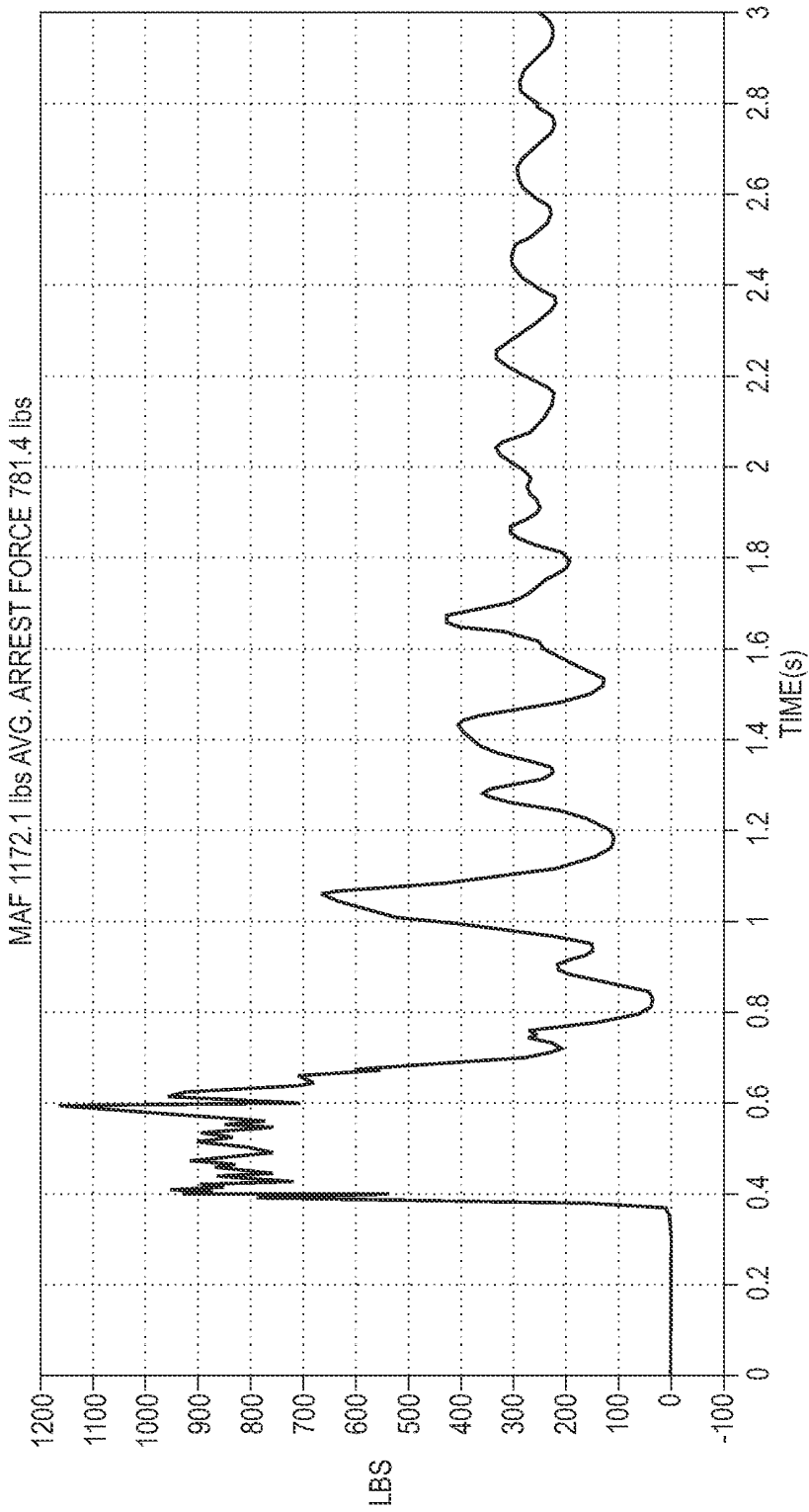

FIG. 24

# 1

## FORCE DAMPER

### CROSS-REFERENCE TO RELATED APPLICATIONS

This application is a divisional of U.S. patent application Ser. No. 16/784,939, filed Feb. 7, 2020, which application is a continuation-in-part of U.S. patent application Ser. No. 16/113,618, filed Aug. 27, 2018, which application claims the benefit under 35 U.S.C. § 119(e) of U.S. Provisional Patent Application No. 62/610,786, filed Dec. 27, 2017, each of which applications are incorporated herein by reference.

### FIELD

The invention broadly relates to a force damper, more specifically to a force damper used as a fall mitigation device, and even more particularly to a force damper used as a fall mitigation device having a single use, collapsible/compressible/compactable resilient member arranged to prevent reuse of the force damper after arresting a falling object, e.g., a roofing construction worker.

### BACKGROUND

Fall prevention and fall arrest systems are known in the art. For example, one such system includes a stretchable shock absorbing lanyard, e.g., Model No. 1340101 PRO™ Stretch Shock Absorbing Lanyard manufactured by Protecta®. The inner core of the device extends from about four and a half feet to about six feet while absorbing energy of a falling object. Although this device may be suitable in some situations, it cannot ensure safety in situations where the falling height is similar to the height of the object falling, e.g., a worker that is six feet falling off an elevated level of seven feet. However, heretofore, such damper devices were arranged to be reused over and over again.

Regulations and/or a desire to ensure worker safety have created a need for force damping systems that cannot be used more than a single time as the integrity of a previously used force damper cannot be verified. For example, a force damper used to slow the fall of a three hundred pound object may not perform effectively while slowing the fall of a three hundred pound object a second time, while the same force damper may perform repeatably when slowing the fall of a one hundred fifty pound object. Thus, there is a long-felt need for a force damper that is easy to operate, inexpensive to build, safe for its intended use and that precludes subsequent uses.

### SUMMARY

The present invention broadly comprises a force damper arranged to progressively arrest a first force imparted by an object moving in a first direction, the force damper including a housing, a driving member and a resilient member. The housing includes a first end and a second end, the first end having a first surface, a second surface opposite the first surface and a first connection point secured to the first surface, and the second end having a through bore and a third surface opposingly disposed relative to the second surface. The driving member includes a first end, a second end and a shaft therebetween, the first end comprises a stop and the second end comprises a second connection point. The resilient member is formed from a material that at least partially undergoes plastic deformation when the first force is arrested. The resilient member is disposed between the

# 2

stop and the third surface and imparts a second force on the stop toward the second surface.

The present invention also broadly comprises a force damper arranged to progressively arrest a first force imparted by an object moving in a first direction, the force damper including a housing, a driving member and first and second resilient members. The housing includes a first end and a second end, the first end having a first surface, a second surface opposite the first surface and a first connection point secured to the first surface, and the second end having a through bore and a third surface opposingly disposed relative to the second surface. The driving member includes a first end, a second end and a shaft therebetween, the first end having a stop and the second end having a second connection point. At least one of the first and second resilient members is formed from a material that at least partially undergoes plastic deformation when the first force is arrested. The first and second resilient members are disposed between the stop and the third surface and impart a second force on the stop toward the second surface.

These and other objects and advantages of the present invention will be readily appreciable from the following description of preferred embodiments of the invention and from the accompanying drawings and claims.

### BRIEF DESCRIPTION OF THE DRAWINGS

The nature and mode of operation of the present invention will now be more fully described in the following detailed description of the invention taken with the accompanying drawing figures, in which:

FIG. 1 is a side cross sectional view of an embodiment of a present force damper;

FIG. 2 is a top perspective view of an embodiment of a present force damper;

FIG. 3 is a front perspective, a side elevational and a front elevational view of an embodiment of a plate included in some embodiments of a present force damper;

FIG. 4 is a front perspective, a side elevational and a front elevational view of an embodiment of a plate included in some embodiments of a present force damper;

FIG. 5 is a front perspective, a side elevational and a front elevational view of an embodiment of a plate included in some embodiments of a present force damper;

FIG. 6 is a front perspective, a side elevational and a front elevational view of an embodiment of a tube included in some embodiments of a present force damper;

FIG. 7 is a front perspective, a side elevational and a front elevational view of an embodiment of a stop included in some embodiments of a present force damper;

FIG. 8 is a front perspective, a side elevational and a front elevational view of an embodiment of a tube included in some embodiments of a present force damper;

FIG. 9 is a front perspective, a side elevational and a front elevational view of an embodiment of a shaft included in some embodiments of a present force damper;

FIG. 10 is a front perspective and a front elevational view of an embodiment of a resilient member included in some embodiments of a present force damper;

FIG. 11 is a front perspective view of an embodiment of a connection point included in some embodiments of a present force damper;

FIG. 12 is a front perspective view of an embodiment of a connection point included in some embodiments of a present force damper;

FIG. 13 is a side cross sectional view of an embodiment of a present force damper;

FIG. 14 is a front elevational view of an embodiment of a present force damper;

FIG. 15 is a back elevational view of an embodiment of a present force damper;

FIG. 16 is a top perspective view of an embodiment of a present force damper;

FIG. 17 is a side cross sectional view of an embodiment of a present force damper;

FIGS. 18A and 18B are side cross-sectional views of embodiments of a present force damper before (FIG. 18A) and after (FIG. 18B) application of a force upon a driving member shaft;

FIG. 19 is a side cross sectional view of an embodiment of a present force damper;

FIG. 20 is a side cross sectional view of an embodiment of a present force damper;

FIGS. 21A and 21B are side cross-sectional views of embodiments of a present force damper before (FIG. 21A) and after (FIG. 21B) application of a force upon a driving member shaft; and,

FIGS. 22-24 are graphical representations of results of drop tests of present embodiments of force dampers described herein.

### DETAILED DESCRIPTION

At the outset, it should be appreciated that like drawing numbers on different drawing views identify identical, or functionally similar, structural elements of the invention. While the present invention is described with respect to what is presently considered to be the preferred aspects, it is to be understood that the invention as claimed is not limited to the disclosed aspects.

Furthermore, it is understood that this invention is not limited to the particular methodologies, materials and modifications described and as such may, of course, vary. It is also understood that the terminology used herein is for the purpose of describing particular aspects only, and is not intended to limit the scope of the present invention, which is limited only by the appended claims.

Unless defined otherwise, all technical and scientific terms used herein have the same meaning as commonly understood to one of ordinary skill in the art to which this invention belongs. Although any methods, devices or materials similar or equivalent to those described herein can be used in the practice or testing of the invention, the preferred methods, devices, and materials are now described.

It should be understood that use of “or” in the present application is with respect to a “non-exclusive” arrangement, unless stated otherwise. For example, when saying that “item x is A or B,” it is understood that this can mean one of the following: (1) item x is only one or the other of A and B; (2) item x is both A and B. Alternately stated, the word “or” is not used to define an “exclusive or” arrangement. For example, an “exclusive or” arrangement for the statement “item x is A or B” would require that x can be only one of A and B. Moreover, as used herein, the phrases “comprises at least one of” and “comprising at least one of” in combination with a system or element is intended to mean that the system or element includes one or more of the elements listed after the phrase. For example, a device comprising at least one of: a first element; a second element; and, a third element, is intended to be construed as any one of the following structural arrangements: a device comprising a first element; a device comprising a second element; a device comprising a third element; a device comprising a first element and a second element; a device comprising a

first element and a third element; a device comprising a first element, a second element and a third element; or, a device comprising a second element and a third element. A similar interpretation is intended when the phrase “used in at least one of:” is used herein. Furthermore, as used herein, “and/or” is intended to mean a grammatical conjunction used to indicate that one or more of the elements or conditions recited may be included or occur. For example, a device comprising a first element, a second element and/or a third element, is intended to be construed as any one of the following structural arrangements: a device comprising a first element; a device comprising a second element; a device comprising a third element; a device comprising a first element and a second element; a device comprising a first element and a third element; a device comprising a first element, a second element and a third element; or, a device comprising a second element and a third element.

It should be appreciated that the term “substantially” is synonymous with terms such as “nearly,” “very nearly,” “about,” “approximately,” “around,” “bordering on,” “close to,” “essentially,” “in the neighborhood of,” “in the vicinity of” etc., and such terms may be used interchangeably as appearing in the specification and claims. It should be appreciated that the term “proximate” is synonymous with terms such as “nearby,” “close,” “adjacent,” “neighboring,” “immediate,” “adjoining,” etc., and such terms may be used interchangeably as appearing in the specification and claims. The term “approximately” is intended to mean values within ten percent of the specified value.

By “non-rotatably connected” elements, we mean that: the elements are connected so that whenever one of the elements rotate, all the elements rotate; and relative rotation between the elements is not possible. Radial and/or axial movement of non-rotatably connected elements with respect to each other is possible, but not required. Additionally, “plastic deformation” is intended to mean instances when a sufficient load is applied to a material that causes a permanent change in shape to that material.

Adverting now to the figures, it should be appreciated that the figures depict various embodiments of the present force damper. The elevated work surface, e.g., roof, the falling object, e.g., a worker, a tool, a container filled with materials, etc., are not shown in the figures. One of ordinary skill in the art will readily appreciate the type, form and arrangement of each of the foregoing structures and therefore depiction in the figures is unnecessary. For the purpose of clarity in the detailed description, these structures are not included in the figures; however, the structures are discussed herebelow.

The present invention broadly includes force damper 50 arranged to progressively arrest a first force imparted by an object moving in a first direction, i.e., the direction depicted by arrow 51. Force damper 50 comprises housing 52, driving member 54 and resilient member 56. Housing 52 comprises first end 58 and second end 60. First end 58 includes first surface 62, second surface 64 opposite first surface 62 and first connection point 66 secured to first surface 62. Second end 60 includes through bore 68 and third surface 70 opposingly disposed relative to second surface 64. Driving member 54 comprises first end 72, a second end 74 and shaft 76 therebetween. First end 72 comprises stop 78 and second end 74 comprises second connection point 80. Resilient member 56 is formed from a material that at least partially undergoes plastic deformation when the first force is arrested. Resilient member 56 is disposed between stop 78 and third surface 70 and imparts

a second force on stop **78** toward second surface **64** and on second end **60** toward third surface **70**, as depicted by bi-directional arrow **82**.

In some embodiments, housing **52** encloses resilient member **56**. In some embodiments, second end **60** of housing **52** comprises block **84**. Block **84** comprises through bore **68** and third surface **70**. In some of these embodiments, block **84** is formed from a urethane material. Thus, block **84** may provide force damping in addition to that of resilient member **56**. It should be appreciated that block **84** may also be formed from a rigid material, e.g., a metal, and in those embodiments block **84** does not provide additional force damping.

In some embodiments, resilient member **56** is a resilient polymer, a leaf collapsible, a shock absorber, and/or a compression spring, e.g., compression spring **86**. In some of these embodiments, resilient member **56** is compression spring **86**, and in some of these embodiments, compression spring **86** is formed from a chrome silicon steel material. In some embodiments, the compression springs described herein are between 4-12". In some embodiments, the compression springs described herein may be formed from elastomeric compounds such as elastomeric plastics, etc.

In some embodiments, force damper **50** further comprises securing line **88** selected from the group of: a rope, a cable, and/or a tether, and securing line **88** may in turn be connected to a harness and/or a belt. Subsequently, the object to be secured, e.g., a worker, a tool, a container, etc., is secured directly to the rope, cable and/or tether, or alternatively, secured directly to the harness and/or belt. It should be appreciated that securing line **88** is depicted as a rope only and that the structure and form of a cable and/or a tether are readily apparent to one having ordinary skill in the art and therefore depiction in the figures is unnecessary. Similarly, depiction of a subsequent harness and/or belt is also unnecessary. It should be further appreciated that various types of securing lines are more suitable for the present force damper, e.g., stretchable and/or shock absorbing ropes, as additional force may be damped by these types of securing lines. However, including such types of securing lines is not required.

In other embodiments, the present invention broadly includes force damper **100** arranged to progressively arrest a first force imparted by an object moving in a first direction, i.e., the direction depicted by arrow **101**. Force damper **100** comprises housing **102**, driving member **104** and first and second resilient members **106** and **108**, respectively. Housing **102** comprises first end **110** and second end **112**. First end **110** includes first surface **114**, second surface **116** opposite first surface **114** and first connection point **118** secured to first surface **114**. Second end **112** includes through bore **120** and third surface **122** opposingly disposed relative to second surface **116**. Driving member **104** comprises first end **124**, second end **126** and shaft **128** therebetween. First end **124** comprises stop **130** and second end **126** comprises second connection point **132**. At least one of first and second resilient members **106** and **108**, respectively, is formed from a material that at least partially undergoes plastic deformation when the first force is arrested. In other terms, one or both of first and second resilient members **106** and **108**, respectively, undergoes plastic deformation while arresting the first force. Thus, one of the resilient members may be arranged to arrest a portion of the force and display visible, permanent deformation while the other resilient member provides force damping while undergoing only elastic deformation, i.e., temporary shape change with restoration to its original shape after damping is complete. First

and second resilient members **106** and **108**, respectively, are disposed between stop **130** and third surface **122**, and impart a second force on stop **130** toward second surface **116** and on second end **112** toward third surface **122**, as depicted by bi-directional arrow **134**.

In some embodiments, housing **102** further comprises reinforcement plate **136** arranged between first and second ends **110** and **112**, respectively, of housing **102**. In some embodiments, housing **102** at least partially encloses first and second resilient members **106** and **108**, respectively. It should be appreciated that "partially encloses" is depicted in the figures in that tubes **138** include open portions **140** which permit the linear actuation of stop **130** as force damper **100** arrests the first force imparted by the object moving in the first direction. In some embodiments, second end **112** of housing **102** comprises plate **142**. Plate **142** comprises through bore **120**. In some embodiments, force damper **100** further comprises securing line **144** selected from the group of: a rope, a cable, and/or a tether, and securing line **144** may in turn be connected to a harness and/or a belt. Subsequently, the object to be secured, e.g., a worker, a tool, a container, etc., is secured directly to the rope, cable and/or tether, or alternatively, secured directly to the harness and/or belt. It should be appreciated that securing line **144** is depicted as a rope only and that the structure and form of a cable and/or a tether are readily apparent to one having ordinary skill in the art and therefore depiction in the figures is unnecessary. Similarly, depiction of a subsequent harness and/or belt is also unnecessary. It should be further appreciated that various types of securing lines are more suitable for the present force damper, e.g., stretchable and/or shock absorbing ropes, as additional force may be damped by these types of securing lines. However, including such types of securing lines is not required.

In some embodiments, stop **130** extends perpendicularly from shaft **128** towards first and second resilient members **106** and **108**, respectively. As such, it should be appreciated that stop **130** is positioned between first and second resilient members **106** and **108**, respectively, and second surface **116**.

In some embodiments, first and second resilient members **106** and **108**, respectively, are formed from a resilient polymer, a leaf spring, a shock absorber, and/or a compression spring, e.g., compression spring **146**. In some of these embodiments, resilient members **106** and **108** are compression spring **146**, and in some of these embodiments, compression spring **146** is formed from a chrome silicon steel material. In some embodiments, the compression springs described herein are between 4-12". In some embodiments, the compression springs described herein may be formed from elastomeric compounds such as elastomeric plastics, etc.

Although the foregoing clearly sets forth the structure and function of various embodiments of the present force damper, a further description of the components of one of the embodiments may be helpful to further understand how the device functions. In various embodiments, force damper **100** may include a variety of additional components and such components are not required in all embodiments. However, it should be appreciated that it is possible to include all or some of the components described below in a single embodiment if desired.

In view of the foregoing, force damper **100** may include plate **148**, reinforcement plate **136**, plate **142**, tubes **138**, stop **130**, tube **150**, shaft **128**, resilient members **106** and **108**, and connection points **118** and **132**. When all of the foregoing components are included in force damper **100**, the following non-limiting arrangement is just one of the pos-

sibilities. Tubes **138** partially enclose resilient members **106** and **108**. Tubes **138** are passed through openings **152** and **154** in plate **148** and subsequently through openings **156** and **158** in reinforcement plate **136** until ends **160** of tubes **138** abut plate **142**. Connection point **118** is fixedly secured to plate **148**. Stop **130**, which is secured to end **124** of shaft **128**, is positioned within openings **140** of tubes **138** and between resilient members **106** and **108** and plate **148**. The foregoing arrangement permits the linear movement of stop **130** against resilient members **106** and **108** when force damper **100** is arresting a first force imparted by an object moving in a first direction. Reinforcement plate **136** may further include opening **162** wherein tube **150** is passed until it abuts plate **142**. Tube **150** provides an unrestricted passage for shaft **128** during its linear displacement. Moreover, the combination of reinforcement plate **136**, tube **150** and plate **142** strengthens the overall structure of force damper **100**. Plate **142** may include through bore **120** adjacent to the abutment of tube **150**. Through bore **120** provides access to second end **126** of shaft **128** and thereby a means to secure connection point **132** to shaft **128**. As can be appreciated in view of the foregoing, the pathway of force through the device is: connection point **118** to plate **148** to tubes **138** to plate **142** to resilient members **106** and **108** to stop **130** to shaft **128** to connection point **132**. It is this arrangement that permits the damping of force between connection points **118** and **132**, in this particular embodiment.

The foregoing arrangement results in a force damper that solves problems presented by regulatory agencies and worker safety concerns, i.e., a force damper in a fall mitigation system should only be used one time. The foregoing embodiments provide force damping over a reduced range of travel, e.g., the present force damper travels approximately three to six inches while absorbing the force of a falling object. Heretofore, existing force damping systems required far greater distance to damp the force of a falling object, e.g., two and a half to three feet. It should be appreciated that the present force damper system may be configured to travel lesser or greater lengths depending on the needs of the system. All the various resilient members described above may provide some elastic deformation, the resilient members are selected for particular falling masses that will always impart plastic deformation on at least one of the resilient members while they arrest a first force imparted by an object moving in a first direction. For example, one set of resilient members may be rated for arresting the force created by a falling object ranging from 100 kilograms (kg) to 150 kg, while a different set of resilient members may be rated for falling objects ranging from 150 kg to 200 kg. It is critical that at least one of the resilient members experiences plastic deformation so that single use of each the devices can be ensured. The plastic deformation of at least one of the resilient members with no return to its original shape/size provides a readily observable characteristic of the present force damper that ensures a user of the device can determine if it has been previously used for its intended purpose, i.e., arresting the force created by an object moving in a first direction.

Referring now to FIGS. **17-24**, further present embodiments of a force damper can include, for example, one or more resilient members used in association with a so-called Belleville washer having a frustoconical shape, driving member shafts including zig-zag-like, sinusoidal-like, or helical-like portions that may be elongated and plastically deformed upon application of a force to thereby attenuate the force applied thereto, or so-called compressible/collapsible/compactible crumple zones configured to be com-

pressed/collapsed/compactified to thereby absorb/attenuate a force applied to the driving member shaft. It should be appreciated that while FIGS. **17-24** primarily illustrate embodiments of a force damper comprising a single housing and single driving member, etc., such embodiments comprise can more than a single housing and driving member shaft, and, for example, may comprise so-called dual-housing type embodiments.

As shown in FIG. **17**, for example, force damper **200A** is arranged to progressively arrest a first force imparted by an object moving in a first direction, i.e., the direction depicted by arrow **202**. Force damper **200A** comprises housing **204**, driving member **206** and resilient member **208**. Housing **204** comprises first end **216** and second end **218** and may be fabricated from materials such as steel, aluminum, other lightweight metals, fiberglass, carbon fiber, composites, or combinations thereof. First end **216** includes first surface **220**, second surface **222** opposite first surface **220** and first connection point **224** connected to housing **204**, for purposes of, for example, securing the force damper to a fixed structure or a fall arrest apparatus. Second end **218** includes through bore **226** and third surface **230** oppositely disposed relative to second surface **222**. Driving member **206** comprises first end **232**, a second end **234** and driving member shaft **236** therebetween. First end **232** comprises driving member stop **238** and second end **234** comprises second connection point **240** for purposes of, for example, securing an object or person thereto by means of a rope, cable, webbing, lanyard, tear-away lanyard, etc. (not shown). Resilient member **208** is formed from a material that at least partially undergoes plastic deformation when the first force is arrested. Resilient member **208** is disposed between driving member stop **238** and third surface **230** of housing end wall **228** and imparts a second force on driving member stop **238** toward second surface **222** and on second end **218** toward third surface **230**, as depicted by bi-directional arrow **242**.

In some embodiments, housing **204** encloses resilient member **208**. In some embodiments, one or more of first end **216** and second end **218** of housing **204** can comprise one or more semi-resilient members **212**. Semi-resilient members **212** comprise a through bore allowing driving member shaft **236** to pass therethrough. In some of these embodiments, semi-resilient members **212** are formed from a urethane material which serves to further attenuate a force applied to the driving member **206**. In some embodiments, semi-resilient member **212** is composed of 60 durometer urethane, or like compound, having a thickness between  $\frac{3}{8}$  and  $\frac{1}{2}$ ". Thus, semi-resilient members **212** may provide force damping in addition to that of resilient member **208**. In some embodiments, semi-resilient member **212**, e.g. a urethane washer, can be configured to be less compressible/extendable and/or resilient as compared to resilient member **208**, e.g., a spring member, and can exhibit no deformation, exhibit partial deformation, or exhibit deformation when the first force is arrested, which deformation can be elastic or plastic deformation. As shown in FIG. **17**, a force damper may further include a so-called Belleville washer **214**, which is disposed within housing **204** between driving member stop **238** and end wall **228** of housing **204**. Belleville washer **214** has a frustoconical shape and includes a through bore allowing the driving member shaft **236** to pass therethrough. Belleville washer **214** can be formed from a plastically deformable material with no return to its original shape/size, such as a metal, plastics, polymers, from sacrificial/fracturable/frangible materials, or combinations thereof so as to provide a readily observable characteristic as to whether the

force damper has been subject to prior use. Along this line, housing 204 may include a viewing window or slit proximate the location of Belleville washer 214 so to allow ready inspection thereof. It should be appreciated that while FIG. 17 illustrates Belleville washer 214 as being disposed between semi-resilient member 212 and end wall 228 of second end 218 of housing 204, it may be positioned otherwise within housing 204 and at any position between end wall 228 and driving member stop 238. In some cases, Belleville washer 214 can be formed of an elastically deformable material that returns to its original shape. Additionally, while FIG. 17 illustrates Belleville washer 214 being positioned such that its concave side is disposed toward end wall 218, it may be positioned such that its concave side is oppositely positioned toward driving member stop 238. Also, while only a single Belleville washer 214 is shown in FIG. 17, more than one Belleville washer 214 may be utilized depending upon the specific application, i.e., the object and/or the amount of force to be attenuated/arrested. Where more than one Belleville washer 214 is utilized, they may be positioned to contact one another in a stacked, or nested-type arrangement, positioned such that they contact one another but do not nest with one another, positioned in such a way that they do not contact one another, e.g. on opposite ends of housing 204, or combinations thereof depending upon the specific application.

In some embodiments, resilient member 208 is a resilient polymer, a leaf spring, a shock absorber, and/or a compression spring, e.g., compression spring 210. In some of these embodiments, resilient member 208 is compression spring 210, and in some of these embodiments, compression spring 210 is formed from a chrome silicon steel material. In some embodiments, the compression springs described herein are between 4-12". In some embodiments, the compression springs described herein may be formed from elastomeric compounds such as elastomeric plastics, etc.

In some embodiments, force damper 220A further comprises a securing line (not shown) selected from the group of: rope, cable, webbing, tether, lanyard, tear-away lanyard, combinations thereof, etc., and the securing line may in turn be connected to a harness and/or a belt. Subsequently, the object to be secured, e.g., a worker, a tool, a container, etc., is secured directly to the securing line rope, cable and/or tether, or alternatively, secured directly to the harness and/or belt. It should be further appreciated that various types of securing lines may be more suitable for the present force damper, e.g., stretchable and/or shock absorbing ropes, tear away lanyards, as additional force may be damped by these types of securing lines. However, including such types of securing lines is not required.

As shown in FIGS. 18A-20, force dampers 200B-200D are substantially similar to force damper 220A, but are primarily different in that they can include differently configured driving member shafts 236, which are configured to be elongated upon application of a sufficient force in the first direction 202. That is, as force dampers 200A-200D include similar structural elements, discussion of such similar structural elements is not re-presented herein, and the following description is substantially limited to a discussion of the differences between embodiments 200A-200D.

As shown in FIGS. 18A-20 force dampers 200B-200D are generally configured to comprise plastically deformable and elongatable driving member shafts 236 including zig-zag/sinusoidal/helical-like portions 237 positioned between driving member first end 232 and driving member second end 234. As may be appreciated, in such embodiments, the driving member shaft 236 can be formed from a plastically

deformable material that does not allow return to its original shape/size, such as a metal or certain polymers, from other sacrificial/non-reusable materials, or combinations thereof so as to provide a readily observable characteristic as to whether the force damper has been subject to prior use. As may be further appreciated, housing 204 may include a viewing window or slit proximate location of zig-zag/sinusoidal/helical-like portions 237 so to allow ready inspection thereof (not shown) such that operational state may be readily determined. In some aspects, however, driving member shafts 236 may be elastically deformable such that they substantially return to their original shapes.

As also shown in FIGS. 18A-20, in the case of plastically deformable driving member shafts, the driving member shafts 236 including zig-zag/sinusoidal/helical-like portions 237 can be formed from a generally flat stock and include zig-zag-like folded/pleated portions 237 in the case of FIGS. 18A and 18B, square sinusoidal-type portions 237 in the case of FIG. 19, and helical-type portions 237 in the case of FIG. 20. As may be appreciated from FIGS. 18A and 18B, for example, prior to a force being applied to driving member shaft 236 including zig-zag-like folded/pleated portions 237 in first direction 202, zig-zag-like folded/pleated portions 237 are maintained in a so-called start position. However, as shown in FIG. 18B, upon application of a sufficient force, zig-zag-like folded/pleated portions 237 become elongated and are plastically deformed at the ending position shown by way of example in FIG. 18B. Such elongation and plastic deformation serves to both further attenuate/dampen the force applied in the first direction, that may result from a falling object or person, and in the case of plastic deformation, also serves as an indicator that the force damper has been previously utilized. While not shown in any of FIGS. 18A-20, driving member shafts 236 including zig-zag-like folded/pleated portions 237 can also be configured to include, for example, markings, colored markings, knurling, etching, etc. along a length thereof, for example, proximate through bore 226 of housing, to show whether the force damper has been previously utilized and the driving member shafts 236 elongated and subject to plastic deformation. For example, where the force damper has not been utilized, a colored marking proximate through bore 226 could be green in color to show that the force damper remains available for use, or red to indicate that it has been previously used and should be discarded. Additionally, it should be further appreciated that driving member shafts 236 including zig-zag/sinusoidal/helical-like portions 237 can be formed of stock of varying thickness and/or varying number of folds/pleats/turns based on the particular application and/or object that is secured thereto. In some embodiments, the driving member shafts 236 are formed from 1/8" steel. Furthermore, as shown in FIGS. 18A-20, force dampers including driving member shafts 236 including zig-zag/sinusoidal/helical-like portions 237 can also optionally include semi-resilient members 212 and/or Belleville washers 214 (as shown by the dashed lines in such figures).

Turning now to FIGS. 21A and 21B, force damper 200E, and other embodiments of force dampers described herein, may be configured to comprise a so-called collapsible/compressible/compactable crush zone configured to reduce or attenuate the amount of force applied in first direction 202. As shown by way of example in FIGS. 21A and 21B, force damper 200E can be configured to include driving member 206 having a driving member stop 238 having a tapered shape for purposes of contacting a collapsible/compressible/compactable tapered wall 244 of housing 204. As shown in such figures, collapsible/compressible/com-

pactable tapered wall **244** can include, for example, channels or interstitial portions **248** disposed between structural portions **244** thereof such that upon action by the tapered driving member stop **238**, such walls may collapse/compress/compact upon themselves and/or may be partially directionally disposed toward second end **218** as shown in FIG. **21B**. As may be appreciated, such so-called collapsible/compressible/compactable crush zones may be configured to comprise a structural member of the housing, e.g., a wall of the housing itself, or may be configured to comprise a member or zone secured, disposed on, or adhered to an inner wall of housing **204**. As may be further appreciated, collapsible/compressible/compactable zone **244** may be formed of metals, polymers, foams, resilient materials, fractureable or frangible materials, or combinations thereof. Additionally, while FIGS. **21A** and **21B** illustrate a force damper as comprising a so-called collapsible/compressible/compactable crush zone only, such zones may be used in association with one or more of the force damper embodiments or aspects thereof previously discussed herein. Walls of the housing and/or tapered wall **244** may also be configured in a stepped fashion, for example, to ensure that a collapsible/compressible/compactable member or zone secured, disposed on, or adhered to an inner wall of housing **204** is not dislodged as a result of the application of a force in the first direction.

Referring now to FIGS. **22-24**, which are graphical illustrations of drop tests performed according to ANSI Z359 requirements in order to assess the dampening or attenuation of force provided by force dampers in accordance with the instant disclosure. In each of the drop tests of FIGS. **22-24**, a 282 pound weight was utilized, the weight dropped from a same height free and clear of obstructions, and each force damper included a driving member shaft including a zig-zag-like folded portion as shown, for example, in FIGS. **18A** and **18B**. In some tests, one or more of a Belleville washer and/or one or more urethane semi-resilient members were utilized. As shown in FIG. **22**, a dual housing/double spring force damper utilizing a 10" tear away/ripstop-type lanyard exhibited a Maximum Arresting Force (MAF)=1728.1 pounds and an Average Arresting Force (AAF)=854.6 pounds. As shown in FIG. **23**, a single housing/single spring force damper utilizing a 10" tear away/ripstop-type lanyard exhibited a Maximum Arresting Force (MAF)=1240.8 pounds and an Average Arresting Force (AAF)=808.9 pounds. Finally, as shown in FIG. **24**, a dual housing/double spring force damper utilizing a 12" tear away/ripstop-type lanyard exhibited a Maximum Arresting Force (MAF)=1172.1 pounds and an Average Arresting Force (AAF)=781.4 pounds. The aforementioned tests indicate that a force damper in accordance with instant disclosure comprises an improvement over currently known force dampers.

Thus, it is seen that the objects of the present invention are efficiently obtained, although modifications and changes to the invention should be readily apparent to those having ordinary skill in the art, which modifications are intended to be within the spirit and scope of the invention as claimed. It also is understood that the foregoing description is illustrative of the present invention and should not be considered as limiting. Therefore, other embodiments of the present invention are possible without departing from the spirit and scope of the present invention.

PARTS LIST

- 50** Force Damper
- 51** 1<sup>st</sup> Direction/Force

- 52** Housing
- 54** Driving Member
- 56** Resilient Member
- 58** 1<sup>st</sup> End
- 60** 2<sup>nd</sup> End
- 62** 1<sup>st</sup> Surface
- 64** 2<sup>nd</sup> Surface
- 66** 1<sup>st</sup> Connection Point
- 68** Through bore
- 70** 3<sup>rd</sup> Surface
- 72** Driving Member 1st End
- 74** Driving Member 2<sup>nd</sup> End
- 76** Driving Member Shaft
- 78** Driving Member Stop
- 80** 2<sup>nd</sup> Connection Point
- 82** 2<sup>nd</sup> Direction/Force
- 84** Block
- 86** Compression Spring
- 88** Securing Line
- 100** Force Damper
- 101** Direction/Force
- 102** Housing
- 104** Driving Member
- 106** 1<sup>st</sup> Resilient Member
- 108** 2<sup>nd</sup> Resilient Member
- 110** Housing 1<sup>st</sup> End
- 112** Housing 2<sup>nd</sup> End
- 114** 1<sup>st</sup> Surface
- 116** 2<sup>nd</sup> Surface
- 118** 1<sup>st</sup> Connection Point
- 120** Through bore
- 122** 3<sup>rd</sup> Surface
- 124** Driving Member 1<sup>st</sup> End
- 126** Driving Member 2<sup>nd</sup> End
- 128** Driving Member Shaft
- 130** Driving Member Stop
- 132** 2<sup>nd</sup> Connection Point
- 134** 2<sup>nd</sup> Direction/Force
- 136** Reinforcement Plate
- 138** Tube(s)
- 140** Tube Open Portion
- 142** 2<sup>nd</sup> End Plate
- 144** Securing Line
- 146** Compression Spring
- 148** 1<sup>st</sup> End Plate
- 150** Tube
- 152** Opening
- 154** Opening
- 156** Opening
- 158** Opening
- 160** Tube **138** End
- 162** Opening
- 200A-200E** Force Damper
- 202** 1<sup>st</sup> Direction/Force
- 204** Housing
- 206** Driving Member
- 208** Resilient Member
- 210** Compression Spring
- 212** Semi-Resilient Member (Washer)
- 214** Belleville Washer
- 216** 1<sup>st</sup> End
- 218** 2<sup>nd</sup> End
- 220** 1<sup>st</sup> Surface
- 222** 2<sup>nd</sup> Surface
- 224** 1<sup>st</sup> Connection Point
- 226** Through Bore
- 228** End Wall

- 230 3<sup>rd</sup> Surface
- 232 Driving Member 1<sup>st</sup> End
- 234 Driving Member 2<sup>nd</sup> End
- 236 Driving Member Shaft
- 237 Zig-zag/Sinusoidal/Helical-like Portion
- 238 Driving Member stop
- 240 2<sup>nd</sup> Connection Point
- 242 2<sup>nd</sup> Direction/Force
- 244 Collapsible/Compressible/Compactable Portion
- 246 Structural Portion
- 248 Interstitial Portion

What is claimed is:

1. A force damper operatively arranged for a single-use when a first force is applied to the force damper in a first direction, the force damper providing a readily observable characteristic that the first force has been applied to the force damper in the first direction, the force damper arranged to progressively arrest the first force applied in the first direction, the force damper comprising:

- a housing enclosure comprising a first housing end and a second housing end, the first housing end including a first connection point, and the second housing end including an opening;
- a driving member disposed within the housing enclosure and comprising a first shaft end, a second shaft end, and a shaft therebetween, the first shaft end comprising a stop and the second shaft end comprising a second connection point; and,
- an elastically compressible member disposed within the housing enclosure between the stop and the opening, the elastically compressible member formed from a material that at least partially undergoes plastic deformation upon first application of the first force in the first direction and the first force is arrested, the elastically

compressible member imparting a second force on the stop toward first housing end when the first force is applied, and,

wherein, when the first force is applied and arrested, the at least partial plastic deformation of the elastically compressible member provides the readily observable characteristic that the first force has been applied to the force damper.

2. The force damper of claim 1, wherein the elastically compressible member comprises one or more of a compression spring, a semi-resilient member, or a Belleville washer.

3. The force damper of claim 1 comprising a plurality of elastically compressible members including at least each of a compression spring, a semi-resilient member, and a Belleville-washer, the second housing end opening comprising a through bore in an end wall thereof, and the second shaft end passes through the through bore.

4. The force damper of claim 3, wherein the semi-resilient member and the Belleville washer are disposed between the stop and the end wall.

5. The force damper of claim 3, comprising a first semi-resilient member and a second semi-resilient member, wherein the first semi-resilient member is disposed between a first terminal end of the compression spring and the stop, and the second semi-resilient member is disposed between a second terminal end of the compression spring opposite the first end, and the end wall.

6. The force damper of claim 3, wherein the semi-resilient member comprises a urethane washer.

7. The force damper of claim 3, wherein the Belleville washer is composed of one or more of a polymer, a metal, a frangible or fracturable material, or combinations thereof.

\* \* \* \* \*