



US005826956A

United States Patent [19]

[11] Patent Number: **5,826,956**

Norton

[45] Date of Patent: **Oct. 27, 1998**

[54] FOLLOWER FOR FILE DRAWER

FOREIGN PATENT DOCUMENTS

[75] Inventor: **Allen Norton**, Salamanca, N.Y.

1220630 5/1960 France 220/544

[73] Assignee: **Signore, Incorporated**, Ellicottville, N.Y.

Primary Examiner—Peter R. Brown
Assistant Examiner—Hanh V. Tran
Attorney, Agent, or Firm—Bean, Kauffman & Snyder

[21] Appl. No.: **938,870**

[57] ABSTRACT

[22] Filed: **Sep. 26, 1997**

[51] Int. Cl.⁶ **B65D 25/04**

[52] U.S. Cl. **312/183; 312/348.3; 220/544**

[58] Field of Search 312/183, 193, 312/348.3, 348.5; 220/543, 544, 545, 546

In the combination of a file drawer having a pair of spaced-apart vertical side walls formed with recessed guide channels extending lengthwise of each side wall between front and rear ends of the file drawer; and a follower having a body portion sized to be received within the file drawer with a pair of spaced side edges thereof arranged adjacent the side walls and a pair of guide members upstanding from said body portion adjacent the side edges and sized and arranged for receipt within the guide channels and for movement lengthwise thereof; the improvement comprising a mounting opening extending through one of the side walls in alignment with the guide channel thereof, the opening being sized to permit at least a portion of one of the guide members to project outwardly therethrough to a degree sufficient to accommodate installation of the follower within the file drawer by inserting the follower into the file drawer to assume a starting position with the body portion arranged at an angle of other than 90° relative to the side walls and the one guide member arranged to project outwardly through the opening and then twisting the follower to assume an installed position with the body portion arranged at an angle of approximately 90° relative to the side walls and the guide members positioned within the guide channels.

[56] References Cited

U.S. PATENT DOCUMENTS

- 1,227,172 5/1917 Moore .
- 2,281,067 4/1942 Bergman 220/545
- 2,501,491 3/1950 Beno .
- 3,109,432 11/1963 Regenhardt .
- 3,227,504 1/1966 Dunham .
- 3,450,304 6/1969 Schreyer 220/546 X
- 3,499,695 3/1970 Studinski 312/330.1 X
- 3,612,337 10/1971 Harger .
- 4,303,286 12/1981 McClellan 220/546 X
- 4,305,217 12/1981 Green et al. 220/544 X
- 4,735,324 4/1988 Wilcek 220/544 X
- 4,881,653 11/1989 Norton .
- 5,111,959 5/1992 Glickman .
- 5,312,180 5/1994 Tieder et al. .
- 5,366,283 11/1994 Crose 312/183
- 5,433,336 7/1995 Kristoffersson .

8 Claims, 2 Drawing Sheets

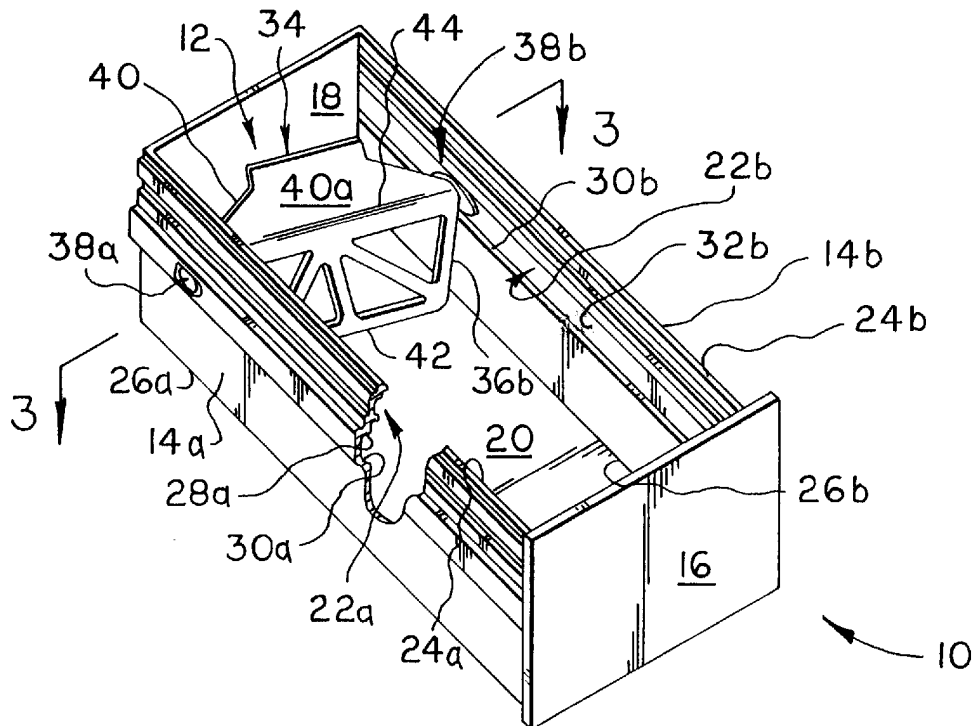

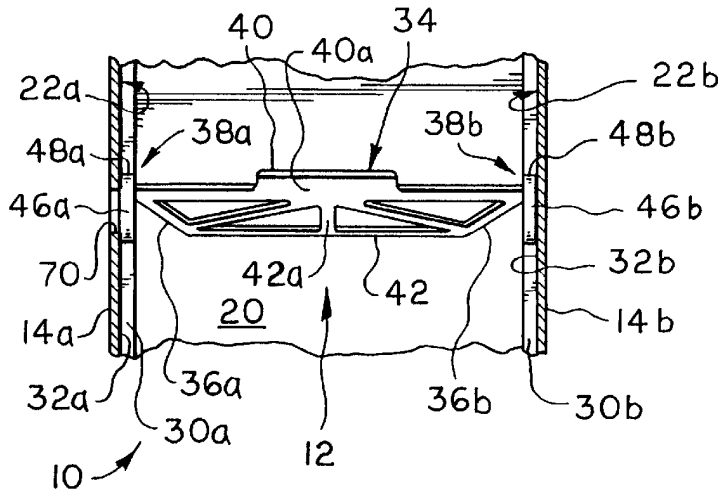

FIG. 4

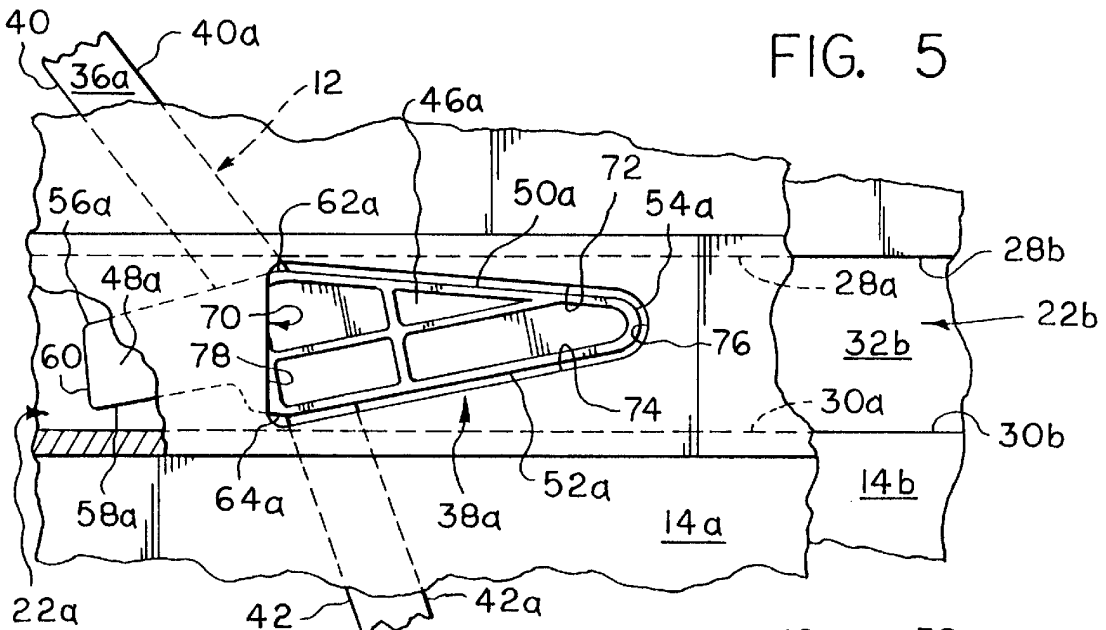

FIG. 5

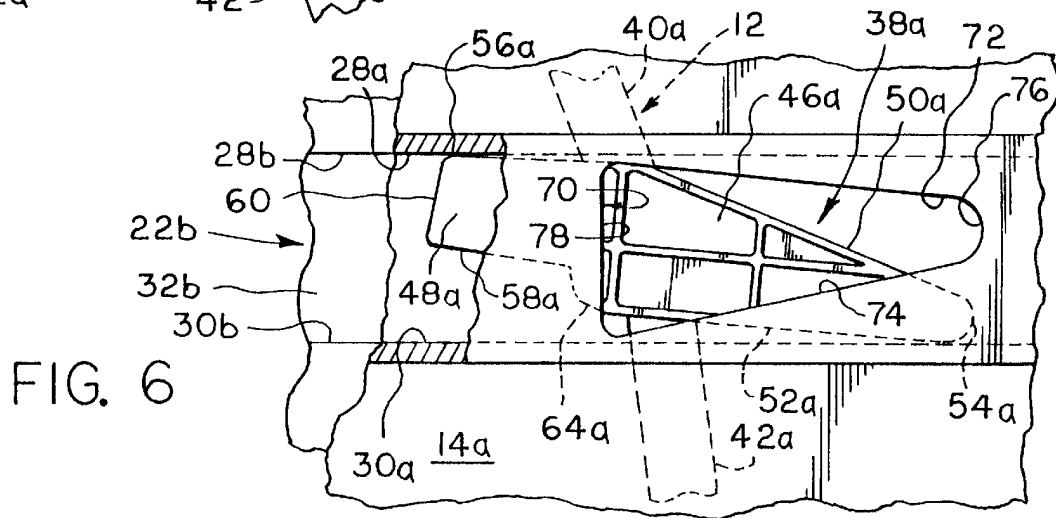

FIG. 6

FOLLOWER FOR FILE DRAWER

BACKGROUND OF THE INVENTION

The present invention relates to the construction of file drawers of the type commonly used for retaining file folders upstanding in an orderly fashion within the drawer. In a typical construction, an adjustable follower is formed with a body portion, which extends transversely across the interior of the file drawer between its sidewalls, and a pair of guide members, which are arranged to project normal to the body portion and are slidably received within a pair of guide channels arranged to extend lengthwise of the side walls between front and rear ends of the file drawer.

In prior constructions of the type having guide members formed integrally with the body portion, it is known to assemble the follower within a file drawer by inserting the follower between the side walls, before the front wall or rear wall is joined to the side walls and by spreading apart resilient metal side walls of a fully assembled file drawer sufficiently to receive the follower therebetween. It is also known that a follower formed of flexible plastic material may be physically deformed incident to insertion thereof within the file drawer, whereafter the follower is permitted to return to its as-formed condition.

SUMMARY OF THE INVENTION

The present invention relates to an improved file drawer and follower construction allowing a fully assembled follower to be installed within a fully assembled file drawer without requiring deformation of either the file drawer or the follower.

In accordance with the present invention, one side wall of a file drawer is formed with a mounting opening, which is aligned with its guide channel and sized and arranged to allow at least a portion of one of the guide members of the follower to project outwardly therethrough to a degree sufficient to accommodate installation of the follower. Specifically, the follower is inserted into the file drawer to assume a starting position, wherein the body portion of the follower is arranged at an angle other than 90° relative to the side walls and the one guide member is arranged to project outwardly through the mounting opening. The follower is then twisted to assume an installed position, wherein the body portion is arranged at an angle of approximately 90° relative to the side walls and the guide members are positioned within the guide channels for sliding movement lengthwise thereof.

The guide members engage with guide surfaces of the guide channels to define forward and rearward tilted positions of the follower within the file drawer, wherein items stored within the file drawer intermediate the follower and the front of the drawer, and in engagement with the follower, tend to move the follower into its forward tilted position, wherein the follower is temporarily locked against movement lengthwise within the file drawer. Preferably, in all tilted positions of the follower, excepting one position at or adjacent to the rearward tilted position of the follower, the shape and orientation of mounting opening is such as to prevent twisting of the follower from its installed position into its starting position, thereby to avoid unintended disassembly of the follower relative to the file drawer.

BRIEF DESCRIPTION OF THE DRAWINGS

The nature and mode of operation of the present invention will now be more fully described in the following detailed description taken with the accompanying drawings wherein:

FIG. 1 is a prospective view showing a follower placed in a file drawer to assume a starting position;

FIG. 2 is a view similar to FIG. 1, but showing the follower after it is twisted to assume an installed position;

FIG. 3 a sectional view taken generally along the line 3—3 in FIG. 1;

FIG. 4 is a sectional view taken generally along the line 4—4 in FIG. 2;

FIG. 5 is a side elevational view of one side of the file drawer showing its follower mounting opening and the follower arranged to assume a rearward tilted position; and

FIG. 6 is a view similar to FIG. 5, but showing the follower arranged in its forward tilted position.

DETAILED DESCRIPTION

The present invention is shown in the drawings as comprising a file drawer 10 in combination with a follower 12, wherein the file drawer is conventional from the standpoint that it includes a pair of spaced apart side walls 14a and 14b having their opposite ends joined to front and rear end walls 16 and 18, and arranged together with the front and rear walls to upstand from a rectangular bottom wall 20. In a typical construction, side walls 14a and 14b are formed with facing guide channels 22a and 22b, which extend lengthwise of the side walls intermediate their upper and lower edges 24a, 26a and 24b, 26b, respectively. The guide channels 22a and 22b are in turn defined by facing upper and lower guide surfaces 28a, 30a and 28b, 30b, respectively, which are joined by connecting surfaces 32a and 32b.

Follower 12 generally includes a body portion 34 having a pair of spaced side edges 36a and 36b; and a pair of guide members 38a and 38b upstanding from the body portion adjacent side edges 36a and 36b, respectively. Preferably, body portion is defined by upper and lower panel portions 40 and 42 having generally planer forwardly facing or front surfaces 40a and 42a with surface 40a being inclined rearwardly relative to surface 42a generally along a line or bend area 44 extending transversely between side edges 36a and 36b in alignment with guide members 38a and 38b.

In that guide members 38a and 38b are of like construction, only guide member 38a will be specifically described with like parts of guide member 38b being designated by like numerals bearing a "b" suffix.

Guide member 38a is best shown in FIGS. 5 and 6 as including a forwardly projecting or leading guide portion 46a and a rearwardly projecting or trailing guide portion 48a. Leading guide portion 46a is bounded by upper and lower edge portions 50a and 52a, which are arranged to converge in a direction extending towards drawer front end or end wall 16 and preferably joined by a rounded front end edge portion 54a.

Trailing guide portion 48a is bounded by upper and lower edge portions 56a and 58a, which are arranged to converge in a direction extending towards drawer rear end or end wall 18 and preferably joined by a squared off rear end edge portion 60a. Upper edge portions 50a and 56a are joined by an upper intermediate, rounded edge portion 62a, and lower edge portions 52a and 58a are joined by a lower, intermediate rounded edge portion 64a.

It will be understood that after mounting of follower 12 within drawer 10 in the manner to be described, body portion 34 extends transversely within the drawer between side walls 14a and 14b with panel surfaces 44a and 46a arranged to face relatively towards drawer front end wall 16 and guide members 38a and 38b slidably received within

guide channels **22a** and **22b**, respectively. When so positioned, items such as files, not shown, stored within file drawer **10** intermediate follower **12** and front end wall **16** and in engagement with the follower, and particularly with front surface **42a** of lower panel **42**, tend to tilt the follower forwardly towards a maximum forward tilted position shown in FIG. **6**, which is defined by engagement of lower edge portions of leading guide portions **46a** and **46b** with guide channel guide surfaces **30a** and **30b**, respectively, and by engagement of upper edge portions of trailing guide portions **48a** and **48b** with guide channel guide surfaces **28a** and **28b**, respectively.

Follower **12** may also be tilted rearwardly towards a maximum rearward tilted position, not shown, which may be defined by engagement of the upper edge portions of leading guide portions **46a** and **46b** with guide channel surfaces **28a** and **28b**, respectively, and by engagement of the lower edge portions of trailing guide portions **48a** and **48b** with guide channel guide surfaces **30a** and **30b**, respectively.

Reference is now made to FIGS. **3-6**, wherein file drawer side wall **14a** is shown as being formed with a through opening **70**, which is arranged in alignment with connecting surface **32a** of guide channel **22a** and sized to permit at least a portion of guide member **38a** to project outwardly there-through to a degree sufficient to accommodate for installation of follower **12** within file drawer **10** in the manner to be described. Opening **70** preferably corresponds in shape to leading guide portion **46a** and is formed with upper and lower edge portions **72** and **74**, which are arranged to converge in a direction extending towards drawer front end **16**. The front and rear ends of edge portions **72** and **74** are joined by a rounded front edge portion **76** and a straight rear edge portion **78**. It is preferable to arrange opening **70** such that upper edge portion **72** is arranged between the position shown in FIGS. **5** and **6**, wherein it forms a relatively small acute angle relative to guide surface **28a** on the order of about 15 degrees and a position in which it is disposed essentially parallel to such upper guide surface.

Follower **12** is installed within drawer **10** by manually inserting the follower downwardly into the drawer between side walls **14a** and **14b**, while the follower is arranged intermediate its maximum forward and rearward tilted positions with body portion **34** disposed at an angle on the order of about 45° degrees relative to the side walls; with panel front surfaces **40a** and **42a** arranged to face generally towards drawer front wall **16**, and with guide members **38a** and **38b** disposed in vertical alignment with and relatively adjacent guide channels **22a** and **22b**. Follower **12** is then tilted and moved lengthwise within the drawer as required to position leading guide portion **46a** of guide member **38a** in alignment with through opening **70** to permit the follower to be twisted about a line extending vertically through drawer bottom wall **20** to cause the leading guide portion to move outwardly of the drawer through the opening to assume a starting position. In this starting position, leading guide portion **46a** projects outwardly through opening **70** and trailing guide portion **48b** projects into guide channel **22b** with sufficient clearance to permit subsequent manual twisting of follower **12** relative to drawer **10** to assume an installed position, wherein body portion **34** is disposed normal or extends transversely of side walls **14a** and **14b** and guide members **38a** and **38b** are positioned essentially parallel to connecting surfaces **32a** and **32b** and for sliding movement lengthwise within guide channels **22a** and **22b**.

After follower **12** is arranged in its installed position, it can be moved lengthwise of drawer **10** and tilted relative thereto between its maximum rearward and forward tilted

positions. The positioning of opening **70** with its upper edge portion **72** arranged as shown in FIGS. **5** and **6** serves to prevent movement of follower **12** between its installed and starting position for all positions of the follower except when same is intentionally pivoted rearwardly into its rearward tilted position shown in FIG. **5**. For all other positions of follower **12**, guide member **38a** may be moved within guide channel **22a** past opening **70** without such opening interfering with sliding movement of such guide member or permitting unintended disassembly of the follower relative to drawer **10**.

What is claimed is:

1. In the combination of a file drawer provided with a pair of spaced-apart vertical side walls having guide channels extending lengthwise thereof intermediate front and rear ends of said file drawer; and a follower having a body portion sized to be received within said file drawer with a pair of spaced side edges thereof arranged adjacent said side walls and a pair of guide members upstanding from said body portion adjacent said side edges and sized and arranged for receipt within said guide channels and for movement lengthwise thereof, the improvement comprising in combination:

a mounting opening extending through one of said side walls in alignment with said guide channel thereof, said opening being sized to permit at least a portion of one of guide members to project outwardly there-through to a degree sufficient to accommodate installation of said follower within said file drawer by inserting said follower into said file drawer to assume a starting position with said body portion arranged at an angle of other than 90° relative to said side walls and said portion of said one guide member arranged to project outwardly through said opening and then twisting said follower to assume an installed position with said body portion arranged at an angle of approximately 90° relative to said side walls and said guide members positioned within said guide channels, each of said guide members includes leading and trailing guide portions projecting in opposite directions normal to said body portion relatively towards said front and rear ends, respectively, said portion of one of said guide members is said leading guide portion of said one guide member and projects outwardly through said opening and said trailing guide portion of the other of said guide members projects into the guide channel of the other of the side walls when in said starting position,

said opening corresponds in shape to said leading guide portion of said one guide member, said guide channels have upper and lower lengthwise extending guide surfaces, said leading and trailing guide portions each define downwardly and upwardly facing edge portions arranged to removably engage with said lower and upper guide surfaces of said guide channels, said downwardly and upwardly facing edge portions of said leading and trailing guide portions engaging with said lower and upper guide surfaces, respectively, to limit the extend of forwardly tilting movement of said follower within said file drawer to define a maximum forward tilted position, said upwardly and downwardly facing edge portions of said leading and trailing guide portions engaging with said upper and lower guide surfaces, respectively, to limit the extend of rearwardly tilting movement of said follower within said file drawer to define a maximum rearward tilted position, wherein items stored within said file drawer intermediate said follower and said front end of said file drawer

5

in engagement with said body portion tend to tilt said follower to assume said maximum forward tilted position, and said leading guide portion of said one guide member is tilted from alignment with said opening when said follower is in said forward tilted position, so as to prevent twisting of said follower from said installed position into said starting position.

2. The combination according to claim 1, wherein said leading edge portion of said one guide member is aligned with said opening when said follower is relatively adjacent said maximum rearward tilted position.

3. In the combination of a file drawer provided with a pair of spaced-apart vertical side walls having guide channels extending lengthwise thereof intermediate front and rear ends of said file drawer; and a follower having a body portion sized to be received within said file drawer with a pair of spaced side edges thereof arranged adjacent said side walls and a pair of guide members upstanding from said body portion adjacent said side edges and sized and arranged for receipt within said guide channels and for movement lengthwise thereof, the improvement comprising in combination:

a mounting opening extending through one of said side walls in alignment with said guide channel thereof, said opening being sized to permit at least a portion of one of guide members to project outwardly therethrough to a degree sufficient to accommodate installation of said follower within said file drawer by inserting said follower into said file drawer to assume a starting position with said body portion arranged at an angle of other than 90° relative to said side walls and said portion of said one guide member arranged to project outwardly through said opening and then twisting said follower to assume an installed position with said body portion arranged at an angle of approximately 90° relative to said side walls and said guide members positioned within said guide channels, each of said guide members includes leading and trailing guide portions projecting in opposite directions normal to said body portion relatively towards said front and rear ends, respectively, said portion of one of said guide members is said leading guide portion of said one guide member and projects outwardly through said opening and said trailing guide portion of the other of said guide members projects into the guide channel of the other of the side walls when in said starting position,

said opening corresponds in shape to said leading guide portion of said one guide member, said guide members engage with said guide channels alternatively to define forward and rearward tilted positions of said follower within said file drawer, wherein items stored within said file drawer intermediate said follower and said front end in engagement with said body portion tend to tilt said follower to assume said forward tilted position, and said portion of said one guide member is misaligned with said opening when said follower is in said forward tilted position, so as to prevent twisting of said follower from said installed position into said starting position.

4. In the combination of a file drawer provided with a pair of spaced-apart vertical side walls having guide channels extending lengthwise thereof intermediate front and rear ends of said file drawer; and a follower having a body portion sized to be received within said file drawer with a pair of spaced side edges thereof arranged adjacent said side walls and a pair of guide members upstanding from said body portion adjacent said side edges and sized and arranged

6

for receipt within said guide channels and for movement lengthwise thereof, the improvement comprising in combination:

a mounting opening extending through one of said side walls in alignment with said guide channel thereof, said opening being sized to permit at least a portion of one of guide members to project outwardly therethrough to a degree sufficient to accommodate installation of said follower within said file drawer by inserting said follower into said file drawer to assume a starting position with said body portion arranged at an angle of other than 90° relative to said side walls and said portion of said one guide member arranged to project outwardly through said opening and then twisting said follower to assume an installed position with said body portion arranged at an angle of approximately 90° relative to said side walls and said guide members positioned within said guide channels, each of said guide members includes leading and trailing guide portions projecting in opposite directions normal to said body portion relatively towards said front and rear ends, respectively, said portion of one of said guide members is said leading guide portion of said one guide member and projects outwardly through said opening and said trailing guide portion of the other of said guide members projects into the guide channel of the other of the side walls when in said starting position,

said opening corresponds in shape to said leading guide portion of said one guide member, said portion of said one guide member and said opening have upper and lower edge portions arranged to converge in a direction extending towards said front end of said file drawer, said guide channels have upper and lower guide surfaces engageable with said guide members and permitting tilting movement of said follower within said file drawer between forward and rearward tilted positions, items stored within said file drawer intermediate said follower and said front end and in engagement with said body portion tending to tilt said follower towards said forward tilted position, said upper and lower edge portions of said portion of said one guide member are disposed out of alignment with said upper and lower edge portions of said opening when said follower is in said forward tilted position.

5. The improvement according to claim 4, wherein said upper edge portion of said opening forms an acute angle with said upper guide surfaces of said guide channels equal to or less than about 15°.

6. In the combination of a file drawer provided with a pair of spaced-apart vertical side walls having guide channels extending lengthwise thereof intermediate front and rear ends of said file drawer; and a follower having a body portion sized to be received within said file drawer with a pair of spaced side edges thereof arranged adjacent said side walls and a pair of guide members upstanding from said body portion adjacent said side edges and sized and arranged for receipt within said guide channels and for movement lengthwise thereof, said guide members engage with said guide channels to define a forward tilted position of said follower within said file drawer, wherein items stored within said file drawer intermediate said follower and said front end in engagement with said body portion tend to tilt said follower to assume said forward tilted position, the improvement comprising in combination:

a mounting opening means extending through one of said side walls in alignment with said guide channel thereof, said opening means being sized and arranged to permit

7

at least a portion of one of guide members to be projected outwardly therethrough when said follower is disposed in a rearwardly tilted position to permit removable insertion of said follower within said file drawer, and said portion of said one guide member is misaligned with said opening means when said follower is in said forward tilted position, so as to prevent removal of said follower from said file drawer when said follower is disposed in said forward tilted position.

7. The improvement according to claim 6, wherein said portion of said one guide member and said opening means

8

have upper and lower edge portions arranged to converge in a direction extending towards said front end of said file drawer.

8. The combination according to claim 6, wherein each of said guide members includes leading and trailing guide portions projecting in opposite directions normal to said body portion relatively towards said front and rear ends, respectively, said portion of said one guide member is said leading guide portion of said one guide member, and said opening means corresponds in shape to said leading guide portion of said one guide member.

* * * * *