



US006965356B2

(12) **United States Patent**
Vaccarelli

(10) **Patent No.:** **US 6,965,356 B2**

(45) **Date of Patent:** ***Nov. 15, 2005**

(54) **MICROSCOPY LABORATORY SYSTEM**

(75) Inventor: **Vincent Vaccarelli**, Getzville, NY (US)

(73) Assignee: **Leica Microsystems Inc.**, Depew, NY (US)

(*) Notice: Subject to any disclaimer, the term of this patent is extended or adjusted under 35 U.S.C. 154(b) by 0 days.

This patent is subject to a terminal disclaimer.

(21) Appl. No.: **10/109,376**

(22) Filed: **Mar. 28, 2002**

(65) **Prior Publication Data**

US 2002/0154105 A1 Oct. 24, 2002

Related U.S. Application Data

(63) Continuation-in-part of application No. 09/821,578, filed on Mar. 29, 2001, now Pat. No. 6,900,776.

(51) **Int. Cl.⁷** **G09G 5/00**

(52) **U.S. Cl.** **345/2.2**

(58) **Field of Search** 434/350, 351, 434/362, 432, 433; 359/368, 363; 382/128; 348/79, 80; 396/432; D16/131; 345/173, 345/1.2, 1.3, 2.1, 2.2

(56) **References Cited**

U.S. PATENT DOCUMENTS

4,202,037 A * 5/1980 Glaser et al. 382/128
5,376,007 A * 12/1994 Zirm 434/262
5,484,293 A 1/1996 Ford et al. 434/432

5,793,969 A * 8/1998 Kamentsky et al. 359/363
6,147,797 A * 11/2000 Lee 359/363
6,155,840 A * 12/2000 Sallette 434/323
6,476,858 B1 * 11/2002 Ramirez Diaz et al. 348/159
6,628,918 B2 * 9/2003 Roschelle et al. 434/350

FOREIGN PATENT DOCUMENTS

GB 2220828 A 1/1990
WO WO97/37494 10/1997

OTHER PUBLICATIONS

“General Presentations, Training, and Collaborative Planning.” http://www.boeckeler.com/pointmaker/slide_shows/general, Jan. 24, 2000, Oct. 22, 2003.

* cited by examiner

Primary Examiner—Chanh Nguyen

(74) *Attorney, Agent, or Firm*—Simpson & Simpson, PLLC

(57) **ABSTRACT**

A microscopy laboratory system for efficient instruction is disclosed. The system comprises a plurality of student microscopes each equipped with a camera for generating an image signal representing a student view image of at least a portion of the field of view of the student microscope, multiplexed control means connected by video cables or wireless technology to the cameras to provide a composite instruction image signal based on student view images from one or more selected microscopes, and a projection unit or other public display for presenting the instruction image to the students in the laboratory. An instructor microscope can also be coupled into the system, and a display image marker is preferably linked to the multiplexed control means for inserting instructor annotations into the displayed instruction image.

19 Claims, 7 Drawing Sheets

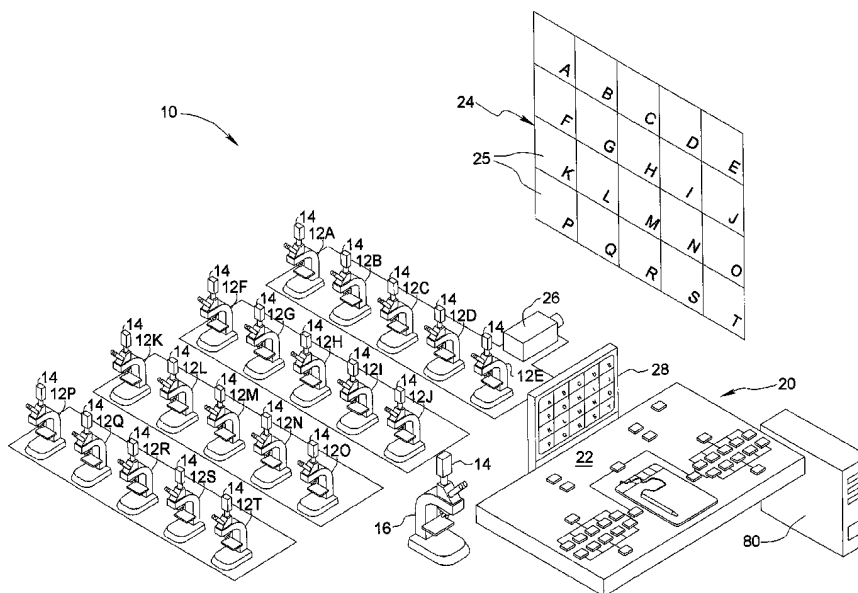

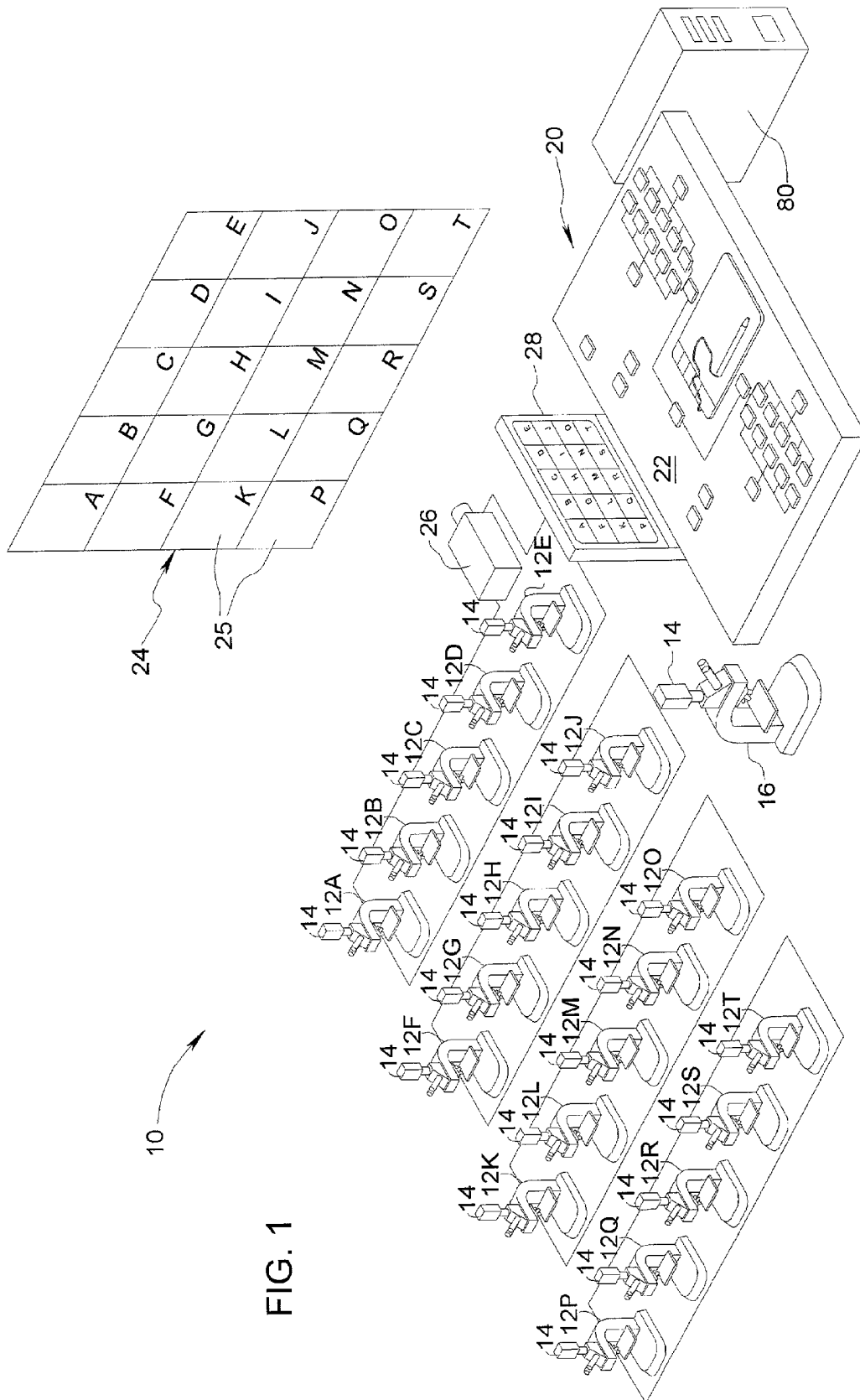

FIG. 1

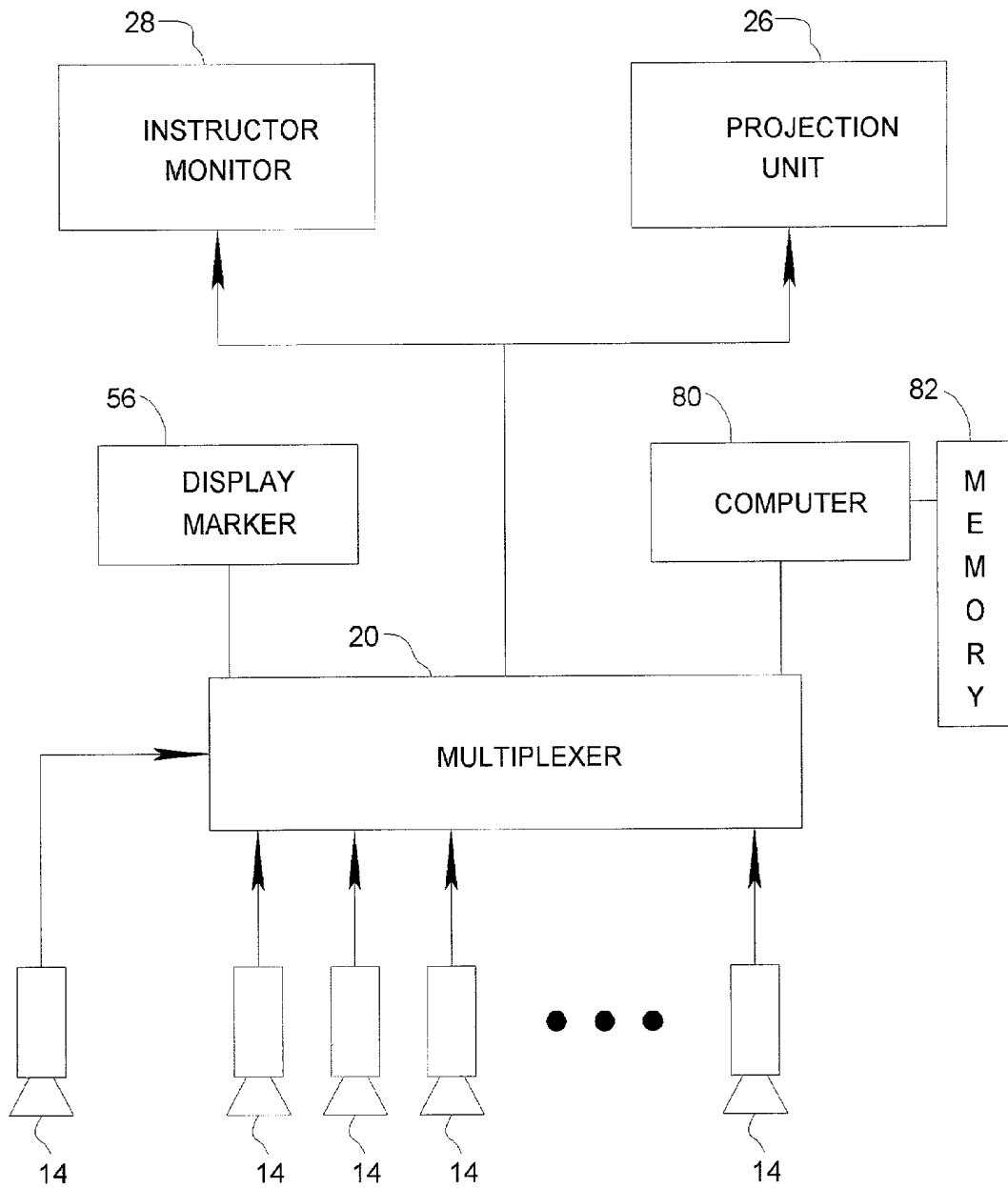

FIG. 2

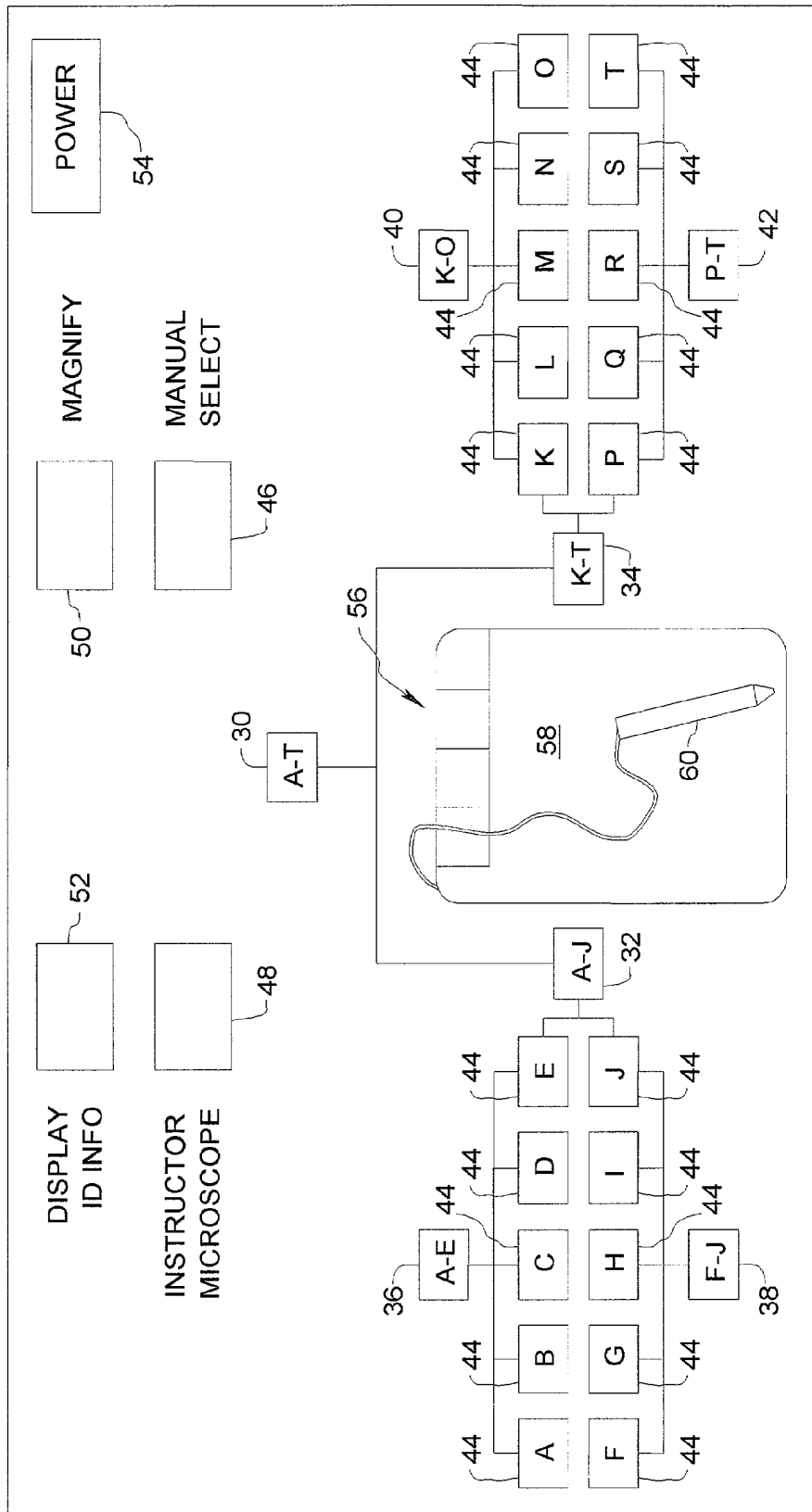

FIG. 3

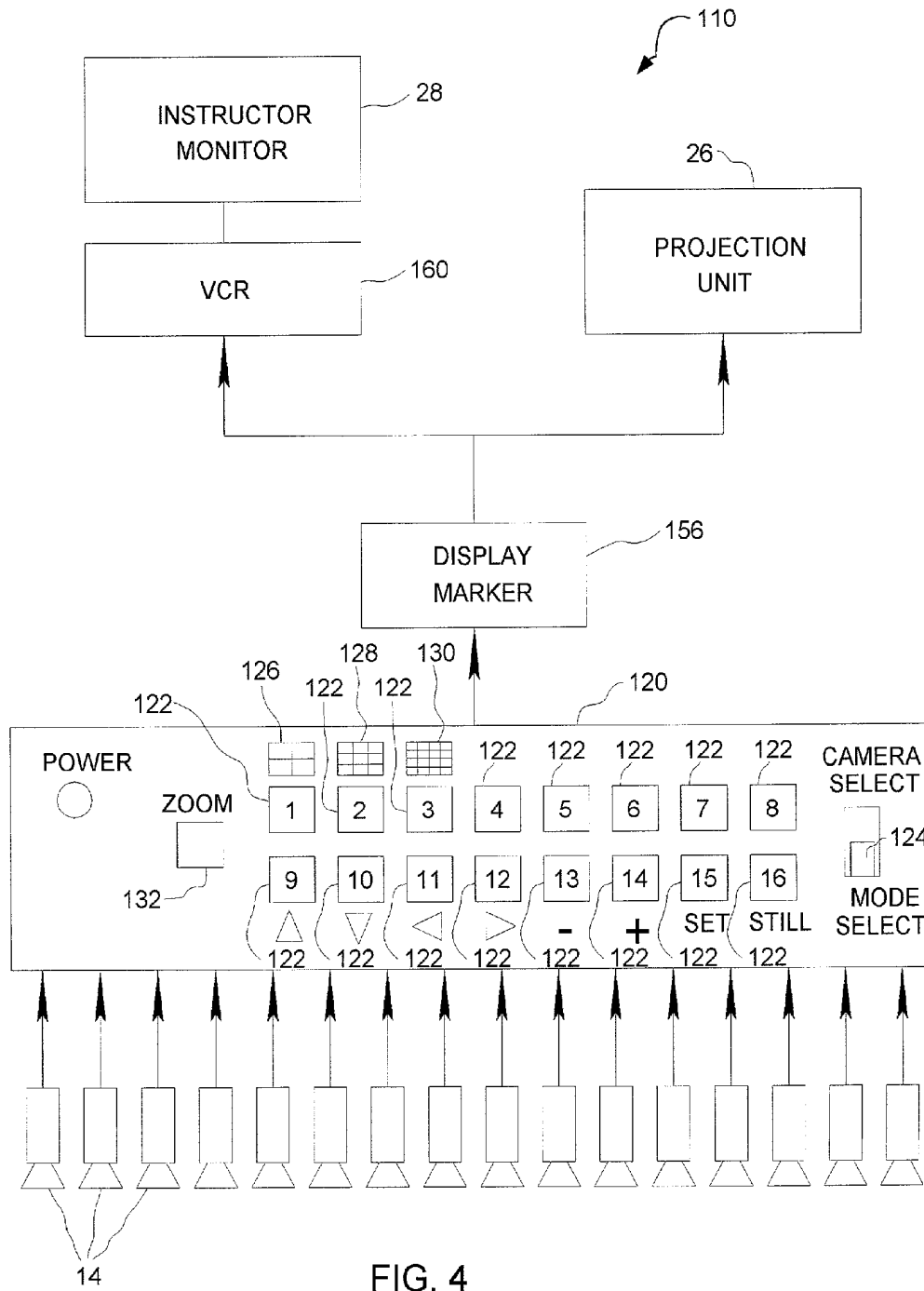

FIG. 4

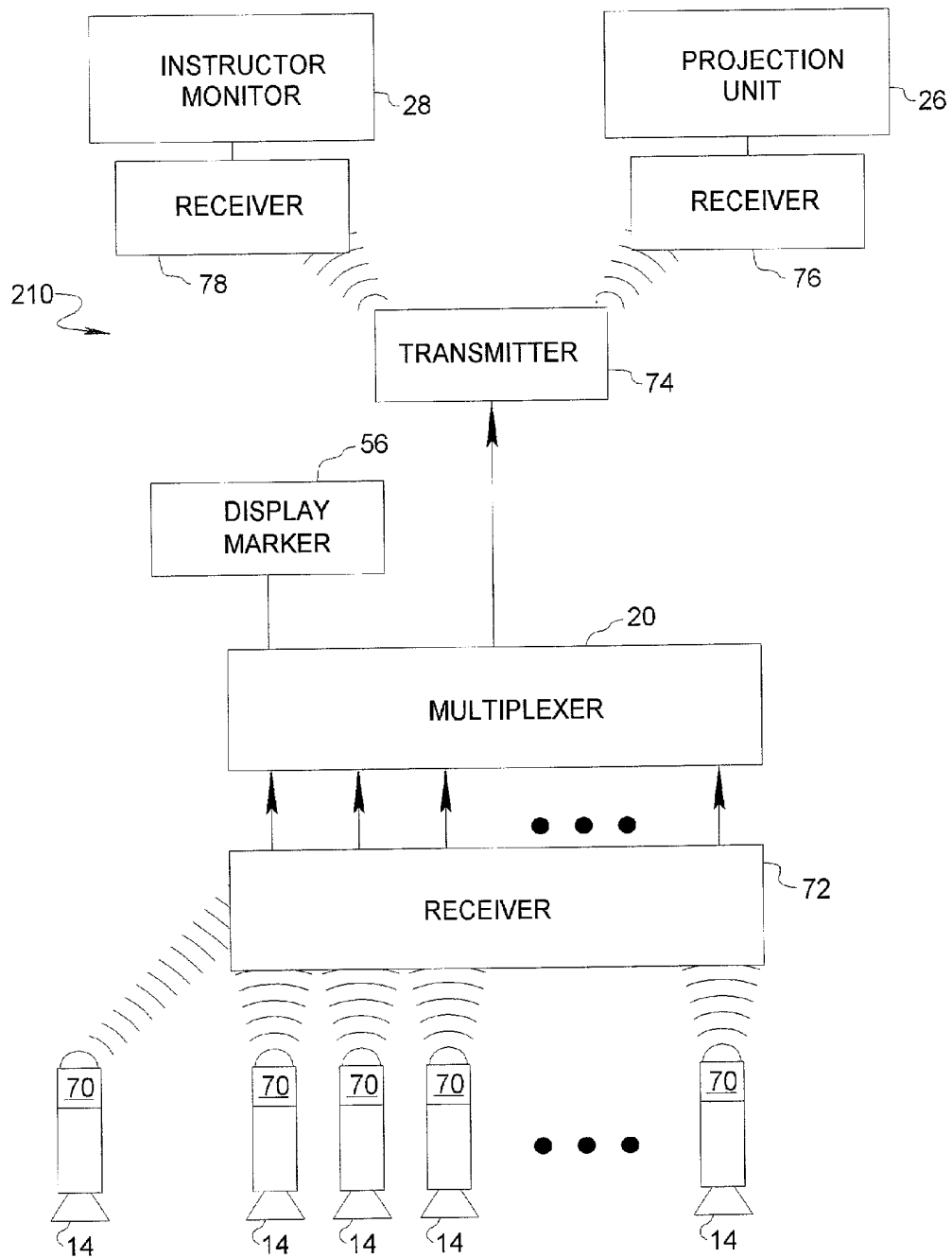

FIG. 5

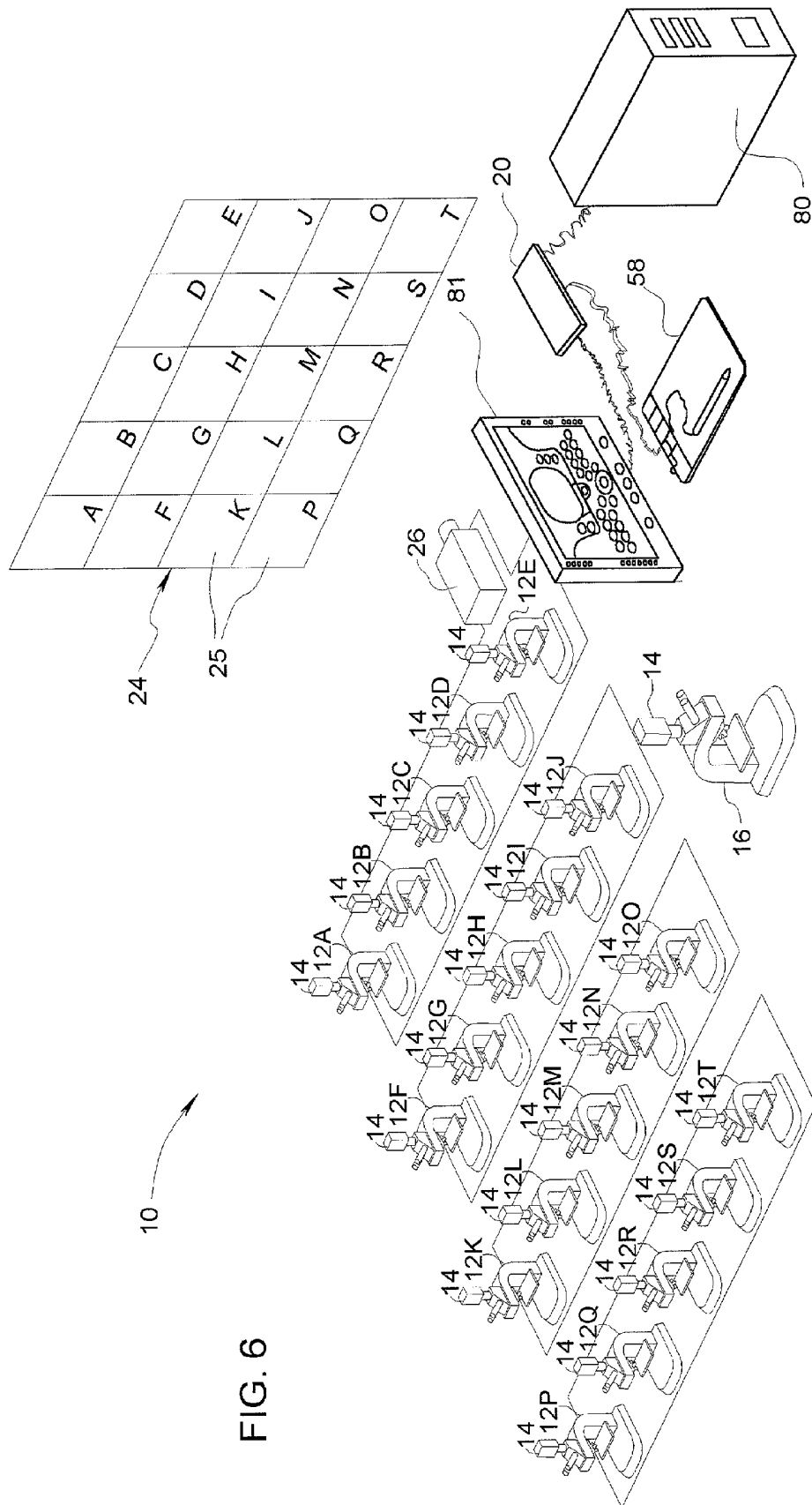
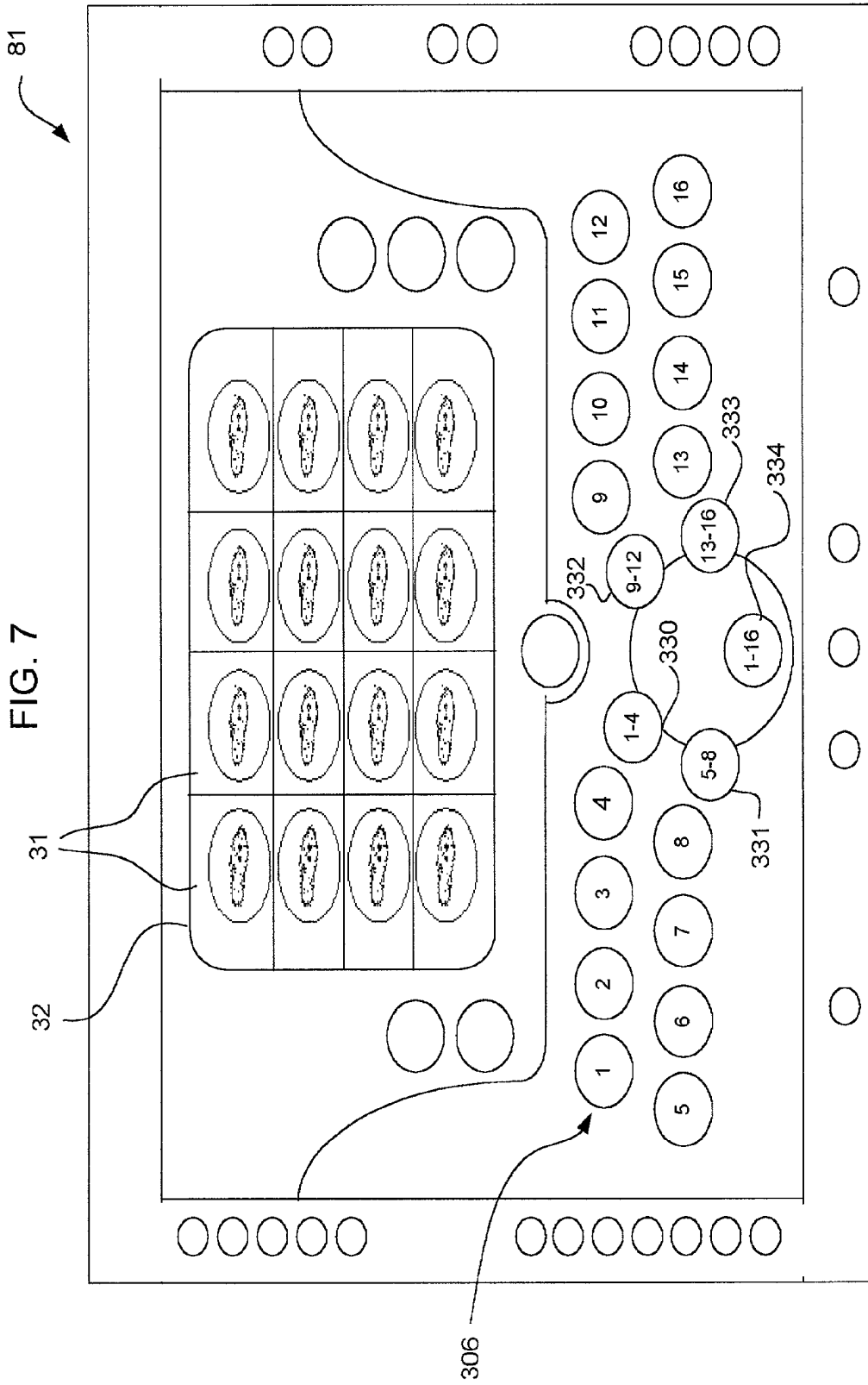

FIG. 6

FIG. 7



1

MICROSCOPY LABORATORY SYSTEM**CROSS-REFERENCE TO RELATED APPLICATIONS**

The instant application is a continuation-in-part of U.S. Ser. No. 09/821,578, filed Mar. 29, 2001 now U.S. Pat. No. 6,900,776.

BACKGROUND OF THE INVENTION

The present invention relates generally to instructional settings wherein participants view specimens through respective microscopes, and more particularly to a microscopy laboratory system wherein an instructor and students can view an overall instructional image that selectively includes images from the field of view of one, some, or all of the microscopes in the laboratory.

Microscopy laboratories at universities, teaching hospitals, etc. are known to include a television monitor or projection unit that receives an image signal from a camera mounted on the instructor's microscope, such as by a C-mount, trinocular viewing body, video module, or the like. In this way, each student in the laboratory can view an image that serves as a model to help him or her position a like specimen on his or her own microscope and to adjust the specimen location, objective power, focus, illumination, filters and other parameters of the microscope in an effort to match the displayed image from the field of view of the instructor's microscope. In this type of system, it is also known to provide a marking device that allows the instructor to annotate the displayed image from his or her microscope. Absent this technology, a photograph in a textbook is often used as a model. A drawback of this system is that the instructor cannot see what the students are viewing through their own microscopes. Often, the instructor must walk around the laboratory and look through each student's microscope to make sure every student in the laboratory is viewing a proper image, or the instructor must walk over to a particular student's station whenever a question arises. Clearly, this type of system is inefficient because the instructor must spend time checking the student microscopes rather than instructing the students. Another drawback is that the instructor has no means to annotate an image from a student's microscope to better provide constructive criticism or positive reinforcement.

BRIEF SUMMARY OF THE INVENTION

Therefore, it is an object of the present invention to provide an improved microscopy laboratory system that allows an instructor and students to simultaneously see images from the field of view of one, some, or all of the student microscopes as desired.

It is another object of the present invention to provide an improved microscopy laboratory system that allows an instructor to annotate images from the field of view of the instructor's microscope and any student's microscope for instructional purposes.

These and other objects are achieved by a microscopy laboratory system according to the present invention. The system comprises a plurality of student microscopes each having a camera, for example a digital video camera, coupled thereto for generating an image signal representing a student view image of at least a portion of the field of view of the student microscope. The system also comprises multiplexed control means connected by video cables or wire-

2

less technology to the cameras to receive the respective image signals, and a display means such as a projection unit, one or more shared viewing monitors, or individual student viewing monitors connected to the multiplexed control means for presenting an instruction image to the students in the laboratory. The multiplexed control means enables an instructor to select a set of image signals that will make up the publicly displayed instruction image. Where more than one image signal is selected, the instruction image is divided into smaller image windows corresponding to the selected image signals. The selected set of image signals can be a set of one image signal, a set of image signals corresponding to one of a plurality of predefined sub-groups of image signals, a sub-group of image signals chosen by the instructor, or a set of all the available image signals.

The microscopy laboratory system preferably comprises an instructor microscope equipped with a camera that is also connected to supply an image signal to the multiplexed control means, whereby the instruction image can include an instructor view image. A dedicated instructor monitor is preferably provided for presenting the instruction image to the instructor. This dedicated instructor monitor may comprise a cathode ray tube, a liquid crystal display (LCD), or a touch-screen. The system also preferably comprises a display image marker connected to the multiplexed control means for enabling the instructor to annotate the instruction image seen by the students, and a computer linked to the multiplexed control means for storage, retrieval, and enhancement of images.

BRIEF DESCRIPTION OF THE SEVERAL VIEWS OF THE DRAWINGS

The nature and mode of operation of the present invention will now be more fully described in the following detailed description of the invention taken with the accompanying drawing figures, in which:

FIG. 1 is a general schematic view of a microscopy laboratory system formed in accordance with an embodiment of the present invention;

FIG. 2 is a block diagram showing connections between hardware components of the microscopy laboratory system shown in FIG. 1;

FIG. 3 is a plan view of a user interface of a multiplexer control means of the embodiment shown in FIG. 1;

FIG. 4 is schematic diagram of a microscopy laboratory system formed in accordance with another embodiment of the present invention utilizing a commercially available multiplexer;

FIG. 5 is a schematic diagram of a microscopy laboratory system formed in accordance with another embodiment of the present invention utilizing wireless signal communication;

FIG. 6 is a view similar to that of FIG. 1 illustrating a second embodiment of the present invention which utilizes a touch screen interface and display; and,

FIG. 7 is a view of a typical touch screen of the second embodiment.

DETAILED DESCRIPTION OF THE INVENTION

Referring initially to FIGS. 1 and 2 of the drawings, a microscopy laboratory system formed in accordance with a first embodiment of the present invention is generally identified by reference numeral 10. Microscopy laboratory system 10 comprises a plurality of student microscopes

3

12A–12T each equipped with a video camera 14 for generating an image signal representing a student view image of at least a portion of the field of view of the corresponding student microscope, and an instructor microscope 16 likewise equipped with a camera 14 for generating an image signal representing an instructor view image of at least a portion of the field of view of instructor microscope 16. Cameras 14 are preferably video cameras that are either retro-fitted to or integrated with the microscope through a C-mount, a trinocular viewing body attachment, or an integrated video module inserted between the microscope stand and the binocular tube of the microscope. By way of non-limiting example, the Leica ICA and Leica ICCA video modules available from Leica Microsystems Inc. are suitable for practicing the present invention with various specified microscope models available from the same supplier.

Microscopy laboratory system 10 further comprises multiplexed control means 20 connected to cameras 14 for receiving image signals as input, enabling an instructor to select a set of the received image signals for display as output, and generating an instruction image signal based on the selected set of image signals. In the embodiment of FIGS. 1 and 2, multiplexed control means 20 is a video multiplexer configured with a custom user interface 22, for example a user interface as shown in FIG. 3, that allows the instructor to establish a suitable instruction image 24 as will be described below. Multiplexed control means 20 could also be a digital image multiplexer, depending on the format of the image signals from cameras 14. Multiplexed control means 20 can multiplex the images for display on local display means 28 as shown in FIG. 1, or for display by touch screen 81 as shown in FIGS. 6–7.

The instruction image signal from multiplexed control means 20 is communicated to a suitable public display device, such as a projection unit 26 connected to the multiplexed control means, so that all students can simultaneously view instruction image 24. As an alternative to projecting instruction image 24 for public viewing, it is of course possible to provide one or several shared viewing monitors, and it is also possible to provide each student microscope station with its own viewing means, such as a small video monitor or display unit (not shown) connected to receive output from multiplexed control means 20. An instructor monitor 28, shown in FIG. 1, or touch screen 81, shown in FIGS. 6 and 7, is preferably provided in the vicinity of user interface 22 for facilitating ergonomically agreeable viewing of instruction image 24 by the instructor.

Adverting now to the first embodiment shown in FIGS. 1–5, user interface 22 shown in FIG. 3 generally comprises a bracketed button system that enables the instructor to compose a suitable instruction image 24 by choosing a set of image signals corresponding to view images which the instructor wishes to include in the instruction image. Selection of button 30 results in an instruction image 24 like that illustrated in FIG. 1, in which the instruction image is divided into a plurality of smaller image windows 25 such that all of the student view images from student microscopes 12A–12T are presented in the instruction image. Selection of button 32 yields an instruction image containing only student view images from student microscopes 12A–12J, while selection of button 34 yields an instruction image containing only student view images from student microscopes 12K–12T. Instruction image 24 can be restricted to further sub-groups of student view images by selection of button 36 corresponding to student microscopes 12A–12E, button 38 corresponding to student microscopes 12F–12J, button 40 corresponding to student microscopes 12K–12O, or button

4

42 corresponding to student microscopes 12P–12T. Instruction image 24 can also be limited to a single student view image from a chosen student microscope by pressing any one of buttons 44. A MANUAL SELECT button 46 is preferably provided to allow the instructor to compose an instruction image that differs from one of the predetermined sub-groups associated with buttons 32, 34, 36, 38, 40, and 42. With MANUAL SELECT button 46 depressed, the instructor can then select more than one button 44 to choose the desired student view images. The instructor may also present an instruction image corresponding to the image signal from instructor microscope 16 using INSTRUCTOR MICROSCOPE button 48. An image magnification function is preferably provided and is accessed through MAGNIFY button 50. If desired, identifying indicia 27 are superimposed in each image window 25 to indicate the particular microscope associated with the image window by pressing DISPLAY ID INFO button 52. User interface 22 is also shown as including a POWER button 54.

Microscopy laboratory system 10 further comprises a display image marker 56 connected to the multiplexed control means 20 for enabling the instructor to annotate instruction image 24, and a computer 80 having memory 82 also connected to the multiplexed control means for storing instruction image 24 and/or student view images from microscopes 14 and/or an instructor view image. Display image marker 56 can be a video marking system that takes input from a digitizing tablet 58 and accompanying pen 60, and/or from other input sources such as a keyboard, light pen, or touch screen, and superimposes markings on instruction image 24. Display image marker 56 can be integrated with multiplexed control means 20, as shown, or can be connected as a stand-alone portion of the system. As will be appreciated, display image marker 56 gives the instructor considerable power to highlight important image features to all students, highlight problems with a particular student view image, and emphasize positive aspects of a particular student view image. Computer 80 can be used to store images to and retrieve images from memory 82, and to enhance images using available software.

FIG. 4 shows an embodiment of the present invention wherein a microscopy laboratory system 110 is configured using an existing “off the shelf” video multiplexer 120. Video multiplexer 120 is a PANASONIC® WJ-FS216 Digital Video Simplex Multiplexer having sixteen camera inputs for receiving image signals from sixteen cameras 14, one camera being coupled with an instructor microscope and the remaining fifteen cameras being coupled with respective student microscopes. Buttons 122 on multiplexer 120 allow the image signal from a particular camera to be selected when toggle 124 is switched to a “CAMERA SELECT” position. Certain of the buttons 122 have a dual function that is enabled when toggle 124 is switched to a “MODE SELECT” position as shown in FIG. 4. More specifically, the buttons for the first through third cameras each have a second mode for providing a multi-window display of four, nine, and sixteen image windows, as indicated by icons 126, 128, and 130, respectively. A ZOOM button 132 for magnifying instruction image 24 is also provided.

Microscopy laboratory system 110 also includes a commercially available display image marker 156. The POINT-MAKER® PVI-44 Video Marker available from Boeckeler Instruments, Inc. is suitable for practicing the present invention. Display image marker 156 is connected by standard video cable to receive an output image signal from multiplexer 120. A final instruction image signal, including any annotations added by way of display image marker 156, is

5

supplied to projection unit 26 and to an optional videocassette recorder 160 operatively associated with instructor monitor 28. Consequently, it is possible to record instructional lessons and observed microscopic processes for future use.

The embodiments described above rely on video cables for transmitting image signals between components. In situations where extensive cabling is impractical, unsafe, or otherwise undesirable, it is contemplated to provide wireless connections enabling transmission of image signals from cameras 14 to multiplexed control means 20, and from multiplexed control means 20 to projection unit 26 or to individual or shared student viewing monitors. FIG. 5 shows a microscopy laboratory system 210 that is generally similar to systems 10 and 110 described above, however cameras 14 are equipped with transmitters 70 for transmitting the image signals to a multi-channel receiver 72 connected to multiplexed control means 20. In addition, a transmitter 74 is operatively connected to multiplexed control means 20 and communicates with corresponding receivers 76 and 78 linked to projection unit 26 and instructor monitor 28, respectively. Receivers 72, 76 and 78 and transmitters 70 and 74 can be analog wireless communication devices or digital wireless communication devices, depending upon system requirements.

A second embodiment of the invention is illustrated in FIGS. 6 and 7, respectively. This second embodiment is similar to the first embodiment, except user interface 22 and display 28 have been replaced by touch screen 81. As is well known, a touch screen is a display device that allows users to interact with a computer system by touching a particular area on the surface of the screen. Touch screen technology can be implemented by a number of different sensing techniques. Currently there are four different types of commercially available touch screen technologies: infrared, resistive membrane, capacitive, and surface acoustic wave. All of these are active technologies in that they rely on generating an active signal and observing the effect on the active signal of an object against the screen (e.g., a touching of the screen). In a preferred embodiment of the invention shown in FIGS. 6 and 7, a touch screen Model R-15 CT, available from Rosen Products LLC, 1020 Owen Loop South, Eugene, Oreg. 97402 was used, although it should be appreciated that other touch screens, using any of the commercially available technologies described above. For examples, touch screens described in U.S. Pat. Nos. 6,172,667 and 5,764,223, both incorporated herein by reference, would be suitable for use in the present invention.

In the touch screen embodiment shown, a plurality of images associated with microscopes 12A-12T can selectively appear on the touch screen display. The instructor can select which images to display both on touch screen 81 and on public display 24, by touch controls on the touch screen itself. The instructor can also annotate individual display images with digitizing pad 58. In a preferred embodiment, digitizing pad 58 is Model PVI-44, available from Boeckler Instruments, Inc., 4650 S. Butterfield Drive, Tucson, Ariz. 85714, although other similar devices would also be suitable.

Touch screen 81 is shown in more detail in FIG. 7. Screen 81 includes a display 32 upon which one or more microscope images 31 may be selected by the instructor and displayed. In FIG. 7, a plurality of images of a paramecium are displayed. The touch screen includes a number of control buttons, all controllable by touch. Button group 306, for example, comprises buttons labeled 1-16, respectively, which, when activated, cause a corresponding microscope

6

image to be displayed on display 32. For example, if button 14 is touched, the image from microscope 14 is displayed, etc. Similarly, sub-group buttons 330-334, respectively, activate and display images from groups of microscopes. For example, if button 333 is touched, images from microscopes 13-16 are displayed. Other buttons control other functions of the touch screen as is well known in the art. For example, some buttons control navigation through the various microscope images, others control zoom, field of view, display color, etc. The instructor can also annotate using either the digitizing pad or the touch screen. The instructor can also control what images are displayed on the public display and can obviously display the image from instructor's microscope 16.

Thus, it is seen that the objects of the present invention are efficiently attained, although changes and modifications to the invention should be readily apparent to those having ordinary skill in the art, and these changes and modifications are intended to be within the spirit and scope of the invention as claimed.

What is claimed is:

1. A microscopy laboratory system comprising:
 - a plurality of student microscopes;
 - a plurality of cameras associated one with each of said plurality of student microscopes for generating an image signal representing a student view image of at least a portion of the field of view of said student microscope;
 - multiplexed control means connected to said plurality of cameras for receiving said image signals and enabling an instructor to select a set of said image signals for display, wherein said multiplexed control means generates an instruction image signal generated from said selected set of image signals; and
 - a touch screen display means connected to said multiplexed control means for receiving said instruction image signal, displaying an instruction image comprising student view images corresponding to said selected set of image signals, and annotating said instruction image in real time.
2. The microscope laboratory system according to claim 1, further comprising an instructor microscope and a camera for generating an image signal representing an instructor view image of at least a portion of the field of view of said instructor microscope, wherein said multiplexed control means is connected to said camera associated with said instructor microscope to receive said image signal generated thereby, whereby said instruction image optionally comprises said instructor view image.
3. The microscopy laboratory system according to claim 2, wherein said multiplexed control means allows said instructor to select all of said image signals from said cameras associated with said plurality of student microscopes as said selected set.
4. The microscopy laboratory system according to claim 2, wherein said multiplexed control means allows said instructor to select said image signal from said camera associated with any one of said plurality of student microscopes as said selected set.
5. The microscopy laboratory system according to claim 2, wherein said multiplexed control means allows said instructor to select said image signals from cameras of a predetermined sub-group of said plurality of student microscopes as said selected set.
6. The microscopy laboratory system according to claim 5, wherein there is a plurality of different predetermined sub-groups of said student microscopes.

7

7. The microscopy laboratory system according to claim 2, wherein said multiplexed control means allows said instructor to select said image signal from said camera associated with said instructor microscope as said selected set.

8. The microscopy laboratory system according to claim 2, further comprising a computer connected to said multiplexed control means, said computer having a memory, whereby said instruction image, said student view images, and said instructor view image can be stored in, enhanced and retrieved from said memory.

9. The microscopy laboratory system according to claim 2, wherein said multiplexed control means comprises means for selectively superimposing respective identification information on each said student view image in said instruction image.

10. The microscopy laboratory system according to claim 1, wherein said multiplexed control means comprises means for magnifying said instruction image.

11. The microscopy laboratory system according to claim 2, wherein said multiplexed control means comprises means for magnifying said instruction image.

12. The microscopy laboratory system according to claim 1, wherein said multiplexed control means allows said instructor to select all of said image signals from said cameras associated with said plurality of student microscopes as said selected set.

13. The microscopy laboratory system according to claim 1, wherein said multiplexed control means allows said instructor to select said image signal from said camera associated with any one of said plurality of student microscopes as said selected set.

8

14. The microscopy laboratory system according to claim 1, wherein said multiplexed control means allows said instructor to select said image signals from cameras of a predetermined sub-group of said plurality of student microscopes as said selected set.

15. The microscopy laboratory system according to claim 14, wherein there is a plurality of different predetermined sub-groups of said student microscopes.

16. The microscopy laboratory system according to claim 1, further comprising a computer connected to said multiplexed control means, said computer having a memory, whereby said instruction image and said student view images can be stored in, enhanced and retrieved from said memory.

17. The microscopy laboratory system according to claim 1, wherein said multiplexed control means comprises means for selectively superimposing respective identification information on each said student view image in said instruction image.

18. The microscopy laboratory system according to claim 1, wherein said connection between said multiplexed control means and said plurality of cameras comprises a wireless connection.

19. The microscopy laboratory system according to claim 1, wherein said connection between said touch screen display means and said multiplexed control means comprises a wireless connection.

* * * * *