



US007375792B2

(12) **United States Patent**
Vollrath et al.

(10) **Patent No.:** **US 7,375,792 B2**
(45) **Date of Patent:** **May 20, 2008**

(54) **APPARATUS FOR MEASURING FEATURE WIDTHS ON MASKS FOR THE SEMICONDUCTOR INDUSTRY**

7,130,037 B1 * 10/2006 Lange 356/237.2
2003/0053037 A1 3/2003 Blaesing-Bangert et al. ... 355/53
2004/0065517 A1 * 4/2004 Watson et al. 188/378
2005/0052642 A1 * 3/2005 Shibata et al. 356/237.1

(75) Inventors: **Wolfgang Vollrath**, Burbach (DE);
Frank Hillmann, Deggendorf (DE);
Gerd Scheuring, Munich (DE);
Hans-Jürgen Brueck, Munich (DE)

FOREIGN PATENT DOCUMENTS

(73) Assignees: **Leica Microsystems Semiconductor GmbH**, Wetzlar (DE); **MueTec Automatisierte Mikroskopie und Messtechnik GmbH**, Munich (DE)

DE	2441336	3/1976
DE	206 607	2/1984
DE	221 563	4/1985
DE	101 40 174	3/2003
JP	56113115	9/1981

(*) Notice: Subject to any disclaimer, the term of this patent is extended or adjusted under 35 U.S.C. 154(b) by 628 days.

* cited by examiner

(21) Appl. No.: **10/711,424**

Primary Examiner—D. Rutledge

(22) Filed: **Sep. 17, 2004**

(74) *Attorney, Agent, or Firm*—Simpson & Simpson, PLLC

(65) **Prior Publication Data**

(57) **ABSTRACT**

US 2005/0084770 A1 Apr. 21, 2005

(51) **Int. Cl.**
G03B 27/42 (2006.01)

(52) **U.S. Cl.** **355/53; 355/77**

(58) **Field of Classification Search** **355/53, 355/67, 77**

See application file for complete search history.

An apparatus for measuring feature widths on masks 1 for the semiconductor industry is disclosed. The apparatus encompasses a carrier plate 16 that is retained in vibrationally decoupled fashion in a base frame 14; a scanning stage 18, arranged on the carrier plate 16, that carries a mask 1 to be measured, the mask 1 defining a surface 4; and an objective 2 arranged opposite the mask 1. A liquid 25 is provided between the objective 2 and the surface 4 of the mask 1.

(56) **References Cited**

U.S. PATENT DOCUMENTS

4,008,967 A 2/1977 Kiemle 356/239

22 Claims, 5 Drawing Sheets

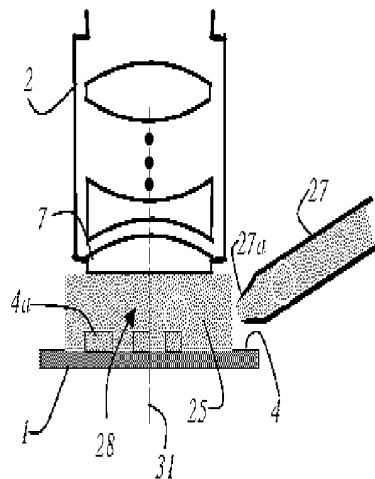
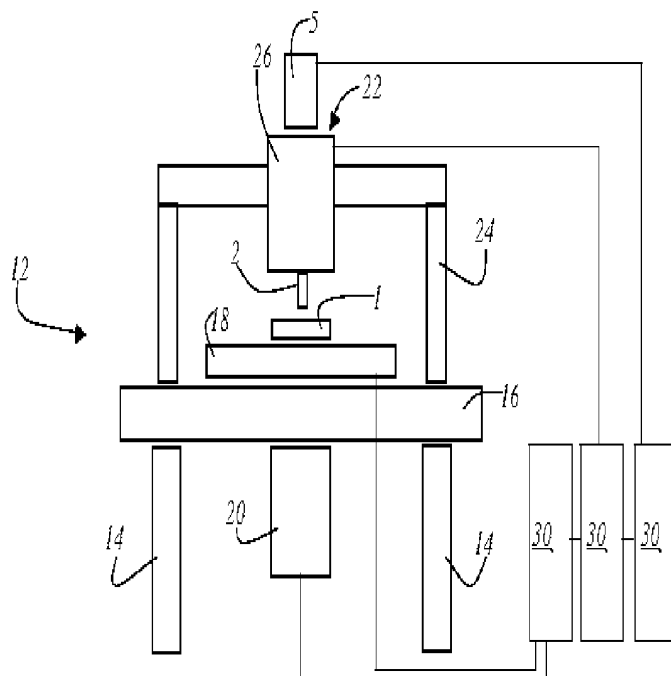

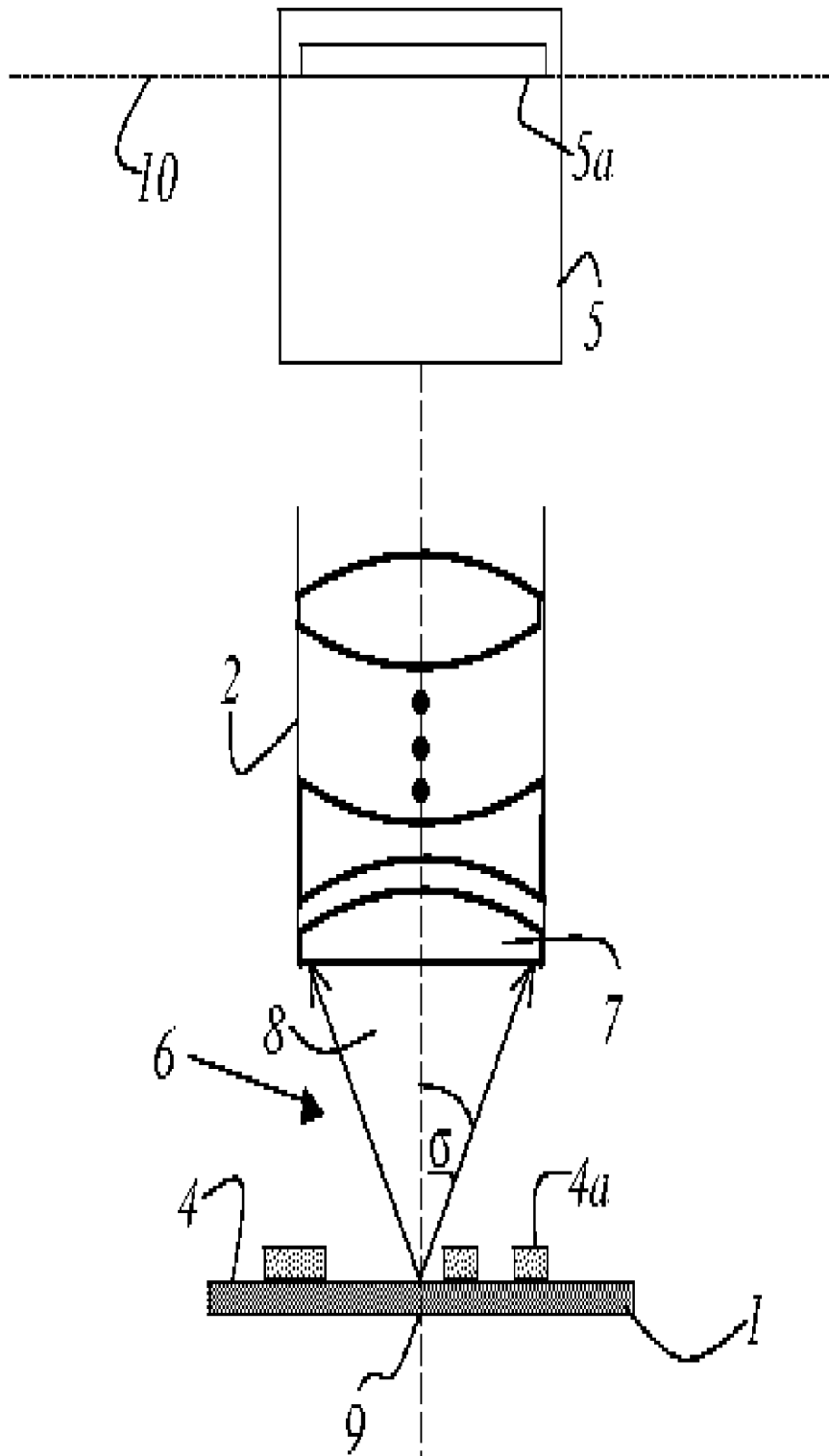

Prior Art

Fig. 1

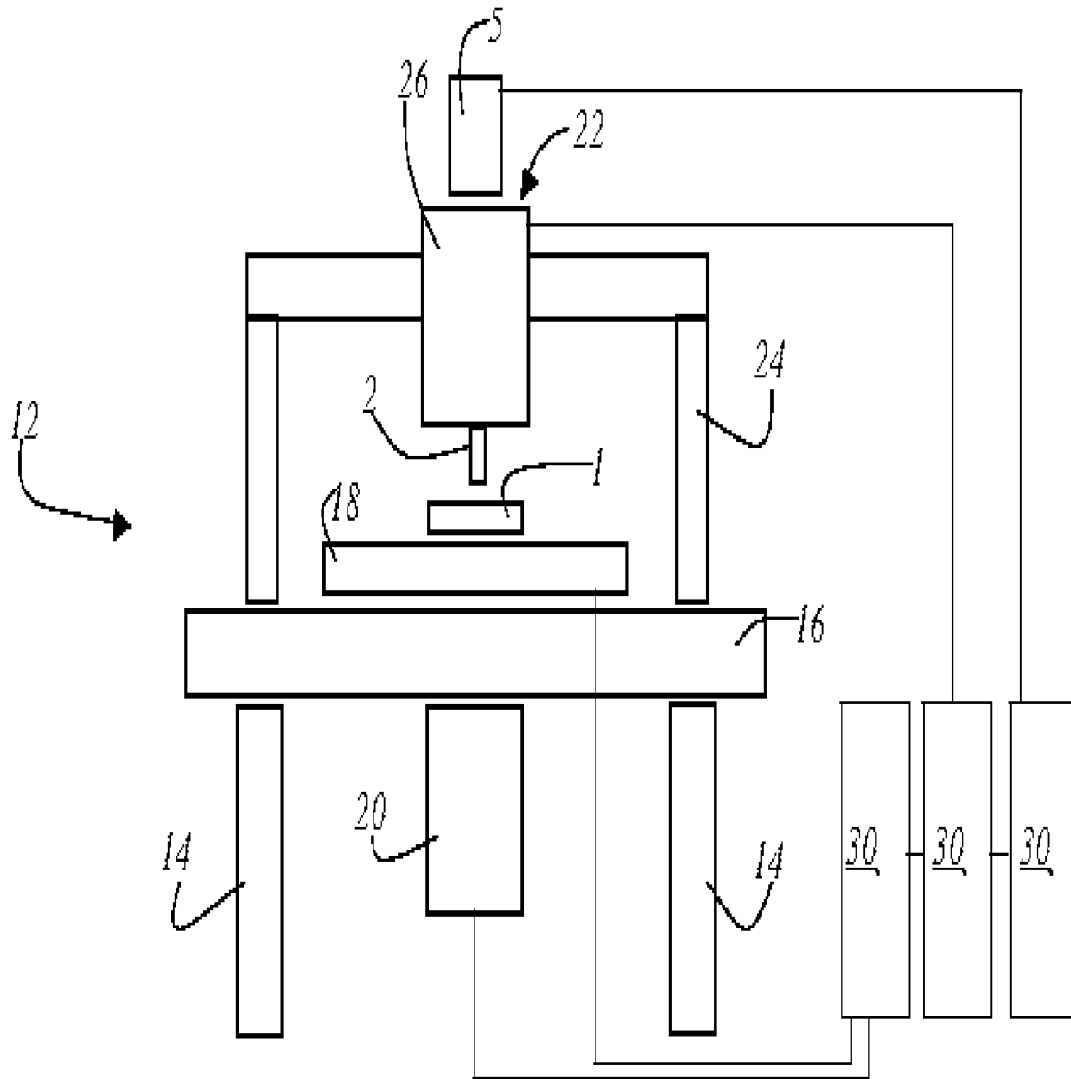

Fig. 2

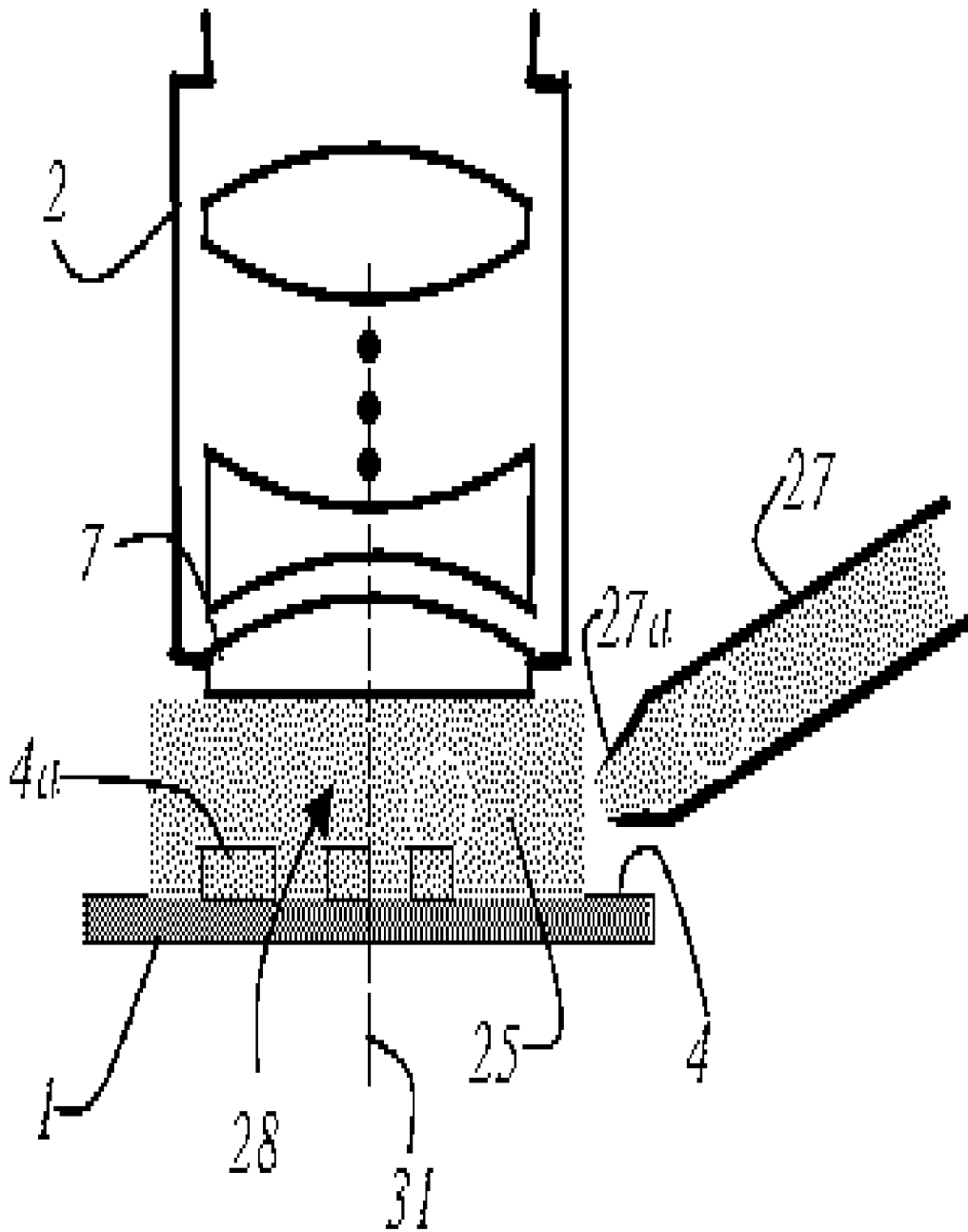

Fig. 3

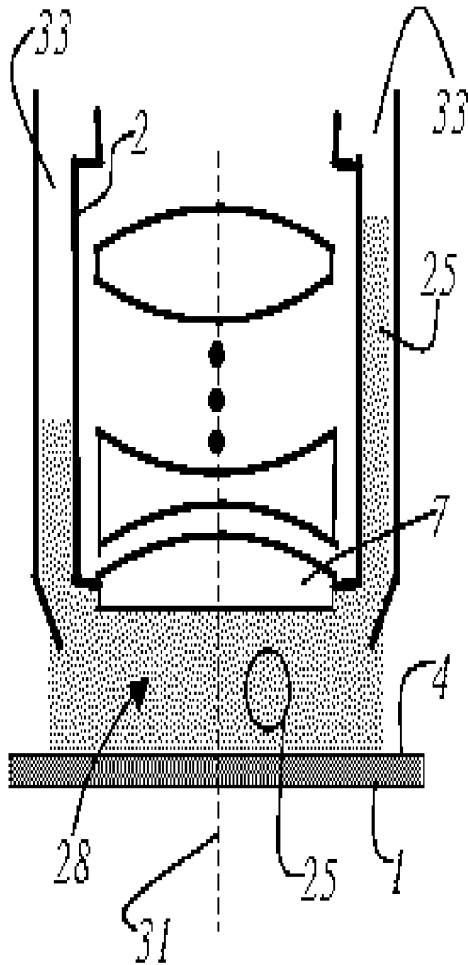

Fig. 4

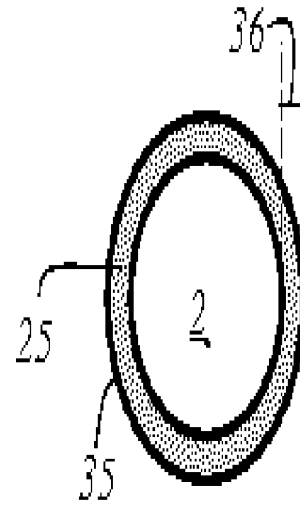

Fig. 5a

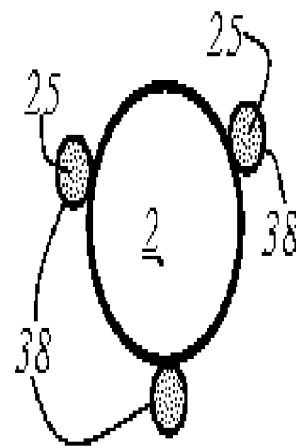

Fig. 5b

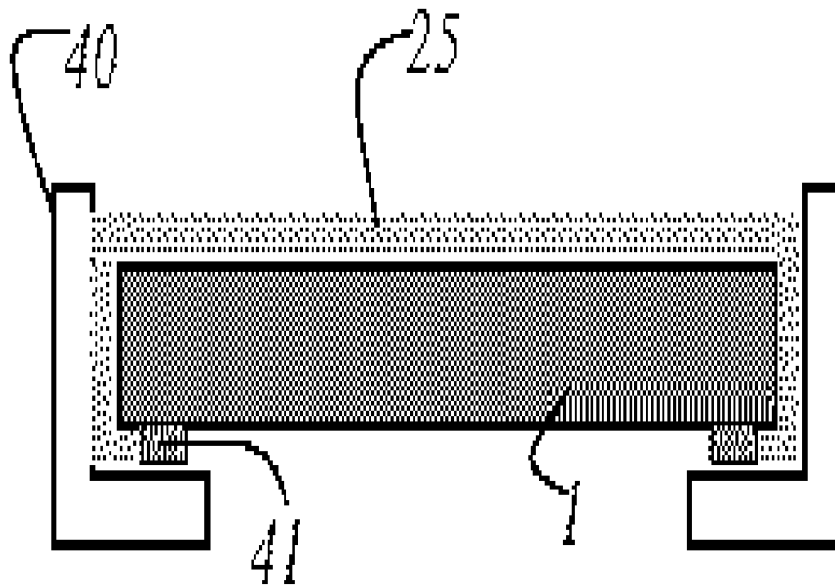

Fig. 6

1

APPARATUS FOR MEASURING FEATURE WIDTHS ON MASKS FOR THE SEMICONDUCTOR INDUSTRY

CROSS REFERENCE TO RELATED APPLICATIONS

This application claims priority of the German patent application 103 43 876.9, filed Sep. 23, 2003, which is incorporated by reference herein.

FIELD OF THE INVENTION

The invention concerns an apparatus for measuring feature widths on masks for the semiconductor industry.

BACKGROUND OF THE INVENTION

The established existing art for the optical measurement of feature widths on masks of the semiconductor industry is the use of microscopes in the visual (VIS), ultraviolet (UV), and deep ultraviolet (DUV) spectral regions using dry objectives. Dry objectives are characterized in that air is present between the specimen and the first optical surface of the microscope objective immediately adjacent to the specimen. As a consequence of this, the theoretical maximum possible numerical aperture NA is equal to 1; in practice, values of at most $NA \approx 0.95$ are attainable, and have in fact been achieved. The scope for higher apertures, i.e. higher resolution, has thus been exhausted.

SUMMARY OF THE INVENTION

It is the object of the invention to create an apparatus that extends the optical measurement of feature widths on masks to smaller feature widths than are possible with conventional optical feature width measurement.

The object is achieved by an apparatus for measuring feature widths on masks for the semiconductor industry, comprising a carrier plate that is retained in vibrationally decoupled fashion in a base frame; a scanning stage, arranged on the carrier plate, wherein the carrier plate carries the mask to be measured; an objective arranged opposite a surface of the mask; and a liquid is provided between the objective and the surface of the mask.

It is a further object of the invention to create an apparatus that extends the optical measurement of feature widths on semiconductor substrates to smaller feature widths than are possible with conventional optical feature width measurement.

The object is achieved by an apparatus for measuring feature widths on semiconductor substrates, comprising a carrier plate that is retained in vibrationally decoupled fashion in a base frame; a scanning stage, arranged on the carrier plate, wherein the carrier plate carries the semiconductor substrate to be measured; an objective arranged opposite a surface of the semiconductor substrate, wherein the wherein objective is configured for wavelengths of the illuminating light smaller than 300 nm; and a liquid is provided between the objective and the surface of the semiconductor substrate.

The apparatus for measuring feature widths on masks for the semiconductor industry encompasses a carrier plate that is retained in vibrationally decoupled fashion in a base frame.

The mask is arranged on a scanning stage arranged on the carrier plate. The mask has a surface opposite which an

2

objective is positioned. A liquid is provided between the objective and the surface of the mask.

Associated with the objective, in one embodiment, is a precision metering nozzle that applies the liquid exclusively onto at least one measurement point defined on the surface of the mask.

In a further advantageous embodiment of the invention, the objective possesses a device for applying the liquid exclusively onto at least one measurement point defined on the surface of the mask. The device can be embodied, in this context, as a cylinder that completely surrounds the objective, the cylinder being separated from the objective by a gap. In a further advantageous embodiment of the invention, the device is made up of at least one conduit that is arranged coaxially around the circumference of the objective.

A further possibility is that the liquid completely covers the surface of the mask. The mask is placed, in this context, in a special frame, and the mask rests on a special peripheral seal.

Further advantageous embodiments of the invention are evident from the dependent claims.

BRIEF DESCRIPTION OF THE DRAWINGS

The subject matter of the invention is depicted schematically in the drawings and will be described below with reference to the Figures, in which:

FIG. 1 schematically depicts a dry objective (according to the prior art) in relation to a surface having features to be measured;

FIG. 2 schematically depicts an embodiment of an apparatus for measuring feature widths;

FIG. 3 schematically depicts a first embodiment of an objective in spatial relation to the feature widths to be measured on the surface of a mask for semiconductor manufacture, a liquid being provided between the objective and the surface of the mask for semiconductor manufacture;

FIG. 4 schematically depicts a second embodiment of an objective having a device for applying a liquid onto the surface of a mask for semiconductor manufacture;

FIG. 5a shows a first embodiment of the device for applying the liquid;

FIG. 5b shows a second embodiment of the device for applying the liquid; and

FIG. 6 shows a further embodiment of a system for applying a liquid onto the surface of a mask for semiconductor manufacture.

DETAILED DESCRIPTION OF THE INVENTION

The specification below refers exclusively to masks. It has to be understood that the term mask is not limited to the masks exclusively. Mask may be understood as well as semiconductor substrates like a wafer.

FIG. 1 schematically depicts a dry objective 2 (according to the existing art) in relation to a surface 4 having features 4a to be measured. What is meant in this connection by "measurement of feature widths" is that the image of a feature 4a or line to be measured on a mask 1 for semiconductor production is imaged by means of a high-resolution optical system onto receiving surface 5a of a CCD camera 5. CCD camera 5 acquires the intensity profile of the linear image, and the line width of the acquired linear feature is determined therefrom using suitable image analysis software. It is thus possible to measure each line or feature 4a on mask 1 for semiconductor manufacture individually, and

3

to determine the line width. The resolution achievable with an optical system **2** is responsible for the smallest line width still measurable with the system. A characteristic magnitude of an imaging optical system, or objective **2**, that is critical in terms of resolution capability can be determined using the following equation:

$$P_{\lambda/2} > 0.25(\lambda/NA),$$

where $P_{\lambda/2}$ is the smallest line width that can still be resolved, λ the wavelength of the light used for illumination, and NA the numerical aperture of the imaging optical system or objective **2**. The numerical aperture is further defined as $NA = n \sin(\sigma)$, where n is the refractive index of medium **6** between objective **2** and surface **4** of mask **1**. Objective **2** is usually made up of several elements, so that n is the refractive index of medium **6** between the one front element **7** of objective **2** and mask **1**. σ is the semiaperture angle of the largest light cone angle **8** that can be transmitted (proceeding from a specimen point **9**) into image plane **10**, i.e. receiving surface **5a** of CCD camera **5**. It is evident from FIG. **1** that the aperture angle or semiaperture angle σ can be a maximum of 90 degrees, and $\sin(\sigma)$ can thus be a maximum of 1. As a result of manufacturing tolerances that must be observed, however, values of $\sin(\sigma)$ only ≤ 0.95 are attainable in practice for objectives for purely visual observation. Even more stringent manufacturing tolerances must be observed for objective **2** for the measurement of features **4a**, so that for this, values of $\sin(\sigma) \approx 0.90$ are almost impossible to exceed. This means that it is no longer possible to enhance resolution by increasing the aperture angle. Given a fixed predefined wave length λ , the only way to do so is to increase the refractive index n . This means that a medium **6** having a refractive index greater than that of air is used between surface **4a** of mask **4** and front element **7** of objective **2**.

FIG. **2** schematically depicts an embodiment of an apparatus **12** for measuring line widths of features **4a** on surface **4** of a mask **1**. Apparatus **12** comprises a base frame **14** in which a carrier plate **16** is retained in vibrationally decoupled fashion. Arranged on carrier plate **16** is a scanning stage **18** that carries mask **1** to be measured. In the embodiment depicted here, mask **1** is transilluminated by a transmitted illumination unit **20**. An imaging microscope unit **22** is arranged above mask **1**. Imaging microscope unit **22** is retained in a carrier unit **24** that itself is connected rigidly to carrier plate **16**. Objective **2** is arranged on imaging microscope unit **22** in such a way that it is located opposite mask **1**. The image of mask **1** acquired by objective **2** is imaged onto CCD camera **5**. Focusing can be performed either by way of a vertical displacement of scanning stage **18** or by way of a vertical displacement, integrated into microscope unit **22**, of objective **2**. In addition to transmitted illumination unit **20**, an incident illumination unit **26** can be provided as an internal or external component of microscope unit **22**. Apparatus **12** furthermore encompasses several electronics units **30**, for example a stage control system and CCD readout unit as well as a PC for evaluation and operation.

FIG. **3** schematically depicts a first embodiment of an objective **2** in spatial relation to the width of features **4a** to be measured on surface **4** of a mask **1** for semiconductor manufacture. The invention exploits the fact that the use of liquids **25** ("immersion media") between mask **1** and objective **2** allows the effective (numerical) aperture NA to be increased above the value of 1, and thus results in higher resolution. The numerical aperture NA is obtained by mul-

4

tiplying the refractive index n of the immersion medium by the sine of the aperture angle σ : $n \cdot \sin(\sigma)$. The relationship between NA and the smallest resolvable feature width Δ is $P_{\lambda/2} > 0.25 \cdot \lambda / NA$, where λ is the wavelength of the light. For air, $n=1$ (see FIG. **1**, existing art); when liquids **25** are used, refractive indices $n > 1.2$ are possible, so that a proportional increase in resolution is thereby achieved.

The use of liquids **25** in the measurement of masks was considered taboo in the existing art because of the risk of contaminating mask **1**. For that reason, this approach to higher resolution was not previously taken, or was generally ruled out as unacceptable in the search for new, higher-resolution solutions.

One possibility for liquid **25** as an immersion medium is water. Objective **2** is preferably configured for the deep ultraviolet (DUV) spectral region at a wavelength below 300 nm, e.g. 248 nm. Objective **2** can likewise be embodied for specific applications, but also for wavelengths greater than 300 nm. In addition to water as an ideal immersion medium, other liquids such as inert oils, for example Fomblin®, a perfluoropolyether oil, can also be used.

In the approach described here, a liquid **25** is provided between objective **2** and surface **4** of mask **1** for semiconductor manufacture. Liquid **25** wets both surface **4** of mask **1** and front element **7** of objective **2**. The liquid can be applied only in targeted and local fashion to measurement point **28** of mask **1** that is to be measured at that time; alternatively, however, wetting of the entire mask surface **4** is also conceivable. FIG. **3** depicts a first possibility for targeted application. For targeted application, a precision metering nozzle **27** is provided in the immediate vicinity of objective **2**. Measurement point **28** of mask **1** is always positioned in the immediate vicinity of an optical axis **31** defined by objective **2**, i.e. in the field of view of objective **2**. As a rule, the spacing between mask **1** and objective **2** is not large enough to allow liquid **25** to be applied with the nozzle in targeted fashion on measurement point **28**. In that case measurement point **28** is first positioned under tip **27a** of precision metering nozzle **27**. A droplet of liquid **25** is then applied onto measurement point **28**. Mask **1** is then displaced, using scanning stage **20**, in such a way that the liquid droplet and thus measurement point **28** are located beneath objective **2**. Objective **2** is lowered, or alternatively mask **1** is raised, so that front element **7** of the objective is also wetted by liquid **25**.

FIG. **4** schematically depicts a second embodiment of an objective **2** having a device **33** for applying liquid **25** onto surface **4** of mask **1** for semiconductor manufacture. Device **33** for applying liquid **25** is arranged symmetrically around optical axis **31** of objective **2**. As depicted in FIG. **5a**, device **33** is embodied as cylinder **35** that completely surrounds objective **2**. Cylinder **35** possesses a larger diameter than objective **2**, so that a gap **36** is created. Through gap **36**, liquid **25** is transported to measurement point **28**. In FIG. **5b**, device **33** for applying liquid **25** is embodied as at least one conduit **38**. One or more conduits **38** are arranged coaxially around the circumference of objective **2**. Through the one or more conduits **38**, liquid **25** is applied in suitable fashion onto surface **4** of mask **1**.

FIG. **6** shows a further embodiment of a system for applying a liquid **25** onto surface **4** of a mask **1** for semiconductor manufacture. In this embodiment, liquid **25** is distributed over the entire surface **4** of mask **1** for the measurement. Mask **1** is placed for that purpose in a special frame **40**. Mask **1** rests, in this context, on a special peripheral seal **41**, so that liquid **25** is distributed over the

5

entire surface 4 of mask 1 and is securely held in frame 40. Seal 41 is made, for example, of Teflon® material.

The invention has been described with regard to the preferred exemplary embodiments. It is self-evident to one skilled in the art that changes and modifications can be made without leaving the range of protection of the claims below.

What is claimed is:

1. An apparatus for measuring feature widths on masks for the semiconductor industry, comprising a carrier plate that is retained in vibrationally decoupled fashion in a base frame; a scanning stage, arranged on the carrier plate, wherein the carrier plate carries the mask to be measured; an objective arranged opposite a surface of the mask; a liquid is provided between the objective and the surface of the mask, and wherein a precision metering nozzle, which applies the liquid exclusively onto at least one measurement point located on the surface of the mask, is associated with the objective.

2. An apparatus for measuring feature widths on masks for the semiconductor industry, comprising:

a base frame;

a carrier plate retained in a vibrationally decoupled fashion in the base frame;

a mask comprising a surface;

an objective arranged opposite the surface of the mask; a scanning stage operatively arranged on the carrier plate to carry the mask;

a device associated with the objective, operatively arranged to apply a liquid between the objective and the surface of the mask.

3. The apparatus as recited in claim 2 wherein the mask further comprises at least one measurement point on the surface, and the device is operatively arranged to apply the liquid exclusively onto the at least one measurement point.

4. The apparatus as recited in claim 2 wherein the device comprises a precision metering nozzle.

5. The apparatus as recited in claim 2 wherein the device is integral to the objective.

6. The apparatus as recited in claim 5 wherein the device comprises a cylinder completely surrounding the objective and separated from the objective by a gap.

7. The apparatus as recited in claim 6 wherein the liquid is transportable through the gap.

8. The apparatus as recited in claim 5 wherein the objective comprises a circumference and the device comprises at least one conduit arranged coaxially with the circumference of the objective.

9. The apparatus as recited in claim 8 wherein the liquid is transportable through the at least one conduit.

6

10. The apparatus as recited in claim 9 wherein the device comprises three conduits.

11. The apparatus as recited in claim 2 further comprising a special frame and a special peripheral seal, wherein the mask is arranged in the special frame and on the special peripheral seal, and wherein the liquid applied to the surface is securely contained within the special frame.

12. The apparatus as recited in claim 11 wherein the special seal comprises polytetrafluoroethylene.

13. The apparatus as recited in claim 2 wherein the liquid comprises water.

14. The apparatus as recited in claim 2 wherein the liquid comprises oil.

15. The apparatus as recited in claim 2 wherein the objective is configured for wavelengths of the illuminating light smaller than 300 nm.

16. The apparatus as recited in claim 2 wherein the objective is configured for wavelengths of the illuminating light smaller than 248 nm.

17. The apparatus as recited in claim 2 wherein the objective is wetted with the liquid.

18. An apparatus for measuring feature widths on semiconductor substrates, comprising:

a base frame;

a carrier plate retained in a vibrationally decoupled fashion in the base frame;

a semiconductor substrate comprising a surface;

an objective arranged opposite the surface of the semiconductor substrate;

a scanning stage operatively arranged on the carrier plate to carry the semiconductor substrate;

a device associated with the objective, operatively arranged to apply a liquid between the objective and the surface of the semiconductor substrate.

19. The apparatus as recited in claim 18 wherein the semiconductor substrate further comprises at least one measurement point on the surface, and the device is operatively arranged to apply the liquid exclusively onto the at least one measurement point.

20. The apparatus as recited in claim 18 wherein the objective is configured for wavelengths of the illuminating light smaller than 300 nm.

21. The apparatus as recited in claim 18 wherein the objective is configured for wavelengths of the illuminating light smaller than 248 nm.

22. The apparatus as recited in claim 18 wherein the objective is wetted with the liquid.

* * * * *