



US008523443B2

(12) **United States Patent**
Traiser

(10) **Patent No.:** **US 8,523,443 B2**

(45) **Date of Patent:** ***Sep. 3, 2013**

(54) **LINEAR GUIDANCE SYSTEM COMPRISING
A HOLLOW-PROFILE RAIL**

(75) Inventor: **Reinhold Traiser**, Bad Camberg (DE)

(73) Assignee: **Accuride International GmbH**, Diez (DE)

(*) Notice: Subject to any disclaimer, the term of this patent is extended or adjusted under 35 U.S.C. 154(b) by 625 days.

This patent is subject to a terminal disclaimer.

(21) Appl. No.: **12/733,342**

(22) PCT Filed: **Aug. 22, 2008**

(86) PCT No.: **PCT/EP2008/061029**

§ 371 (c)(1),
(2), (4) Date: **May 28, 2010**

(87) PCT Pub. No.: **WO2009/027344**

PCT Pub. Date: **Mar. 5, 2009**

(65) **Prior Publication Data**

US 2010/0254638 A1 Oct. 7, 2010

(30) **Foreign Application Priority Data**

Aug. 25, 2007 (DE) 10 2007 040 230

(51) **Int. Cl.**
F16C 29/04 (2006.01)

(52) **U.S. Cl.**
USPC **384/49**; 384/51; 384/54

(58) **Field of Classification Search**
USPC 384/18, 19, 23, 43, 45, 51, 523, 526-528,
384/54

See application file for complete search history.

(56) **References Cited**

U.S. PATENT DOCUMENTS

2,566,421 A *	9/1951	Lapointe	384/526
2,812,222 A	11/1957	Gussack	
3,113,807 A *	12/1963	Polidor	384/49
3,145,065 A	8/1964	Cator	
3,650,578 A *	3/1972	Del Vecchio et al.	384/18
3,801,166 A *	4/1974	York	384/18
4,291,929 A *	9/1981	Faust	384/18
4,629,260 A	12/1986	Kasai	
4,655,613 A	4/1987	Yokota	

(Continued)

FOREIGN PATENT DOCUMENTS

DE	4314115 A1	11/1994
DE	29604922 U1	5/1996

(Continued)

Primary Examiner — Marcus Charles

(74) *Attorney, Agent, or Firm* — Michael L. Dunn

(57) **ABSTRACT**

A linear guidance system including a guide rail (1) and a carriage (2) guided displaceably on the guide rail by at least two ball bearings (3, 3'), wherein the ball bearings comprise a plurality of balls (4) and a ball cage (5) and the guide rail (1) has running surfaces (9, 9') and the carriage (2) has running surfaces (10, 10') for the rolling movement of the balls (4) of the ball bearings (3, 3'), wherein the carriage (2) includes a profile member (11) which is substantially C-shaped in cross-section, wherein the running surfaces (10, 10') are provided at end portions (11', 11'') of the C-shaped profile member (11) and the carriage (2) further includes a plate (12) which extends between end portions (11', 11'') of the C-shaped profile member (11) of the carriage (2) and is connected to the end portions (11', 11''), forming a closed hollow profile.

17 Claims, 5 Drawing Sheets

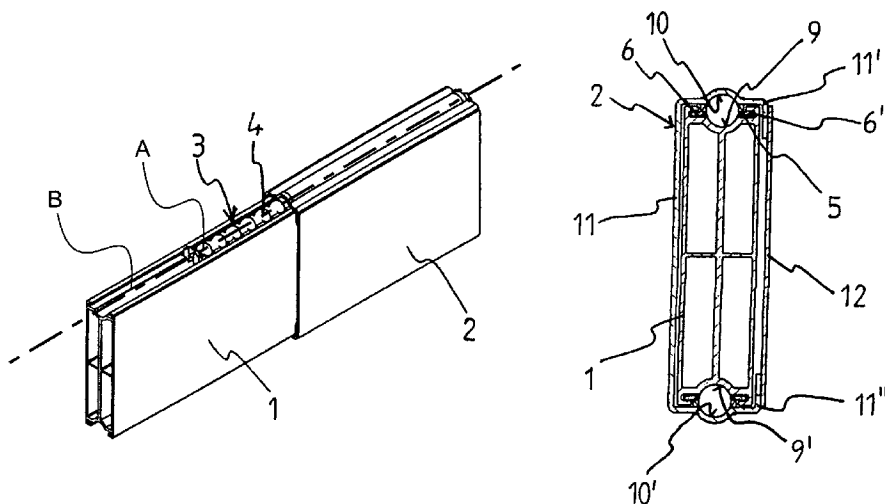

(56)

References Cited

U.S. PATENT DOCUMENTS

4,921,359	A *	5/1990	Sakamoto	384/18
4,991,981	A *	2/1991	Baxter	384/18
5,022,768	A *	6/1991	Baxter	384/19
5,106,207	A *	4/1992	Fry	384/49
5,156,462	A *	10/1992	Jacob et al.	384/49
5,201,584	A *	4/1993	Simons	384/49
5,301,914	A *	4/1994	Yoshida et al.	248/430
5,553,946	A	9/1996	Agari	
5,993,064	A *	11/1999	Teramachi et al.	384/51
6,105,920	A	8/2000	Gauger	
6,142,671	A *	11/2000	Ise	384/45

6,347,849	B1 *	2/2002	Muterthies et al.	384/19
6,378,968	B1 *	4/2002	Weng	312/334.11
6,736,730	B2 *	5/2004	Sugiyama et al.	464/111
7,178,888	B2 *	2/2007	Judge et al.	312/334.46
7,213,896	B2 *	5/2007	Chi	384/18
8,201,901	B2 *	6/2012	Craddock	312/334.11

FOREIGN PATENT DOCUMENTS

EP	0470477	A1	2/1992
EP	0533399	A1	3/1993
GB	738486		10/1955
GB	2213211	A	3/1989
JP	08326745	A *	12/1996

* cited by examiner

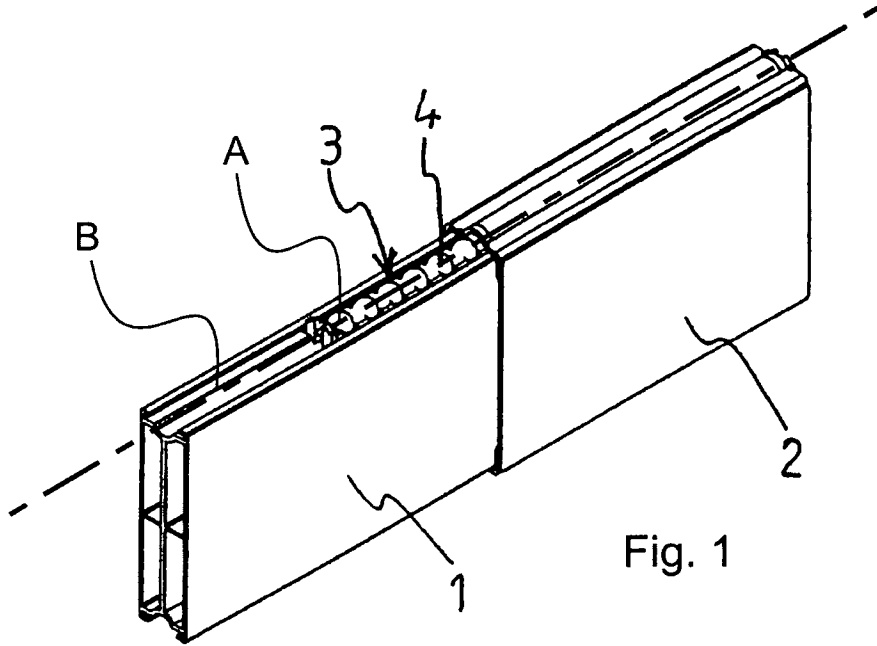

Fig. 1

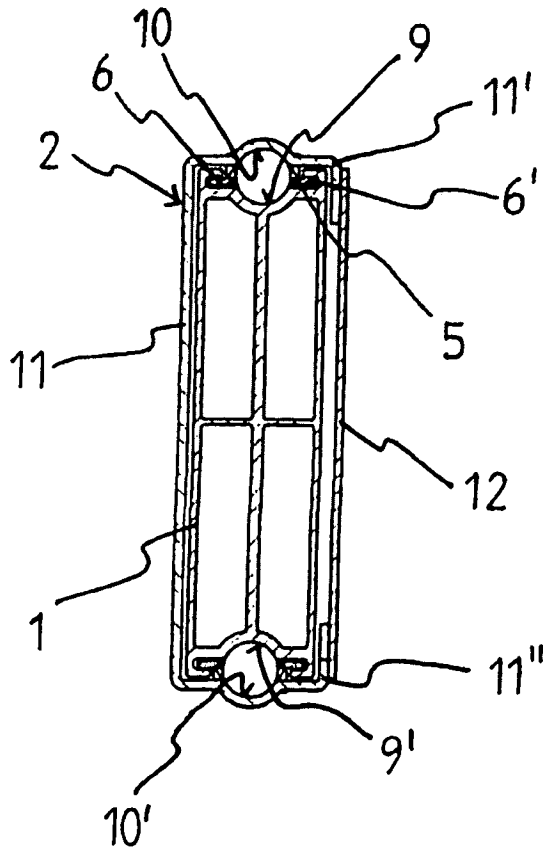

Fig. 2

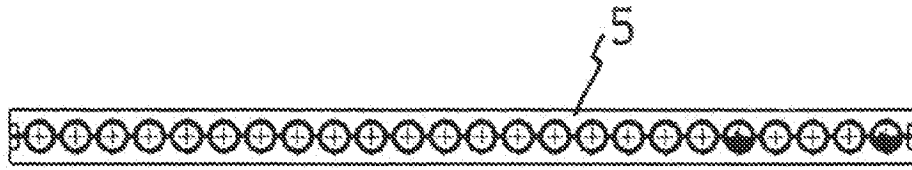

Fig. 3a

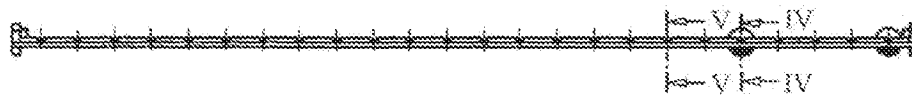

Fig. 3b

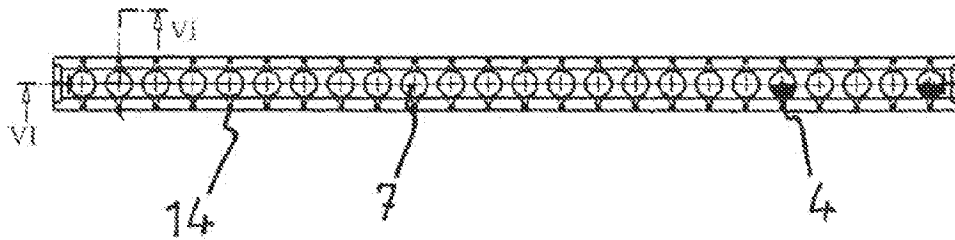

Fig. 3c

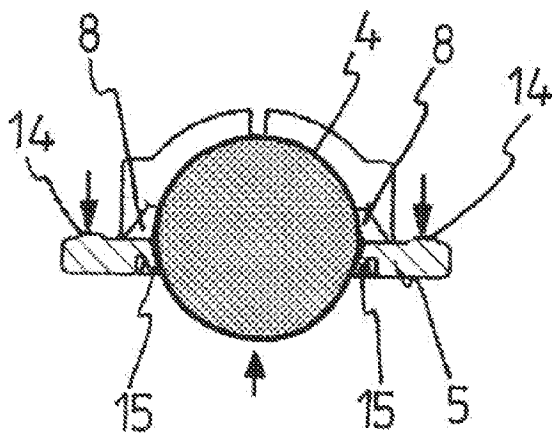

Fig. 4

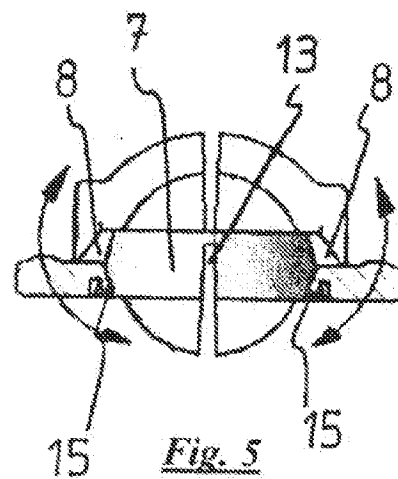

Fig. 5

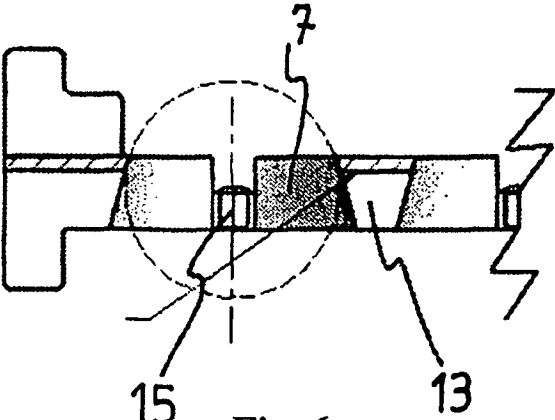

Fig. 6

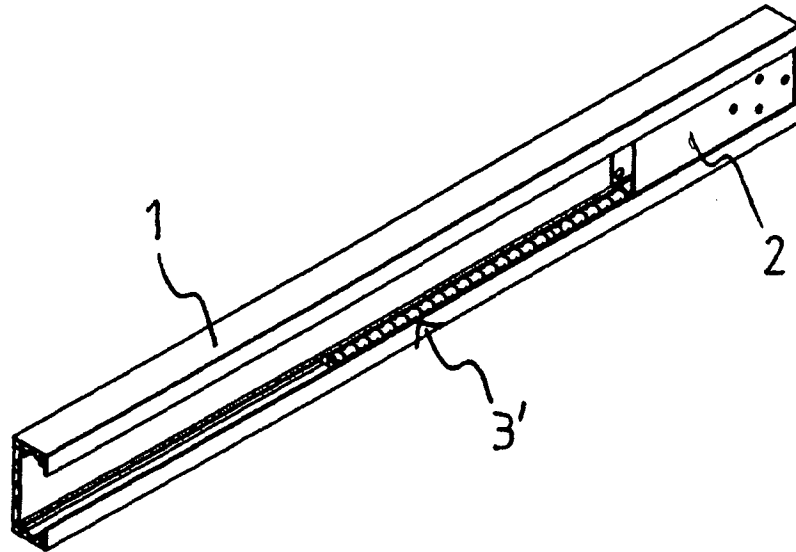

Fig. 7

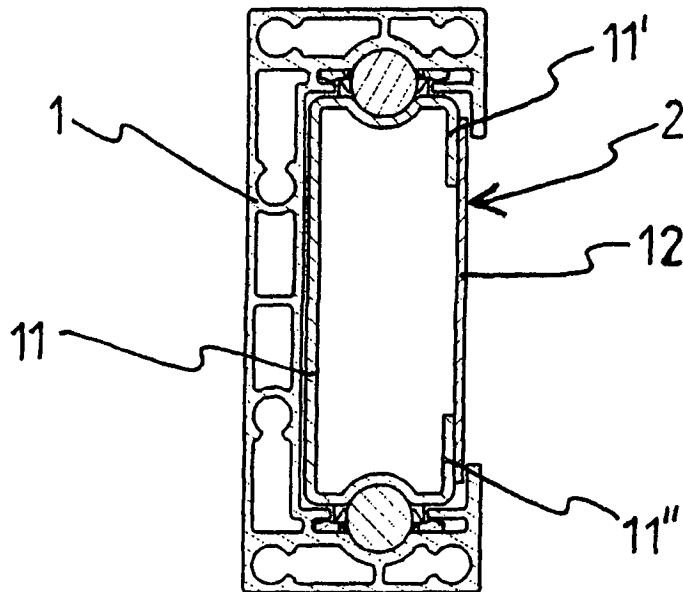

Fig. 8

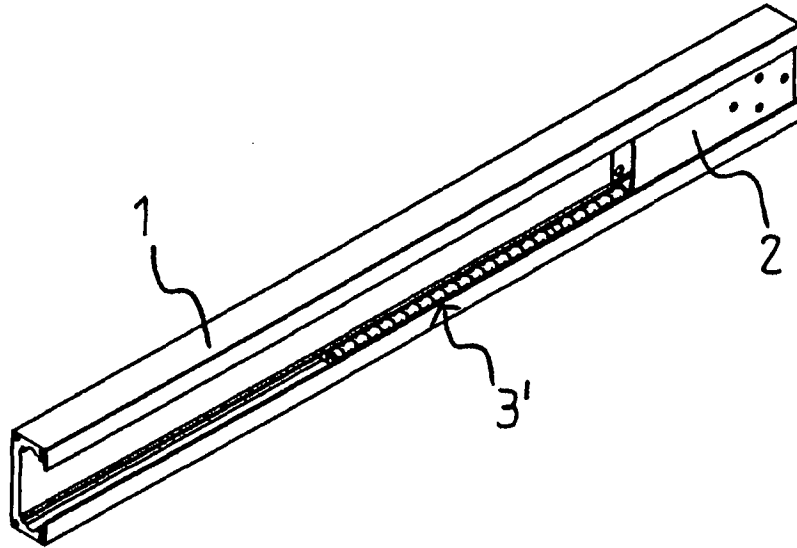

Fig. 9

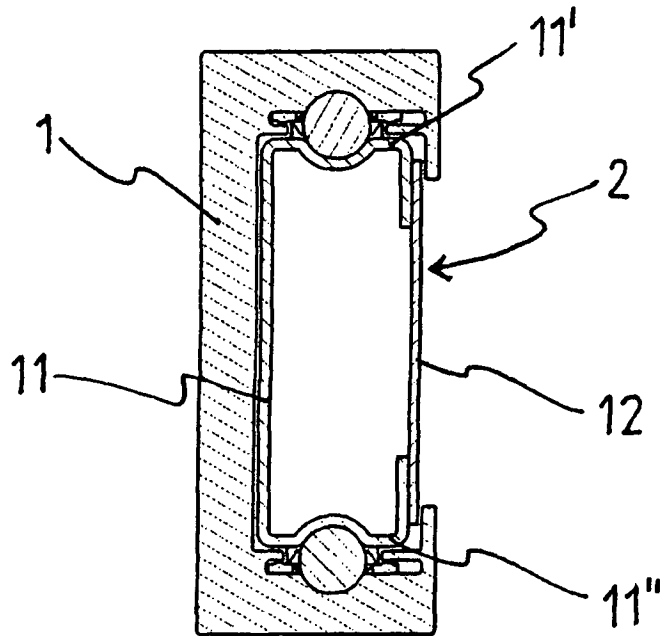

Fig. 10

1

LINEAR GUIDANCE SYSTEM COMPRISING A HOLLOW-PROFILE RAIL

CROSS REFERENCE TO RELATED APPLICATIONS

This claims priority from German Patent Application DE 102007040230.0 filed Aug. 25, 2007 and is a 371 (national stage) application of PCT Application PCT/EP2008/061029 filed Aug. 22, 2008

BACKGROUND OF THE INVENTION

The invention concerns a linear guidance system comprising a guide rail and a carriage which is guided displaceably on the guide rail by way of at least two ball bearings, wherein the ball bearings respectively comprise a plurality of balls and a ball cage and the guide rail has running surfaces and the carriage has running surfaces for the rolling movement of the balls of the ball bearings.

Linear guidance systems can be used in the most widely varying areas. Automobile engineering involves the use of linear guidance systems with a high load-bearing capacity inter alia for vehicle sliding doors, load floor pans, variable-length consoles in the vehicle interior and other devices.

In the area of vehicle sliding doors, for reasons of stability guide rails on which the sliding doors are guided are frequently mounted at the outside of the bodywork. Such mounting at the outside of the bodywork admittedly ensures a high stability for the guidance system under the loading of the weight of the sliding door, but the guide rails mounted on the outside of the bodywork are visible when the sliding door is closed and considerably spoil visual appearance. In addition, by virtue of being fitted on the outside of the vehicle, those guide rails are constantly exposed to external weather conditions and therefore corrode more rapidly than internally mounted guidance systems or require a considerably higher level of corrosion protection. In addition such guide rails are profiled so that dirt out of the environment rapidly accumulates at and in the rails and that very rapidly causes a deterioration in the running properties of the guidance system.

A sliding door for motor vehicles having a guide rail mounted on the inside of the door, in which some of the aforementioned disadvantages of guide rails mounted on the outside of the bodywork are overcome is disclosed in DE 43 14 115 A1. The described guidance system for a motor vehicle sliding door however does not have particularly good running properties and thus does not have a good feel and is comparatively noisy.

The object of the present invention was that of providing a linear guidance system which can carry high loads, which involves the production of a low level of noise, which is of a compact structure, which permits long displacement travel movements and which is comparatively inexpensive to produce. A further object of the invention was that of providing a linear guidance system for vehicle sliding doors, load floor pans, variable-length consoles in the vehicle interior etc, having the aforementioned properties.

BRIEF DESCRIPTION OF THE SEVERAL VIEWS OF THE DRAWINGS

FIG. 1 shows a perspective view inclinedly from above of a linear guidance system according to the invention in which the carriage embraces the guide rail,

2

FIG. 2 shows a view in cross-section in relation to its longitudinal extent of the linear guidance system according to the invention of FIG. 1,

FIG. 3a shows a bottom view of a strip-shaped ball cage of the linear guidance system according to the invention,

FIG. 3b shows a side view of a strip-shaped ball cage of the linear guidance system according to the invention,

FIG. 3c shows a top view of a strip-shaped ball cage of the linear guidance system according to the invention,

FIG. 4 shows a cross-section through the strip-shaped ball cage of FIG. 3 along section line C-C,

FIG. 5 shows a cross-section through the strip-shaped ball cage of FIG. 3 along section line D-D,

FIG. 6 shows a cross-section through the strip-shaped ball cage of FIG. 3 along section line F-F,

FIG. 7 shows a perspective view inclinedly from above of a further embodiment of a linear guidance system according to the invention, in which the guide rail embraces the carriage,

FIG. 8 shows a view in cross-section in relation to its longitudinal extent of the linear guidance system according to the invention of FIG. 7,

FIG. 9 shows a perspective view inclinedly from above of a further embodiment of a linear guidance system according to the invention, in which the guide rail embraces the carriage, and

FIG. 10 shows a view in cross-section in relation to its longitudinal extent of the linear guidance system according to the invention of FIG. 9.

BRIEF SUMMARY OF THE INVENTION

According to the invention that object is attained by a linear guidance system of the kind set forth in the opening part of this specification, which is characterised in that the carriage includes a profile member which is substantially C-shaped in cross-section, wherein the running surfaces are provided at the respective end portions of the C-shaped profile member and the carriage further includes a plate which extends between the end portions of the C-shaped profile member of the carriage and is connected to said end portions, forming a closed hollow profile member.

More specifically the invention is a linear guidance system including a guide rail (1) and a carriage (2) which is guided displaceably on the guide rail by way of at least two ball bearings (3, 3'). The ball bearings respectively include a plurality of balls (4) and a ball cage (5). The guide rail (1) has running surfaces (9, 9') and the carriage (2) has running surfaces (10, 10') for the rolling movement of the balls (4) of the ball bearings (3, 3'). The carriage (2) includes a profile member (11) which is substantially C-shaped in cross-section. The running surfaces (10, 10') are provided at the respective end portions (11', 11'') of the C-shaped profile member (11). The carriage (2) further includes a plate (12) which extends between the end portions (11', 11'') of the C-shaped profile member (11) of the carriage (2) and is connected to the end portions (11', 11''), forming a closed hollow profile.

DETAILED DESCRIPTION OF THE INVENTION

The term ball cage in accordance with the present invention includes all kinds of known ball cages, in particular strip-shaped ball cages, which hold the balls of a single ball raceway or rolling surface, and bridge ball cages in which the ball cages for a plurality of ball raceways or rolling surfaces are

3

connected together by way of a connecting element referred to as a bridge. The strip ball cage is preferred in accordance with the invention.

In general and in accordance with the invention preferably the C-shaped profile member of the carriage is in one piece. The invention however also includes those variants in which the C-shaped profile member is composed of a plurality of individual elements. That can be for example two mutually opposite U-shaped profile members which include running surfaces for the rolling movement of the balls and which form the end portions of the C-shaped profile member, and a plate-shaped member which extends between the two U-shaped profile members and connects together them and substantially like the plate according to the invention which would then be arranged on the opposite side of the plate-shaped member.

The overall length of the linear guidance system is substantially predetermined by the length of the guide rail. The carriage guided displaceably on the guide rail is considerably shorter than the guide rail. The maximum displacement travel is determined by the overall length of the guide rail and the ratio of the length of the carriage to the length of the guide rail. With a given length for the guide rail the maximum possible displacement travel for an object secured to the carriage is correspondingly longer, the shorter the carriage is. The selection of the length of the carriage guided displaceably on the guide rail is determined however not only in accordance with the desired displacement travel but also in accordance with the required load-bearing capacity and stability of the linear guidance system. The longer the carriage is, the correspondingly higher are the load-bearing capacity, running stability and quietness and smoothness of operation, as, with a ball bearing of the same configuration, a longer carriage is rolled at the same time on more balls than a shorter carriage.

With the linear guidance system according to the invention the carriage has a plate which extends between the end portions of the substantially C-shaped profile member of the carriage and is connected to the end portions non-releasably or releasably, preferably non-releasably. In a preferred embodiment the plate is connected to the end portions of the C-shaped profile member by means of a welded connection. The C-shaped profile member and the plate secured between the end portions thereof form in cross-section a closed hollow profile like a profile member closed in a tubular configuration.

In a variant of the linear guidance system according to the invention the carriage formed as a hollow profile member from the C-shaped profile member and the plate embraces the guide rail. This variant is shown for example in accompanying FIGS. 1 and 2.

In an alternative variant of the linear guidance system according to the invention the guide rail has a profile member which is substantially C-shaped in cross-section and at the respective end portions of which the running surfaces are provided and which embraces the carriage formed as a hollow profile from the C-shaped profile member and the plate. This variant is shown for example in accompanying FIGS. 7, 8, 9 and 10.

Closure of the C-shaped profile member of the carriage to constitute a hollow profile or tubular profile by means of the plate connected to the end portions of the C-shaped profile member achieves a very high loading value and extremely good torsional stability and good overload safety for the linear guidance system.

The use of a plate for connecting the respective end portions of the C-shaped profile member of the carriage has the further advantage that tolerances of the individual parts, which occur in production of the linear guidance system, can

4

be compensated when connecting the plate to the end portions of the C-shaped profile member. When the plate is connected to the end portions of the C-shaped profile member, the C-shaped profile member can be compressed to a greater or lesser degree to compensate for tolerances and remains in that position after the plate is connected to the end portions. It is possible in that way to compensate not only for tolerances in manufacture of the C-shaped profile member of the carriage but also tolerances in manufacture of the guide rail.

In a preferred embodiment of the linear guidance system according to the invention the plate for connecting the respective end portions of the C-shaped profile member of the carriage is an apertured plate with through openings for mounting securing means. Such an apertured plate is lower in weight than a continuous plate and affords many different securing and mounting options.

In a further embodiment of the linear guidance system according to the invention the ball cage has a plurality of substantially circular through openings which are arranged in succession in a row and into which the balls are inserted, wherein the inside diameter of the through openings tapers conically in the direction from a running surface of the guide rail to the associated running surface of the carriage to an inside diameter or is constricted by limiting means to an inside diameter which is smaller than the diameter of the balls so that the balls are secured in the through openings to prevent them from falling out of the through openings in the direction of the running surface of the carriage.

With this embodiment of the strip-shaped ball cage of the linear guidance system according to the invention the balls are fitted in the through openings and are prevented from falling out upwardly, that is to say in the direction from a running surface of the guide rail towards the associated running surface of the carriage, insofar as either the inside diameter of the through openings is tapered conically to an inside diameter which is smaller than the diameter of the balls, or the inside diameter of the through openings is constricted by limiting means to an inside diameter which is smaller than the diameter of the balls.

In a further embodiment of the linear guidance system according to the invention the ball cage is elastically deformable and is secured to the guide rail.

In a further embodiment of the linear guidance system according to the invention the balls are held with a prestressing against the running surfaces of the guide rail by the ball cage. That ensures that the balls always bear against the running surfaces of the guide rail, thereby avoiding chattering and rattling and troublesome noise generation on the part of the ball bearing, for example when vibration occurs, and more specifically even with balls which are precisely not under a loading between the running rail and the carriage. To ensure the prestressing effect the ball cage is elastically deformable or flexible.

In a further embodiment provided at the through openings of the ball cage are elastically deformable holding means which are of such a configuration that they secure the balls to prevent them from falling out of the through openings in the direction of the running surface, arranged under the ball cage, of the guide rail, when the balls do not bear against the running surface. As the balls are held with a prestressing against the running surfaces of the guide rail by the ball cage and the upper holding means, that securing effect comes into operation only when the balls do not bear against the running surface, for example upon assembly and storage of the ball cage.

Preferably the elastically deformable holding means, in the direction of the running surface arranged under the ball cage,

5

are in the form of legs which are prestressed elastically towards the center of the through openings. As those holding means are only required when the balls do not bear against the running surface it is sufficient if there are provided one or two such legs at each through opening to secure the ball in the through opening to prevent it from falling out. It will be appreciated that it is also possible to provide a plurality of such legs. Upon assembly of the ball cage, namely when inserting the balls into the through openings in the ball cage, the balls are inserted into the ball cage from below, in which case the holding means or legs are temporarily urged apart so that a ball can be inserted.

The strip-shaped ball cage is simple and inexpensive to produce and fit to the guide rail and affords good running properties for the linear guidance system. The length of the ball cage and the number of balls and through openings arranged therein substantially depends on the overall length of the guidance system and the displacement travel movement, but also on the required load-bearing capacity of the linear guidance system, the desired feel and smoothness and quietness of running operation.

In a preferred embodiment of the linear guidance system according to the invention the side edges in the longitudinal extent of the strip-shaped ball cage engage into two grooves disposed in mutually opposite relationship in the longitudinal extent of the guide rail for securing the ball cage to the guide rail. For that purpose, besides the running surfaces of the guide rail, there are provided two grooves which face towards each other with their openings. The side edges of the strip-shaped ball cage are introduced into those grooves. In that case the arrangement of the grooves is so selected that the ball cage is slightly bent upon fixing transversely with respect to its longitudinal axis and by virtue of its flexibility or elasticity always urges the balls with a prestressing against the running surface of the guide rail. Desirably therefore the strip-shaped ball cage is made from a flexible elastic material, preferably plastic material. It can however also be made from metal, for example steel or high-quality steel.

In a quite particularly preferred embodiment of the linear guidance system according to the invention the guide rail on two mutually opposite sides has respectively one running surface and one ball bearing. Alternatively however it is also possible to provide on the guide rail more than two running surfaces and two ball bearings, for example two running surfaces and two ball bearings on each side of the guide rail. For most applications however it is sufficient if there is respectively precisely one running surface and one ball bearing provided on each of the oppositely disposed sides of the guide rail.

In a further preferred embodiment of the linear guidance system according to the invention the strip-shaped ball cage in its longitudinal extent at least portion-wise and preferably over its entire length has at least one torsion groove (groove-shaped opening). Preferably the at least one torsion groove is arranged on the side of the ball cage, that is towards the running surfaces of the guide rail. That at least one torsion groove influences or alters the elastic flexibility of the strip-shaped ball cage transversely to its longitudinal axis. The prestressing force of the balls against the running surfaces of the guide rail can be varied or adjusted, by the width and depth of the at least one torsion groove. A further advantage of the at least one torsion groove is that it can serve as a storage chamber for a lubricant which is usually employed in relation to ball bearings.

In a further preferred embodiment of the linear guidance system according to the invention the strip-shaped ball cage, on the side remote from the running surfaces of the guide rail,

6

has a plurality of knob-shaped raised portions arranged in succession in a row and in the proximity of the side edges in the longitudinal extent of the ball cage. Those knob-shaped raised portions have a number of advantages. The rolling movement of the balls on the running surface of the guide rail upon displacement of the carriage provides that the entire ball cage is also entrained or displaced in the longitudinal direction of the guide rail. The knob-shaped raised portions in the proximity of the side edges of the strip-shaped ball cage reduce the contact area of the regions of the side edges within the grooves provided on the guide rail for holding the ball cage, and thus the frictional resistance. In addition the knob-shaped raised portions provide for good distribution of lubricant which is desirably provided in the grooves on the guide rail for easier displacement of the ball cage.

In a further preferred embodiment the strip-shaped ball cage, at its two end portions, has end abutments which are of such a configuration that the carriage cannot be displaced beyond an end of the ball cage but encounters the end abutment upon reaching an end of the ball cage. When that occurs and if the end of the guide rail has not yet been reached in the displacement of the carriage the carriage pulls or entrains the ball cage to the end of the displacement travel. The end abutments at the respective ends of the ball cage ensure that the carriage always remains with its full length over the ball cage and is not displaced therebeyond. That improves stability, running properties and load-bearing capacity of the guidance system according to the invention.

Further advantages, features and configurations of the linear guidance system according to the invention will be apparent from the description hereinafter of a preferred embodiment and the accompanying Figures.

In the various Figures parts which involve mutually corresponding functions are denoted by the same references, even if they can differ from each other in their specific configuration.

FIG. 1 shows a perspective view inclinedly from above of a particularly preferred embodiment of the linear guidance system according to the invention comprising a guide rail 1, a carriage 2 and two ball bearings 3 and 3'. As shown in FIG. 2 the guide rail 1 in this embodiment which is particularly preferred according to the invention is produced in the form of a profile member produced by extrusion, preferably comprising aluminum. The guide rail 1 is of a substantially box-shaped profile having cavities and stabilisation struts in its interior. Running surfaces 9 and 9' are arranged on two opposite sides of the guide rail. The profile member extends further laterally of the running surfaces forming mutually facing grooves 6 and 6', into which the side edges of the ball cage 5 engage. The ball cage 5 is equipped with balls 4 which are secured upwardly against falling out by the inside diameter of the through openings tapering conically. The ball cage 5 holds the balls 4 with a prestressing against the running surfaces 9 and 9' of the guide rail 1.

It can further be clearly seen from FIG. 2 that the carriage 2 comprises a substantially C-shaped profile member 11 with running surfaces 10 and 10' and a plate 12 connected to the end portions 11' and 11'' of the C-shaped profile member 11. The C-shaped profile member 11 and the plate 12 connected thereto form a closed hollow profile. The plate 12 is welded to the end portions 11' and 11'' of the C-shaped profile member 11.

The plate 12 in FIG. 1 can be an apertured plate (not shown). The apertured plate 12 can be used for securing an object to be displaced, when the guide rail is mounted stationarily. Alternatively the carriage 2 can be secured by way of the apertured plate stationarily and the guide rail 1 can be

7

secured to an object to be displaced such as for example a vehicle sliding door. The guide rail is usually secured by way of connecting portions fixed to the respective ends of the guide rail (not shown).

FIGS. 3a, 3b and 3c show the strip-shaped ball cage 5 which is suitable according to the invention, with in this view only two balls 4 arranged in the through openings 7. It will be appreciated that, in a completely assembled linear guidance system, a ball 4 is provided in each or at least most of the through openings 7.

FIG. 4 shows a cross-sectional view on an enlarged scale of the ball cage 5 of FIG. 3 along the section line IV-IV. The conical tapering of the inside diameter of the through opening 7 and the holding means 15 in the form of elastic legs can be clearly seen herein. The conically tapered wall surface 8 of the through opening bears against the ball above the central plane of the ball and the holding means 15 bear against the ball beneath the central plane thereof and thus prevent the ball from falling out of the through opening 7. The ball cage is desirably strip shaped and side edges (5', 5''), are provided in a longitudinal extent (A) of the strip-shaped ball cage (5) that can engage into two grooves (6, 6') disposed in mutually opposite relationship in a longitudinal extent (B) of the guide rail (1) for securing the ball cage (5) to the guide rail.

It can also be clearly seen from FIG. 4 that knob-shaped raised portions 14 are arranged on the ball cage 5 in the proximity of the side edges. The lower view in FIG. 3 shows that the knob-shaped raised portions 14 are arranged in succession in a row and at uniform spacings on the top side of the ball cage 5. The knob-shaped raised portions 14 reduce the contact area of the ball cage in the grooves 6 and 6' on the guide rail 1 and thus reduce the frictional resistance.

FIG. 5 shows a cross-section through the ball cage 5 in FIG. 3 along the section line V-V. FIG. 5 shows essentially the same sectional view as FIG. 4 but without a ball fitted into the sectioned through opening 7.

As shown in FIG. 5 the ball cage 5, on the underside, has a torsion groove 13 (groove-shaped opening) which extends substantially over the entire length of the ball cage and which influences the flexibility and elasticity of the ball cage transversely with respect to its longitudinal extent. Thus the prestressing (prestressing force) of the balls against the running surfaces 9 and 9' of the guide rail 1 can be varied or adjusted by the selection of the width and depth of the torsion groove 13. In the present description reference is made to a torsion groove although that extends through the through openings of the ball cage and no longer actually represents a groove in the through openings. It would equally be possible also to refer to many individual (small) torsion grooves which extend in the longitudinal direction of the ball cage in the regions between adjacent through openings.

FIG. 6 shows a section through the strip-shaped ball cage of FIG. 3 along the section line VI-VI. It is also possible to clearly see in FIGS. 3 through 6 the end abutments which project upwardly beyond the end portions of the strip-shaped ball cage and which are of such a configuration that the carriage cannot be displaced beyond an end of the ball cage.

FIGS. 7 through 10 show alternative embodiments of linear guidance systems according to the invention, in which the guide rail 1 embraces the carriage 2 in the form of a closed hollow profile member. In this case also the carriage 2 comprises a substantially C-shaped profile member 11, the end portions of which are connected together by way of a plate 12 extending between the end portions 11', 11''. The guide rail 1 is substantially C-shaped and embraces the carriage 2 in the form of a closed hollow profile member so that the carriage 2 is guided in the interior of the guide rail 1. In the embodiment

8

of FIGS. 7 and 8 the guide rail 1 is in the form of a profile member produced by extrusion, with inner cavities and stabilisation struts, whereas the guide rail 1 in FIGS. 9 and 10 is in the form of solid material. It will be seen from FIGS. 7 and 9 that the plate 12 has mounting bores for securing to a body or an object intended for displacement.

REFERENCES

- 10 A longitudinal extent of the ball cage
- B longitudinal extent (B) of the guide rail
- 1 guide rail
- 2 carriage
- 3, 3' ball bearing
- 4 balls
- 5 ball cage
- 5', 5'' ball cage side edges
- 6, 6' grooves
- 7 through openings
- 8 tapered walls of the through openings
- 9, 9' running surfaces of the guide rail 1
- 10, 10' running surfaces of the C-shaped profile member 11
- 11 C-shaped profile member
- 11', 11'' end portions of the C-shaped profile member 11
- 12 plate
- 13 torsion groove
- 14 knob-shaped raised portions
- 15 holding means

What is claimed is:

1. A linear guidance system comprising a guide rail (1) and a carriage (2) which is guided displaceably on the guide rail by way of at least two ball bearings (3, 3'), wherein the ball bearings respectively comprise a plurality of balls (4) and a ball cage (5) and the guide rail (1) has running surfaces (9, 9') and the carriage (2) has running surfaces (10, 10') for the rolling movement of the balls (4) of the ball bearings (3, 3'), wherein the carriage (2) includes a profile member (11) which is substantially C-shaped in cross-section, wherein the running surfaces (10, 10') are provided at the respective end portions (11', 11'') of the C-shaped profile member (11) and the carriage (2) further includes a plate (12) which extends between the end portions (11', 11'') of the C-shaped profile member (11) of the carriage (2) and is connected to said end portions (11', 11''), forming a closed hollow profile.

2. A linear guidance system as set forth in claim 1 wherein the plate (12) is connected to the end portions (11', 11'') of the substantially C-shaped profile member (11) of the carriage (2).

3. The linear guidance system of claim 2 wherein the plate (12) is non-releasably connected to the end portions (11', 11'').

4. The linear guidance system of claim 2 wherein the plate (12) is welded to the end portions (11', 11'').

5. A linear guidance system as set forth in claim 2 wherein the carriage (2), closed in cross-section, embraces the guide rail (1).

6. A linear guidance system as set forth in claim 1 wherein the carriage (2), closed in cross-section, embraces the guide rail (1).

7. A linear guidance system as set forth in claim 1 wherein the guide rail (1) has a profile member which is substantially C-shaped in cross-section which embraces carriage (2) and has the running surfaces (9, 9') at ends of the profile member.

8. A linear guidance system as set forth in claim 1 wherein the plate (12) is an apertured plate with through openings for mounting securing means.

9

9. A linear guidance system as set forth in claim 1 wherein the ball cage (5) has a plurality of substantially circular through openings (7) which are arranged in succession in a row and into which the balls (4) are inserted, wherein the inside diameter of the through openings tapers conically in the direction from a running surface (9, 9') of the guide rail to the associated running surface (10, 10') of the carriage (2) to an inside diameter or is constricted by limiting means to an inside diameter which is smaller than the diameter of the balls so that the balls are secured in the through openings (7) to prevent them from falling out of the through openings (7) in the direction of the running surface (10, 10') of the carriage.

10. A linear guidance system, as set forth in claim 9, wherein provided at the through openings (7) of the ball cage (5) are elastically deformable holding means (15) which are of such a configuration that they secure the balls to prevent them from falling out of the through openings (7) in the direction of the running surface (9, 9'), arranged under the ball cage (5), of the guide rail, when the balls (4) do not bear against the running surface (9, 9').

11. A linear guidance system as set forth in claim 1 wherein the ball cage (5) is elastically deformable and is fixed to the guide rail (1).

12. A linear guidance system as set forth in claim 1 wherein the balls (4) are held by the ball cage (5) with a prestressing against the running surfaces (9, 9') of the guide rail.

10

13. A linear guidance system, as set forth in claim 1, wherein provided on the ball cage (5), is at least one torsion groove (13), in at least a longitudinal portion of the ball cage, which torsion groove (13) is arranged on a side of the ball cage (5) toward the running surfaces (9, 9') of the guide rail (1).

14. A linear guidance system as set forth in claim 1 wherein the ball cage is strip shaped and side edges (5', 5''), provided in a longitudinal extent (A) of the strip-shaped ball cage (5), engage into two grooves (6, 6') disposed in mutually opposite relationship in a longitudinal extent (B) of the guide rail (1) for securing the ball cage (5) to the guide rail.

15. A linear guidance system as set forth in claim 14 wherein the ball cage (5), on a side remote from the running surfaces (9, 9') of the guide rail (1), has a plurality of knob-shaped raised portions (14) arranged in succession in a row and in proximity of the side edges in the longitudinal extent of the ball cage (5).

16. A linear guidance system as set forth in claim 1 wherein the ball cage (5) is made from plastic material.

17. A linear guidance system as set forth in claim 1 wherein the guide rail (1) on two mutually opposite sides has respectively precisely one running surface (9, 9') and one ball bearing.

* * * * *