



US008570543B2

(12) **United States Patent**
Washington

(10) **Patent No.:** **US 8,570,543 B2**
(45) **Date of Patent:** **Oct. 29, 2013**

(54) **DEVICE AND METHOD FOR IMPROVING XEROGRAPHIC VOLTAGE UNIFORMITY FOR AN IMAGE RECORDING APPARATUS**

(75) Inventor: **John R. Washington**, Hitchin (GB)

(73) Assignee: **Xerox Corporation**, Norwalk, CT (US)

(*) Notice: Subject to any disclaimer, the term of this patent is extended or adjusted under 35 U.S.C. 154(b) by 291 days.

(21) Appl. No.: **13/028,703**

(22) Filed: **Feb. 16, 2011**

(65) **Prior Publication Data**

US 2012/0206738 A1 Aug. 16, 2012

(51) **Int. Cl.**

G06F 3/12 (2006.01)
H01J 1/62 (2006.01)

(52) **U.S. Cl.**

USPC **358/1.13**; 358/1.9; 358/474; 358/1.7;
347/19; 347/130; 347/237; 347/238; 313/500;
399/4

(58) **Field of Classification Search**

USPC 347/236, 237, 238, 239, 19; 313/500;
358/1.7, 1.9, 1.13, 296, 474
See application file for complete search history.

(56) **References Cited**

U.S. PATENT DOCUMENTS

4,727,428 A * 2/1988 Futatsugi et al. 358/296
4,967,211 A * 10/1990 Colby et al. 347/131
5,016,027 A * 5/1991 Uebbing 347/236
5,586,055 A * 12/1996 Ng et al. 702/90
5,666,150 A * 9/1997 Ajewole 347/240

5,668,587 A * 9/1997 Hammond et al. 347/237
5,917,535 A * 6/1999 Corona 347/238
6,223,006 B1 * 4/2001 Scheuer et al. 399/48
6,554,388 B1 * 4/2003 Wong et al. 347/19
6,982,813 B2 * 1/2006 Hirata et al. 358/1.9
7,253,828 B2 * 8/2007 Ng et al. 347/236
7,649,638 B2 * 1/2010 Beard et al. 358/1.13
2003/0007062 A1 * 1/2003 Wong et al. 347/236
2003/0116694 A1 * 6/2003 Maeda 250/205
2003/0117484 A1 * 6/2003 Vazan 347/236
2004/0100552 A1 * 5/2004 Taira et al. 347/236
2004/0183457 A1 * 9/2004 Kondo et al. 315/169.3
2004/0183886 A1 * 9/2004 Regelsberger et al. 347/130
2006/0023017 A1 * 2/2006 Ng et al. 347/19
2012/0140014 A1 * 6/2012 Hosier 347/236

* cited by examiner

Primary Examiner — Twyler Haskins

Assistant Examiner — Dennis Dicker

(74) Attorney, Agent, or Firm — Simpson & Simpson, PLLC

(57) **ABSTRACT**

An image recording apparatus including a memory element and a processor for a specially programmed general purpose computer. The memory element stores correction data for a plurality of locations on a photoreceptor for the image recording apparatus. The processor is for: inducing a charge on the photoconductive layer; receiving image data including, for said each location in the plurality of locations, a first or second desired voltage level; calculating, using the correction and image data, respective desired output power levels for a LED printbar for the apparatus, aligned with the plurality of locations, to discharge each location to the one of the first or second desired charge level, the respective desired output power levels selected to compensate for variances of respective induced charge levels at the plurality of locations; and supplying respective power inputs to the plurality of LEDs to generate the respective desired output power levels.

26 Claims, 5 Drawing Sheets

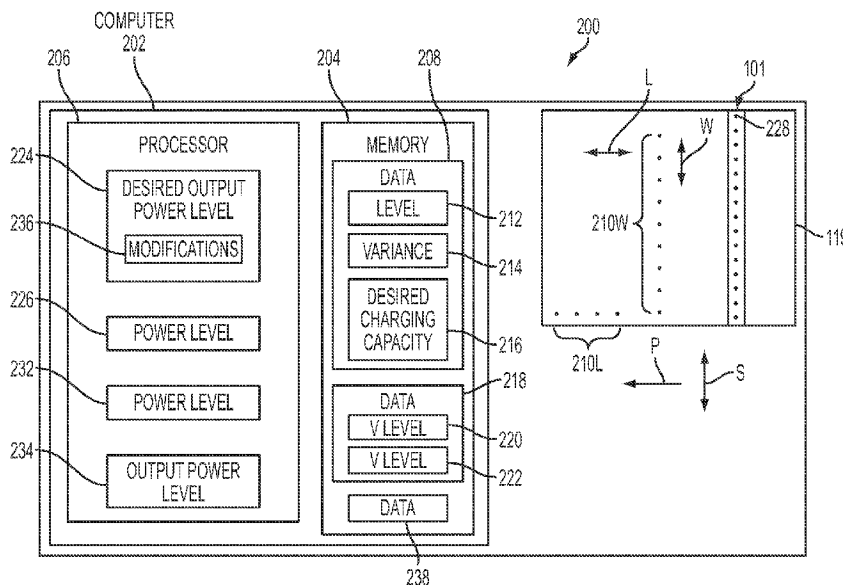

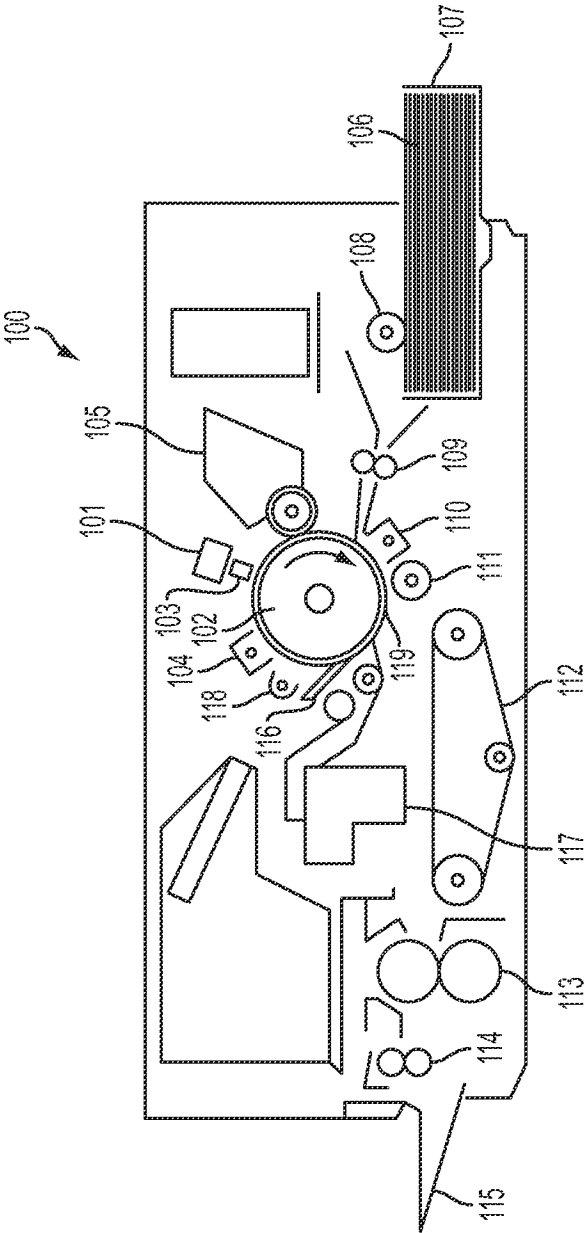

FIG. 1
PRIOR ART

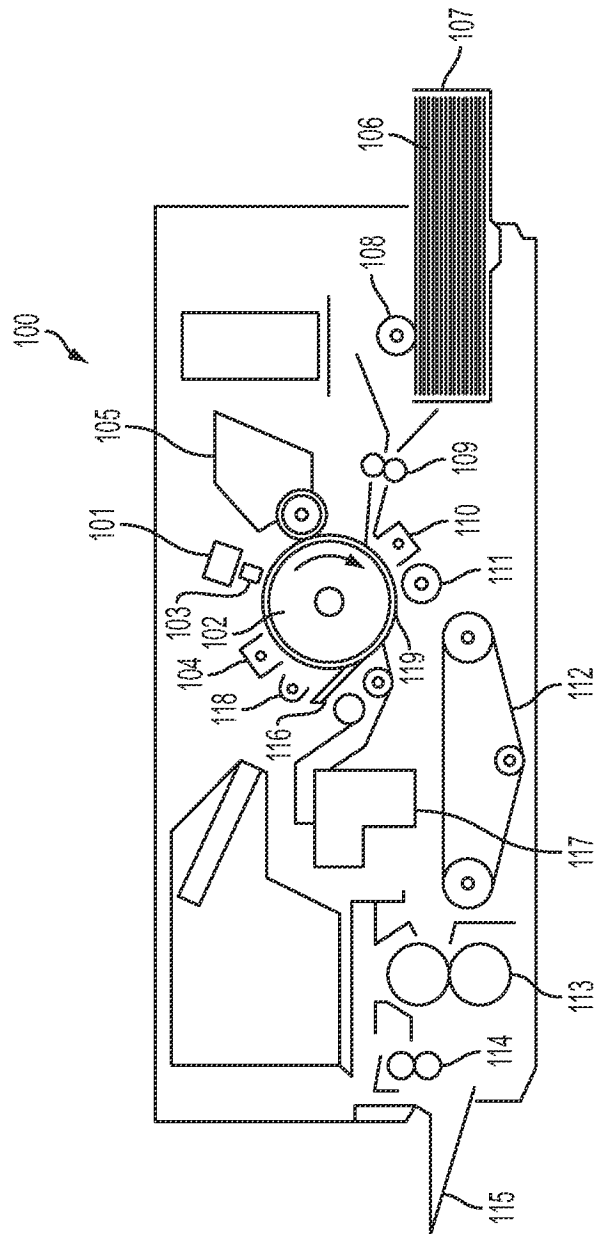

FIG. 2

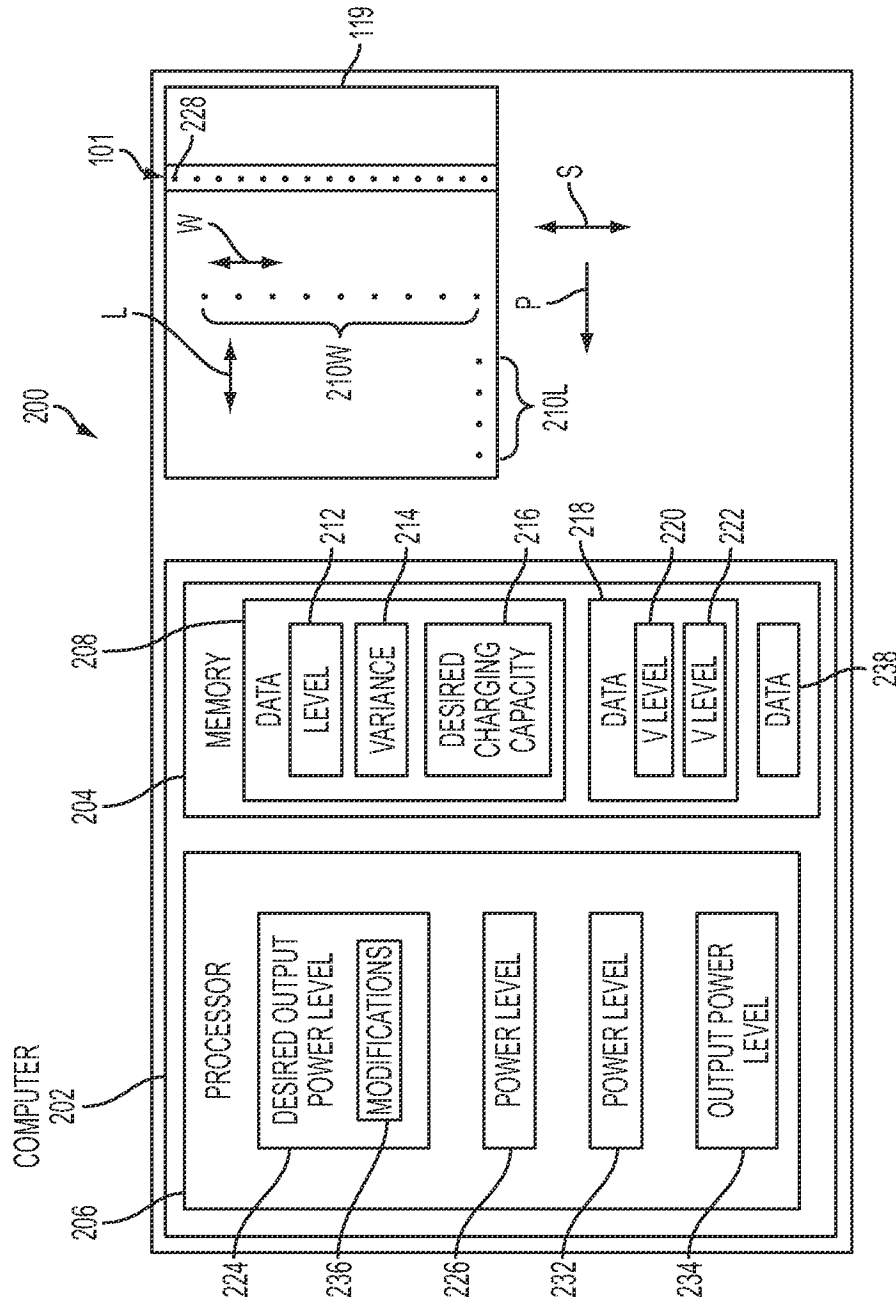

FIG. 3

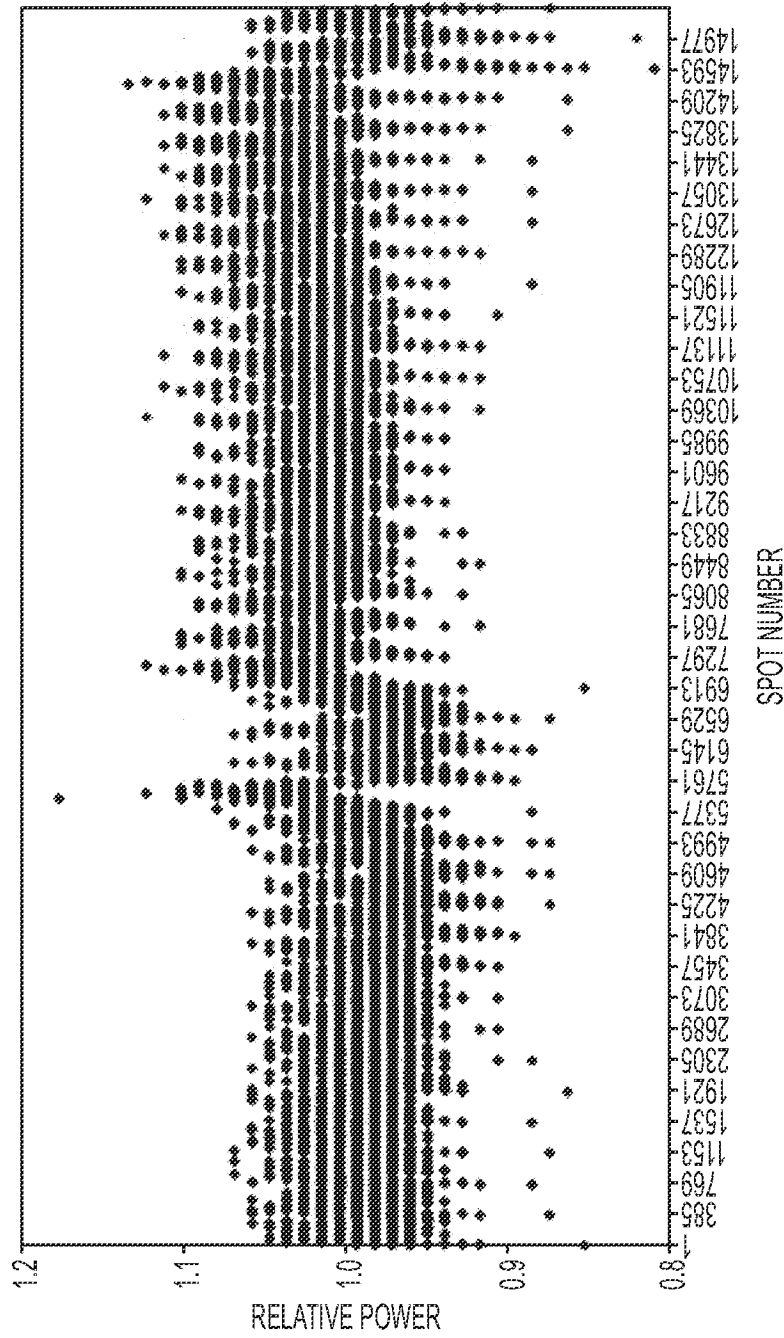

FIG. 4

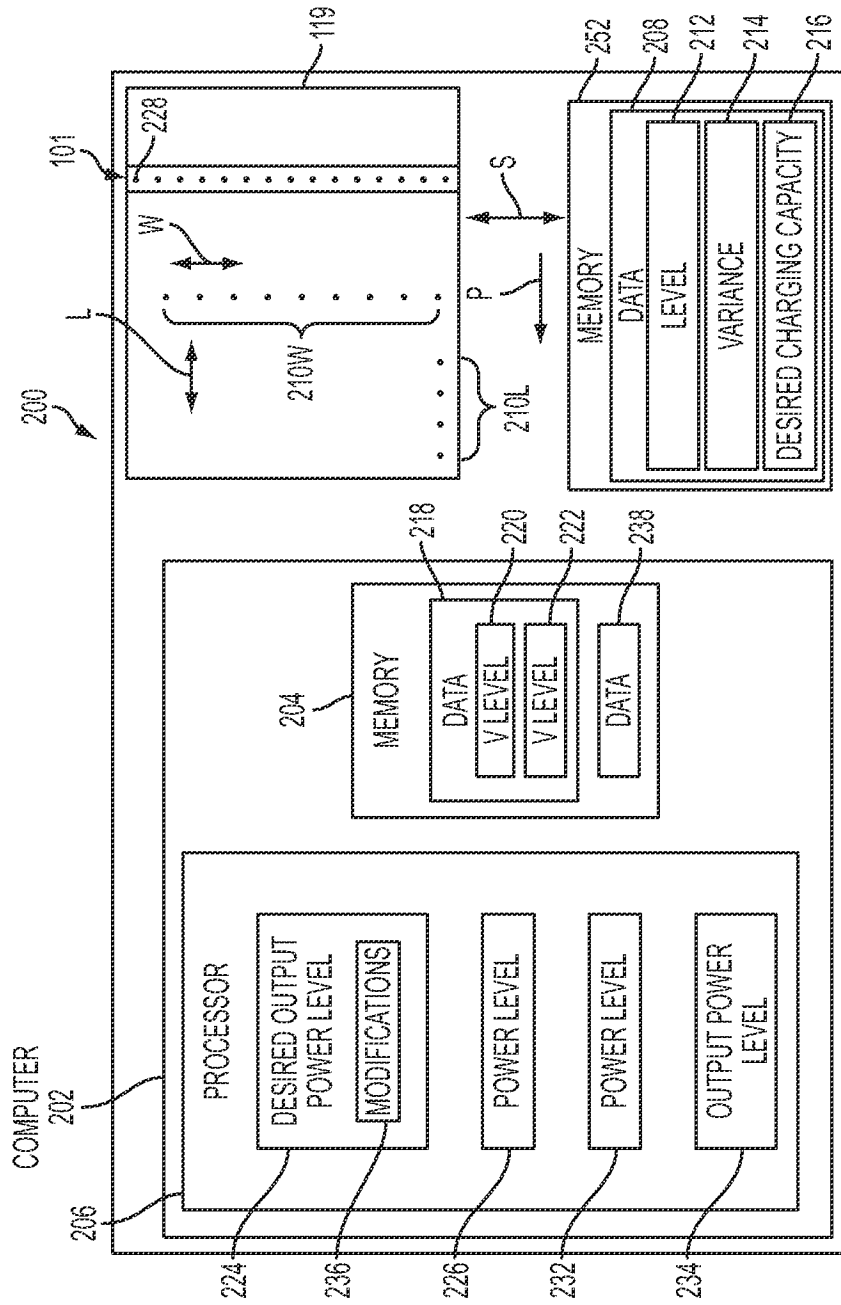

FIG. 5

DEVICE AND METHOD FOR IMPROVING XEROGRAPHIC VOLTAGE UNIFORMITY FOR AN IMAGE RECORDING APPARATUS

TECHNICAL FIELD

The present disclosure relates to an image recording apparatus with improved voltage uniformity for a photoreceptor, in particular, to an image recording device with control of power inputs to light-emitting diodes (LEDs) in an LED print-head to compensate for charge carrying variances for a photoconductive layer of the photoreceptor.

BACKGROUND

FIG. 1 schematically shows prior art image recording apparatus **100** with light-emitting diode (LED) printbar **101**. Printbar **101** is an example of an LED full width array imager. An LED full width array imager consists of an arrangement of a large number of closely spaced LEDs in a linear array. By providing relative motion between the LED printbar and a photoreceptor in a process direction, and by selectively energizing the LEDs at the proper times in a scan direction, a desired latent electrostatic image can be produced on the recording member. The production of a desired latent image is usually performed by having each LED expose a corresponding pixel on the recording member in accordance with image-defining video data information applied to the printbar through driver circuitry. Conventionally, digital data signals from a data source, which may be a Raster Input Scanner (RIS), a computer, a word processor or some other source of digitized image data is clocked into a shift register. Some time after the start of a line signal, individual LED drive circuits are then selectively energized to control the on/off timing of currents flowing through the LEDs. The LEDs selectively turn on and off at fixed intervals to form a line exposure pattern on the surface of the photoreceptor. A complete image is formed by successive line exposures.

The following provides further detail regarding prior art apparatus **100**. Printbar **101** includes: LED's controlled according to recording signals supplied from an unrepresented external device; a photoreceptor (in the form of a rotary drum) **102** provided with photoconductive layer **119** along the periphery thereof; a rod lens array **103** for focusing the light beams of the LED's in the printing head **101** onto photoconductive layer **119**; a corona charger **104** for charging photoconductive layer **119** in advance; a developing station **105** for developing an electrostatic latent image with toner; a recording sheet **106**; a cassette **107** housing a plurality of recording sheets **106**; a feed roller **108** for feeding the recording sheet **106** from the cassette **107**; registration rollers **109** for matching the front end of the recording sheet with the leading end of the image formed on the drum **102**; a transfer charger **110** for transferring the developed image from the drum **102** onto the recording sheet **106**; a separating roller **111** for separating the recording sheet from the drum **102**; a belt **112** for transporting the recording sheet; fixing rollers **113**; discharge rollers **114** for discharging the recording sheet onto a tray **115**; a blade cleaner **116** for removing the toner remaining on the drum **102**; a container **117** for the recovered toner; and a lamp **118** for eliminating charge remaining on the drum **102**.

In general, the LEDs in the printbar are operated so as to discharge respective portions of photoconductive layer **119** such that the respective voltage levels for the portions of the photoreceptor are at a first level corresponding to a print area or at a second level corresponding to a blank area. Toner

adheres to the photoreceptor according to the charge remaining on the photoconductive layer. Therefore, the first level is relatively high and the second level is relatively low. The operation of the LEDs assumes that the charge on the photoconductive layer, prior to illumination by the LEDs, is at a uniform specified level, in particular, across the width of the photoreceptor (orthogonal to the direction of movement for the photoreceptor). However, the actual charge on various portions of the photoconductive layer can vary from the specified level due to dimensional variances in the photoconductive layer, misalignment of charger **104**, or misalignment of drum **102**. Such variances in the actual charge levels result in the LEDs discharging the respective portions of the photoconductive layer at levels other than the first or second level noted above, which results in a degradation of print quality for apparatus **100**.

For example, the thickness of photoconductive layer **119** is assumed to be at a specified level. However, the actual thickness of the photoconductive layer, in particular, across the width of the photoreceptor, can vary due to fabrication tolerances. The charge carried by the photoconductive is directly related to the thickness of the photoconductive layer. For a particular charging voltage from charger **104**, there is an assumed charge on the photoreceptor in accordance with the assumed specified thickness of the photoconductive layer. However, the actual charge carried by the photoreceptor, in response to the uniform charging voltage, can vary according to the actual thickness of the photoconductive layer, which can vary from the specified thickness as noted above. For example, if the actual thickness of the photoconductive layer varies from the assumed thickness such that the charge on a portion of the photoconductive layer is greater than the assumed charge, the LED printbar will not be able to discharge the portion to the first or second level noted above. In this case, the image for the portion may be undesirably darker than surrounding areas.

Regarding the misalignment of charger **104**, for example, the distance of the charger from the photoreceptor can vary across the width of the photoreceptor due to the misplacement of the charger or deformations in the structure of the charger. The amount of charging voltage delivered to the photoreceptor depends on the distance between the charger and the photoreceptor. Therefore, the charge on the photoreceptor can vary as the distance between the charger and the photoreceptor varies. Drum misalignment can cause the distance between photoreceptor and the charger to vary along the length of the photoreceptor (along the direction of movement for the photoreceptor). It should be understood that the discussion above is applicable to image recording apparatus with other photoreceptor configurations, such as a photoreceptor belt. For example, misalignment of one or more drums for a photoreceptor belt can cause the drum alignment problems noted above.

U.S. Pat. No. 6,223,006 describes photoreceptor charge control directed toward photoreceptor variation around a periphery of a photoreceptor due to the manufacturing process for the photoreceptor. This patent fails to address variation in areas of the photoreceptor other than along the periphery, for example, variation across a width of the photoreceptor. This patent also fails to address variation due to alignment of the photoreceptor or components acting on the photoreceptor, such as the charger.

SUMMARY

According to aspects illustrated herein, there is provided a method for improving xerographic voltage uniformity in an

3

image recording apparatus, including: storing, in a memory element for at least one specially programmed general purpose computer, correction data for a plurality of locations on a photoconductive layer of a photoreceptor for the image recording apparatus; inducing a charge, using a processor for the at least one specially programmed general purpose computer, on the photoconductive layer; receiving, using the processor, image data for producing an image using the apparatus, the image data including, for said each location in the plurality of locations, one of a first or second desired voltage level; calculating, using the processor, the correction data, and the image data, respective desired output power levels for a plurality of light emitting diodes (LEDs) in a printbar for the apparatus, aligned with the plurality of locations, to discharge said each location to the one of the first or second desired charge level, the respective desired output power levels selected to compensate for variances of respective induced charge levels at the plurality of locations; and supplying, using the processor, respective power inputs to the plurality of LEDs to generate the respective desired output power levels.

According to aspects illustrated herein, there is provided a method for improving xerographic voltage uniformity in an image recording apparatus, including: storing, in a memory element for at least one specially programmed general purpose computer, correction data for a plurality of locations across a width of a photoconductive layer for a photoreceptor for the image recording apparatus, the correction data including respective variances, with respect to a desired induced charge level, of respective actual induced charge levels; applying, using a processor for the at least one specially programmed general purpose computer, voltage to the photoconductive layer such that the respective actual induced charge levels differ from the desired induced charge level according to the respective variances; receiving, using the processor, image data including respective desired charge levels for the plurality of locations, the respective desired charge levels being one of a second or third charge level; storing, in the memory element, respective output power levels, for a plurality of light emitting diodes (LEDs) in a printbar for the apparatus, the plurality of LEDs aligned with the plurality of locations; determining, using the processor, the stored respective output power levels, and the correction and image data, that the respective output power levels for the plurality of LEDs are insufficient to discharge the plurality of locations to be within a first range of the second desired charge level or to be within a second range of the third desired charge level; and modifying, using the processor and the correction and image data, power supplied to the plurality of LEDs such that the respective output power levels of the plurality of LEDs are sufficient to discharge the plurality of locations to be within the first range of the second desired charge level or to be within the second range of the third desired charge level.

According to aspects illustrated herein, there is provided a method for improving xerographic voltage uniformity using a module installable in and removable from an image recording apparatus, including: storing, in a memory element for the module, correction data for a plurality of locations on a photoconductive layer of a photoreceptor included in the module; installing the module in the image recording apparatus; inducing a charge, using a processor for at least one specially programmed general purpose computer, on the photoconductive layer; receiving, using the processor, image data for producing an image using the apparatus, the image data including, for said each location in the plurality of locations, one of a first or second desired voltage level; calculating, using the processor, the correction data, and the image data, respective

4

desired output power levels for a plurality of light emitting diodes (LEDs) in a printbar for the apparatus, aligned with the plurality of locations, to discharge said each location to the one of the first or second desired charge level, the respective desired output power levels selected to compensate for variances of respective induced charge levels at the plurality of locations; and supplying, using the processor, respective power inputs to the plurality of LEDs to generate the respective desired output power levels.

According to aspects illustrated herein, there is provided an image recording apparatus with improved xerographic voltage uniformity, including a memory element and a processor for at least one specially programmed general purpose computer. The memory element is for storing correction data for a plurality of locations on a photoconductive layer of a photoreceptor for the image recording apparatus. The processor is for: inducing a charge on the photoconductive layer; receiving image data for producing an image using the apparatus, the image data including, for said each location in the plurality of locations, one of a first or second desired voltage level; calculating, using the correction data and the image data, respective desired output power levels for a plurality of light emitting diodes (LEDs) in a printbar for the apparatus, aligned with the plurality of locations, to discharge said each location to the one of the first or second desired charge level, the respective desired output power levels selected to compensate for variances of respective induced charge levels at the plurality of locations; and supplying respective power inputs to the plurality of LEDs to generate the respective desired output power levels.

According to aspects illustrated herein, there is provided an image recording apparatus with improved xerographic voltage uniformity, including a memory element and a processor for at least one specially programmed general purpose computer. The memory element is for: storing correction data for a plurality of locations across a width of a photoconductive layer for a photoreceptor for the image recording apparatus, the correction data including respective variances, with respect to a desired induced charge level, of respective actual induced charge levels; and storing respective light output levels, for a plurality of light emitting diodes (LEDs) in a printbar for the apparatus, the plurality of LEDs aligned with the plurality of locations. The processor is for: applying voltage to the photoconductive layer such that the respective actual induced charge levels differ from the desired induced charge level according to the respective variances; receiving image data including respective desired charge levels for the plurality of locations, the respective desired charge levels being one of a second or third charge level; determining, using the stored respective light output levels and the correction and image data, that the respective output power levels for the plurality of LEDs are insufficient to discharge the plurality of locations to be within a first range of the second desired charge level or to be within a second range of the third desired charge level; and modifying, using the correction and image data, power supplied to the plurality of LEDs such that the respective output power levels of the plurality of LEDs are sufficient to discharge the plurality of locations to be within the first range of the second desired charge level or to be within the second range of the third desired charge level.

According to aspects illustrated herein, there is provided a module for an image recording apparatus, including: a photoreceptor with a photoconductive layer; and a memory element for storing correction data for a plurality of locations on the photoconductive layer of the photoreceptor. The module is insertable into and removable from the image recording apparatus. When the module is installed in the apparatus, a

processor for at least one specially programmed general purpose computer is for: inducing a charge on the photoconductive layer; receiving image data for producing an image using the apparatus, the image data including, for said each location in the plurality of locations, one of a first or second desired voltage level; calculating, using the correction data and the image data, respective desired output power levels for a plurality of light emitting diodes (LEDs) in a printbar for the apparatus, aligned with the plurality of locations, to discharge said each location to the one of the first or second desired charge level, the respective desired output power levels selected to compensate for variances of respective induced charge levels at the plurality of locations; and supplying respective power inputs to the plurality of LEDs to generate the respective desired output power levels.

BRIEF DESCRIPTION OF THE DRAWINGS

Various embodiments are disclosed, by way of example only, with reference to the accompanying schematic drawings in which corresponding reference symbols indicate corresponding parts, in which:

FIG. 1 schematically shows a prior art image recording apparatus with a light-emitting diode (LED) printbar;

FIG. 2 schematically shows an image recording apparatus with an LED printbar and improved xerographic voltage uniformity;

FIG. 3 is a schematic block diagram of the apparatus shown in FIG. 2;

FIG. 4 is a graph illustrating power variability for LEDs in an LED printbar; and,

FIG. 5 is a schematic block diagram of the apparatus shown in FIG. 2 with a module.

DETAILED DESCRIPTION

Furthermore, as used herein, the words “printer,” “printer system”, “printing system”, “printer device” and “printing device” as used herein encompasses any apparatus, such as a digital copier, bookmaking machine, facsimile machine, multi-function machine, etc. which performs a print outputting function for any purpose.

By “photoconductive layer” we mean an outermost layer of a photoreceptor, positioned over a substrate of the photoreceptor, which holds an induced electrostatic charge. A photoconductive layer acts as an insulator when not exposed to light and acts as a conductor when exposed to light. When the photoreceptor is charged, a positive or negative charge is created on the surface of the photoconductive layer. When the charged surface of the photoconductive layer is exposed to light, the layer acts as a conductor and the positive charge is at least partially discharged or neutralized according to the intensity of the light.

Moreover, although any methods, devices or materials similar or equivalent to those described herein can be used in the practice or testing of these embodiments, some embodiments of methods, devices, and materials are now described.

FIG. 2 schematically shows image recording apparatus 200 with an LED printbar and improved xerographic voltage uniformity.

FIG. 3 is a schematic block diagram of apparatus 200 shown in FIG. 2. The following should be viewed in light of FIGS. 2 and 3. Apparatus 200 can be for black and white imaging or for color imaging. The description of the components and operations for apparatus 100 in FIG. 1 are applicable to apparatus 200 except as discussed below. Apparatus 200 differs from apparatus 100 at least by computer 200 and

the functions and operations associated with computer 202 as discussed infra. Apparatus 200 includes at least one specially programmed computer 202 with memory element 204 and processor 206. The memory element stores correction data 208 for plurality of locations 210 on the photoreceptor 102, for example on photoconductive layer 119. In an example embodiment, the locations, for example, locations 210W are along width W of the photoreceptor, orthogonal to process direction P for the apparatus. In an example embodiment, the locations, for example, locations 210L are along length L of the photoreceptor, parallel to process direction P. It should be understood that respective example numbers, configurations, and spacings of locations 210 are shown in the figures for purposes of illustration only and that other numbers, configurations, or spacings of locations 210 are possible.

The discussion that follows is directed to the configuration shown in FIG. 2, specifically, to an image recording apparatus with a drum photoreceptor, such as drum 102. However, it should be understood that the discussion is applicable to any photoreceptor configuration known in the art, for example, a belt photoreceptor.

In an example embodiment, data 208 includes actual induced charge levels 212 for locations 210 and variances 214 of actual induced charge levels 212 from desired induced charge level 216 for the photoreceptor. Data 208 can be obtained by any means known in the art. As noted supra, the actual induced charge level of photoconductive layer 119 is dependent upon the thickness of the layer, the orientation of the charger, and the orientation of drum 102. In an example embodiment, as part of the fabrication process for photoreceptor 102, variations in the thickness of the photoconductive layer coating occur across width W, for example, at locations 210W. Using the actual thickness of the photoconductive layer, levels 212 and variances 214 are measured or determined for locations 210.

In an example embodiment, locations 210 are along width W, variances 214 are due to the misalignment of the charger noted supra, and variances 214 are determined by any means known in the art. For example, the photoreceptor is charged in the apparatus, induced charge voltage measurements are taken at locations 210, and the measured charge voltages are compared with desired induced charge level 216 to calculate the variances.

In an example embodiment, locations 210 are along length L, variances 214 are due to the misalignment of drum 102 noted supra, and variances 214 are determined by any means known in the art. For example, the photoreceptor is charged in the apparatus, induced charge voltage measurements are taken at locations 210, and the measured charge voltages are compared with desired induced charge level 216 to calculate the variances. In the discussion that follows, it is assumed that locations 210 are along width W and that respective levels 212 and variances 214 are uniform along length L of the photoreceptor for a particular location along the width of the photoreceptor.

In an example embodiment, as part of an operation to produce an image using apparatus 200, the processor and the charger charge the photoreceptor. In general, the charger supplies a charge voltage according to the desired induced charge level 216, for example, the charging voltage results in photoconductive layer 119 being charged at desired induced charge level 216 when the thickness of the coating on photoconductive layer 119 is equal to the specified thickness noted supra. As noted above, the actual induced charge levels may vary, for example, as recorded in data 208.

The processor receives image data 218 for producing the image. Data 218 includes, for each location 210 and for a scan

line in scan direction S, desired voltage level **220** or desired voltage level **222**. Voltage levels **220** and **222** are voltage levels to which locations **210** are to be discharged by the LEDs. For example, voltage level **220** is the voltage level for a printed portion of the image and voltage level **222** is the voltage level for a blank portion of the image. In an example embodiment, the voltages at the locations are discharged to within respective ranges of voltage levels **220** or **222**.

The processor calculates, using data **208** and **218**, desired output power levels **224** for LEDs **226** in the printbar, aligned with locations **210**, to discharge each location **210** to voltage level **220** or **222** as specified by data **218**. Output power levels **224** are compensated according to variances **214** as further described infra. The processor calculates power levels **226** for power inputs to LEDs **228** to generate output power levels **224**. An exemplary number of LEDs **228** are shown for purposes of illustration only. It should be understood that apparatus **200** is not limited to the number of LEDs shown.

In an example embodiment, the processor is for calculating, assuming that locations **210** are charged at desired induced charge level **216**, power levels **232** for the power inputs for the LEDs as required to produce output power levels **234** from the plurality of LEDs to discharge locations **210** to one of charge levels **220** or **222**. That is, the processor calculates the “base” condition assuming uniform charging of photoconductive layer **119**. The processor calculates, using data **208** and **218**, modifications **236** to output power levels **224** to discharge locations **210** to one of charge levels **220** or **222** given variances **214**. The processor uses modifications **236** to modify power levels **232** to create power levels **226**. That is, the processor modifies the “base” power inputs.

In an example embodiment, in the “base” condition apparatus **200** supplies power to the LEDs at one substantially uniform level for locations with voltage level **220** and at another substantially uniform level for locations with voltage level **222**. For example, for a location **210** with variance **214** of 25V from a desired induced charge level **216** of 500V, the processor determines an increase in output power for the LED aligned with the location to discharge the additional 25V. The processor calculates an increase to the substantially uniform power level for locations with voltage level **220** or to the substantially uniform power level for locations with voltage level **222** as needed to generate the increase in output power.

FIG. 4 is a graph illustrating power variability for LEDs in an LED printbar. The following should be viewed in light of FIGS. 2 through 4. In an example embodiment, using any means known in the art, the memory element stores data **238** regarding variances in the power and light outputs for the LEDs. That is, data **238** includes actual output power levels for the LEDs. Such variances can be caused by the following factors. During early life most LEDs increase in power as they “anneal” and then exponentially drop in time. Thus, for individual LEDs, power will vary with time with an increase initially followed by a long slow degradation. It is commonly understood that the degradation is mainly dependent on the total usage (time×duty cycle) of the LEDs and current level, with some variation from batch to batch due to semiconductor processing. The processor uses data **238** to compensate for variances in the output power of LEDs **228** by modifying power inputs to the LEDs. For example, if data **238** shows that the output power level for a particular LED is less than a certain threshold, processor **206** increases the input power to the LED to boost the output power level to the threshold. The processor uses data **238** to compensate for variances **214** as discussed infra.

In an example embodiment, the processor calculates, using data **238**, power levels **226** for the power inputs to the

LEDs as required to produce desired output power levels **234** (the output power levels needed to discharge respective locations **210** given variances **214**). That is, rather than making input power corrections assuming a uniform output power level for the LEDs in the plurality of LEDs, the processor uses the actual output power levels for the LEDs as recorded in data **238**. For example, voltage level **220** is 500V and is the voltage level for a printed portion of the image, and voltage level **222** is 100V and is the voltage level for a blank portion of the image. Variance **214** for two particular locations **210** is 25V. Thus, the induced charges on the particular locations, prior to being discharged by the LEDs, are 525V. From data **238**, the processor determines that the actual output power level of the first LED is sufficient to discharge the first location only to 520V and the actual power level of the second LED is sufficient to discharge the second location only to 515V. Thus, the output power levels of the LEDs must be boosted to properly discharge the locations.

The processor calculates, using data **238**, respective output power level increases needed by the two LEDs to discharge the two locations to 500V (the first LED requires a greater increase in output power than the second LED) and calculates the respective modifications to the respective power inputs for the two LEDs needed to generate the respective increases in output power level.

FIG. 5 is a schematic block diagram of the apparatus shown in FIG. 2 with module **250**. The respective descriptions for FIGS. 2 and 3 are applicable to FIG. 5 except as noted below. U.S. Pat. No. 7,649,638, the disclosure of which is incorporated herein by reference in its entirety, discloses a customer replaceable unit, or module, including a memory element for storing information regarding operation or characteristics of the module. In an example embodiment, apparatus **200** includes module **250** with memory element **252**. In an example embodiment, module **250** includes photoreceptor **119**. Module **250** can be installed in or removed from apparatus **200**. For example, the module can be installed in a particular apparatus **200** and then removed from the particular apparatus for reinstallation in the same apparatus or for installation in a different apparatus **200**. Memory element **252** includes data **208**. The discussion supra regarding memory **204**, data **208**, and photoreceptor **119** is applicable to apparatus **200** with module **250**. For example, processor **206** carries out the operations described supra for the processor, for example, operations using data **208**, using module **250**.

It will be appreciated that various of the above-disclosed and other features and functions, or alternatives thereof, may be desirably combined into many other different systems or applications. Various presently unforeseen or unanticipated alternatives, modifications, variations, or improvements therein may be subsequently made by those skilled in the art which are also intended to be encompassed by the following claims.

What is claimed is:

1. A computer-based method for improving xerographic voltage uniformity in an image recording apparatus, comprising:
 - storing, in a memory element for at least one specially programmed general purpose computer, correction data for a plurality of locations on a photoconductive layer of a photoreceptor for the image recording apparatus;
 - inducing a charge, using a processor for the at least one specially programmed general purpose computer, on the photoconductive layer;
 - receiving, using the processor, image data for producing an image using the apparatus, the image data including, for

9

said each location in the plurality of locations, one of a first or second desired voltage level;

calculating, using the processor, the correction data, and the image data, respective desired output power levels for a plurality of light emitting diodes (LEDs) in a printbar for the apparatus, aligned with the plurality of locations, to discharge said each location to the one of the first or second desired charge level, the respective desired output power levels selected to compensate for variances of respective induced charge levels at the plurality of locations; and,

supplying, using the processor, respective power inputs to the plurality of LEDs to generate the respective desired output power levels.

2. The computer-based method of claim 1 wherein the correction data includes, for each location in the plurality of locations, a respective variance, with respect to a desired induced charge level for the photoconductive layer, of a respective actual induced charge level.

3. The computer-based method of claim 1 wherein: the first desired charge level is for a print area for the image; and, the second desired charge level is for a blank area for the image.

4. The computer-based method of claim 1 wherein: the plurality of locations on the photoreceptor is across a width, orthogonal to a process direction, of the photosensor; or, the plurality of locations on the photoreceptor is along a length, parallel to a process direction, of the photosensor.

5. The computer-based method of claim 1 wherein a thickness of the photoconductive coating is different at said each location.

6. A computer-based method for improving xerographic voltage uniformity in an image recording apparatus, comprising: storing, in a memory element for at least one specially programmed general purpose computer, correction data for a plurality of locations across a width of a photoconductive layer for a photoreceptor for the image recording apparatus, the correction data including respective variances, with respect to a desired induced charge level, of respective actual induced charge levels;

applying, using a processor for the at least one specially programmed general purpose computer, voltage to the photoconductive layer such that the respective actual induced charge levels differ from the desired induced charge level according to the respective variances;

receiving, using the processor, image data including respective desired charge levels for the plurality of locations, the respective desired charge levels being one of a second or third charge level;

storing, in the memory element, respective output power levels for a plurality of light emitting diodes (LEDs) in a printbar for the apparatus, the plurality of LEDs aligned with the plurality of locations;

determining, using the processor, the stored respective output power levels, and the correction and image data, that the respective output power levels for the plurality of LEDs are insufficient to discharge the plurality of locations to be within a first range of the second desired charge level or to be within a second range of the third desired charge level; and,

modifying, using the processor and the correction and image data, power supplied to the plurality of LEDs such that the respective output power levels of the plurality of

10

LEDs are sufficient to discharge the plurality of locations to be within the first range of the second desired charge level or to be within the second range of the third desired charge level.

7. The computer-based method of claim 6 wherein: the first desired charge level is for a print area for the image; and, the second desired charge level is for a blank area for the image.

8. The computer-based method of claim 6 wherein a thickness of the photoconductive coating is different at each location in the plurality of locations.

9. A computer-based method for improving xerographic voltage uniformity using a module installable in and removable from an image recording apparatus, comprising: storing, in a memory element for the module, correction data for a plurality of locations on a photoconductive layer of a photoreceptor included in the module; installing the module in the image recording apparatus; inducing a charge, using a processor for at least one specially programmed general purpose computer, on the photoconductive layer;

receiving, using the processor, image data for producing an image using the apparatus, the image data including, for said each location in the plurality of locations, one of a first or second desired voltage level;

calculating, using the processor, the correction data, and the image data, respective desired output power levels for a plurality of light emitting diodes (LEDs) in a printbar for the apparatus, aligned with the plurality of locations, to discharge said each location to the one of the first or second desired charge level, the respective desired output power levels selected to compensate for variances of respective induced charge levels at the plurality of locations; and,

supplying, using the processor, respective power inputs to the plurality of LEDs to generate the respective desired output power levels.

10. The computer-based method of claim 9 wherein the correction data includes, for each location in the plurality of locations, a respective variance, with respect to a desired induced charge level for the photoconductive layer, of a respective actual induced charge level.

11. The computer-based method of claim 9 wherein: the first desired charge level is for a print area for the image; and, the second desired charge level is for a blank area for the image.

12. The computer-based method of claim 9 wherein: the plurality of locations on the photoreceptor is across a width, orthogonal to a process direction, of the photosensor; or, the plurality of locations on the photoreceptor is along a length, parallel to a process direction, of the photosensor.

13. The computer-based method of claim 9 wherein a thickness of the photoconductive coating is different at said each location.

14. An image recording apparatus with improved xerographic voltage uniformity, comprising: a memory element for at least one specially programmed general purpose computer for storing correction data for a plurality of locations on a photoconductive layer of a photoreceptor for the image recording apparatus; and, a processor for the at least one specially programmed general purpose computer for: inducing a charge on the photoconductive layer;

11

receiving image data for producing an image using the apparatus, the image data including, for said each location in the plurality of locations, one of a first or second desired voltage level;

calculating, using the correction data and the image data, 5
respective desired output power levels for a plurality of light emitting diodes (LEDs) in a printbar for the apparatus, aligned with the plurality of locations, to discharge said each location to the one of the first or second desired charge level, the respective desired 10
output power levels selected to compensate for variances of respective induced charge levels at the plurality of locations; and,

supplying respective power inputs to the plurality of LEDs to generate the respective desired output power 15
levels.

15. The apparatus of claim 14 wherein the correction data includes, for each location in the plurality of locations, a respective variance, with respect to a desired induced charge level for the photoconductive layer, of a respective actual induced charge level. 20

16. The apparatus of claim 14, wherein:

the first desired charge level is for a print area for the image; 25
and,

the second desired charge level is for a blank area for the image.

17. The computer-based method of claim 14 wherein:

the plurality of locations on the photoreceptor is across a width, orthogonal to a process direction, of the photo- 30
sensor; or,

the plurality of locations on the photoreceptor is along a length, parallel to a process direction, of the photosen- 35
sor.

18. The computer-based method of claim 14 wherein a thickness of the photoconductive coating is different at said each location. 40

19. An image recording apparatus with improved xerographic voltage uniformity, comprising:

a memory element for at least one specially programmed general purpose computer for: 45

storing correction data for a plurality of locations across a width of a photoconductive layer for a photoreceptor for the image recording apparatus, the correction data including respective variances, with respect to a desired induced charge level, of respective actual induced charge levels; and, 50

storing respective output power levels, for a plurality of light emitting diodes (LEDs) in a printbar for the apparatus, the plurality of LEDs aligned with the plurality of locations; and, 55

a processor for the at least one specially programmed computer for:

applying voltage to the photoconductive layer such that the respective actual induced charge levels differ from the desired induced charge level according to the respective variances; 60

receiving image data including respective desired charge levels for the plurality of locations, the respective desired charge levels being one of a second or third charge level;

determining, using the stored respective output power levels and the correction and image data, that the respective output power levels for the plurality of LEDs are insufficient to discharge the plurality of locations to be within a first range of the second

12

desired charge level or to be within a second range of the third desired charge level; and,

modifying, using the correction and image data, power supplied to the plurality of LEDs such that the respective output power levels of the plurality of LEDs are sufficient to discharge the plurality of locations to be within the first range of the second desired charge level or to be within the second range of the third desired charge level.

20. The apparatus of claim 19, wherein:

the first desired charge level is for a print area for the image; 25
and,

the second desired charge level is for a blank area for the image.

21. The apparatus of claim 19 wherein a thickness of the photoconductive coating is different at each location in the plurality of locations. 30

22. A module for an image recording apparatus, comprising:

a photoreceptor with a photoconductive layer; and,

a memory element for storing correction data for a plurality of locations on the photoconductive layer of the photo- 35
receptor, wherein:

the module is insertable into and removable from the image recording apparatus; and, 40

when the module is installed in the image recording apparatus, a processor for at least one specially programmed general purpose computer is for:

inducing a charge on the photoconductive layer;

receiving image data for producing an image using the apparatus, the image data including, for said each location in the plurality of locations, one of a first or second desired voltage level; 45

calculating, using the correction data and the image data, respective desired output power levels for a plurality of light emitting diodes (LEDs) in a printbar for the apparatus, aligned with the plurality of locations, to discharge said each location to the one of the first or second desired charge level, the respective desired output power levels selected to compensate for variances of respective induced charge levels at the plurality of locations; and, 50

supplying respective power inputs to the plurality of LEDs to generate the respective desired output power levels.

23. The apparatus of claim 22 wherein the correction data includes, for each location in the plurality of locations, a respective variance, with respect to a desired induced charge level for the photoconductive layer, of a respective actual induced charge level. 55

24. The apparatus of claim 22, wherein:

the first desired charge level is for a print area for the image; 60
and,

the second desired charge level is for a blank area for the image.

25. The computer-based method of claim 22 wherein:

the plurality of locations on the photoreceptor is across a width, orthogonal to a process direction, of the photo- 65
sensor; or,

the plurality of locations on the photoreceptor is along a length, parallel to a process direction, of the photosen- 70
sor.

26. The computer-based method of claim 22 wherein a thickness of the photoconductive coating is different at said each location.