



US008844690B2

(12) **United States Patent**  
**Lindemann et al.**

(10) **Patent No.:** **US 8,844,690 B2**  
(45) **Date of Patent:** **Sep. 30, 2014**

(54) **PISTON SEAL WITH CENTERING WASHER**

USPC ..... 192/3.29; 192/110 R

(75) Inventors: **Patrick M. Lindemann**, Wooster, OH (US); **Brian C. Zaugg**, Wooster, OH (US); **Nathan Yensho**, Norton, OH (US); **Alfredo Jimenez**, Wooster, OH (US)

(58) **Field of Classification Search**

USPC ..... 192/3.28-3.3  
See application file for complete search history.

(73) Assignee: **Schaeffler Technologies GmbH & Co. KG**, Herzogenaurach (DE)

(56) **References Cited**

U.S. PATENT DOCUMENTS

(\* ) Notice: Subject to any disclaimer, the term of this patent is extended or adjusted under 35 U.S.C. 154(b) by 416 days.

6,561,330 B2 5/2003 Maienschein et al.  
6,948,602 B2 \* 9/2005 Arhab et al. .... 192/3.29  
7,513,346 B2 \* 4/2009 Degler et al. .... 192/3.3  
8,135,525 B2 \* 3/2012 Swank et al. .... 701/69

\* cited by examiner

(21) Appl. No.: **13/238,213**

*Primary Examiner* — Jacob S Scott

(22) Filed: **Sep. 21, 2011**

(74) *Attorney, Agent, or Firm* — Simpson & Simpson, PLLC

(65) **Prior Publication Data**

US 2012/0073926 A1 Mar. 29, 2012

**Related U.S. Application Data**

(60) Provisional application No. 61/385,678, filed on Sep. 23, 2010.

(57) **ABSTRACT**

A torque converter, including: a piston plate for a lock-up clutch, the piston plate including a circumferential surface forming an opening axially aligned with an axis of rotation for the torque converter; a ring-shaped element fixedly secured to the piston plate; and a seal in compressive engagement with the circumferential surface, axially aligned with the ring-shaped element, and including a surface facing radially inward for forming a seal with an input shaft inserted into the torque converter.

(51) **Int. Cl.**  
**F16H 45/02** (2006.01)

(52) **U.S. Cl.**  
CPC ..... **F16H 45/02** (2013.01); **F16H 2045/0294** (2013.01); **F16H 2045/0205** (2013.01); **F16H 2045/0221** (2013.01)

**18 Claims, 6 Drawing Sheets**

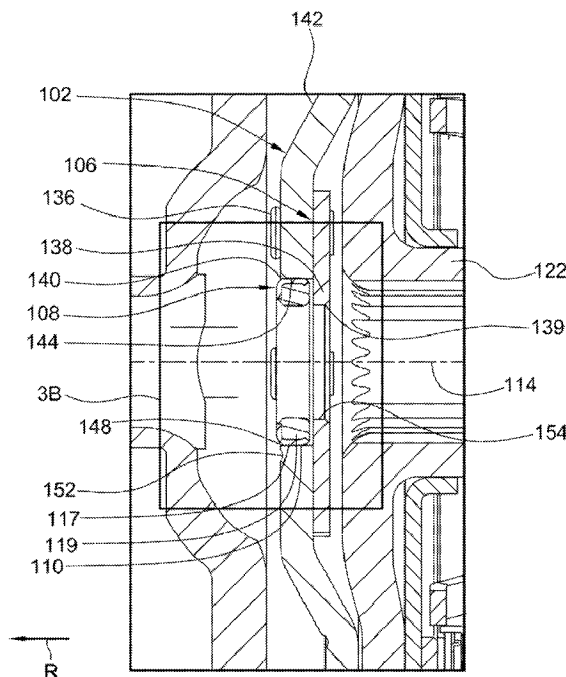

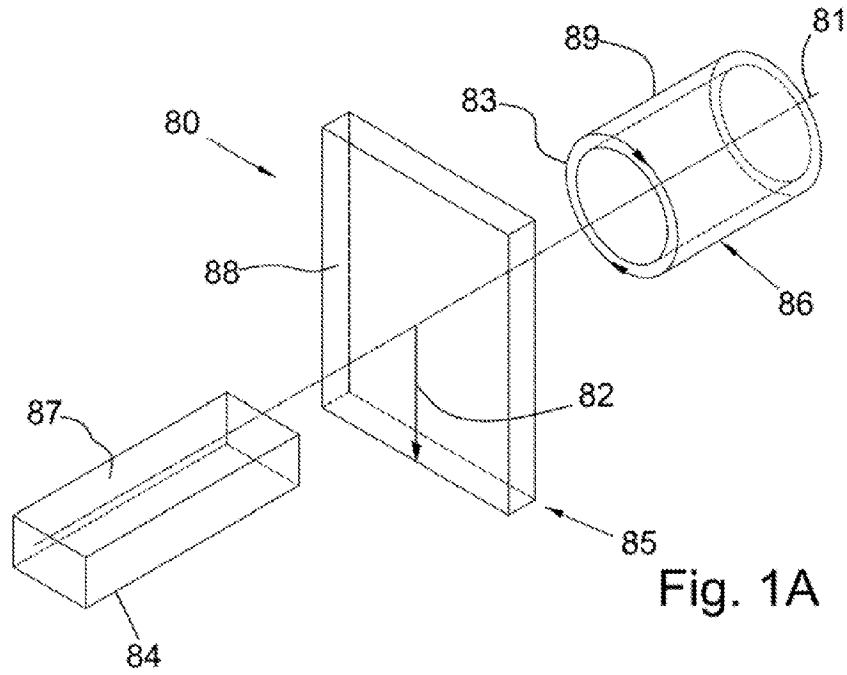

Fig. 1A

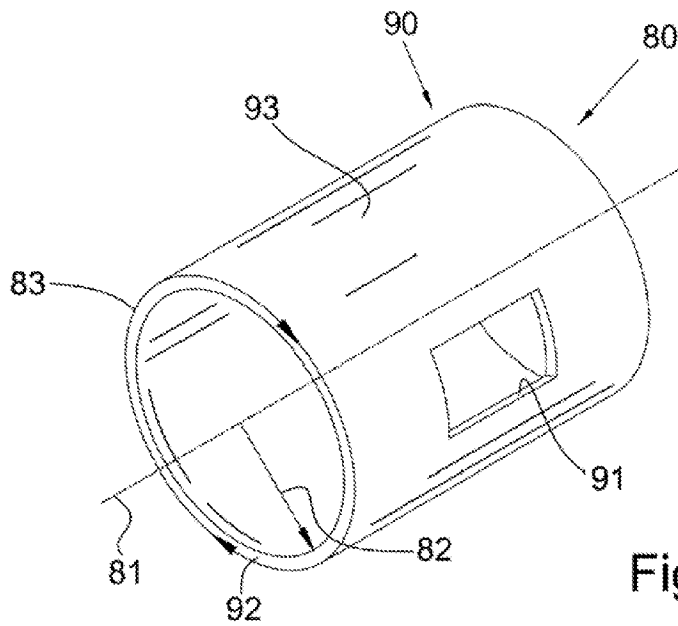

Fig. 1B

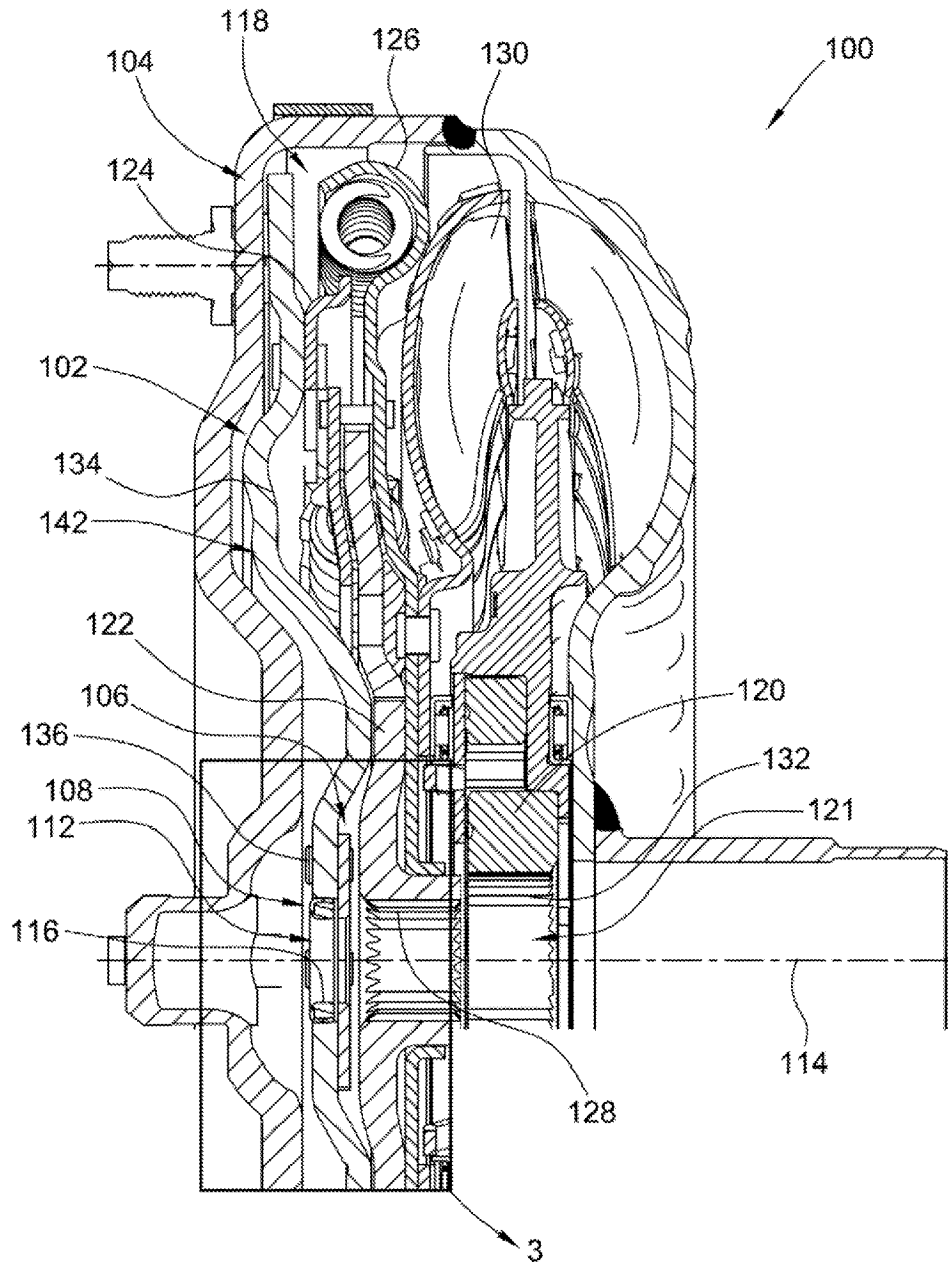

Fig. 2

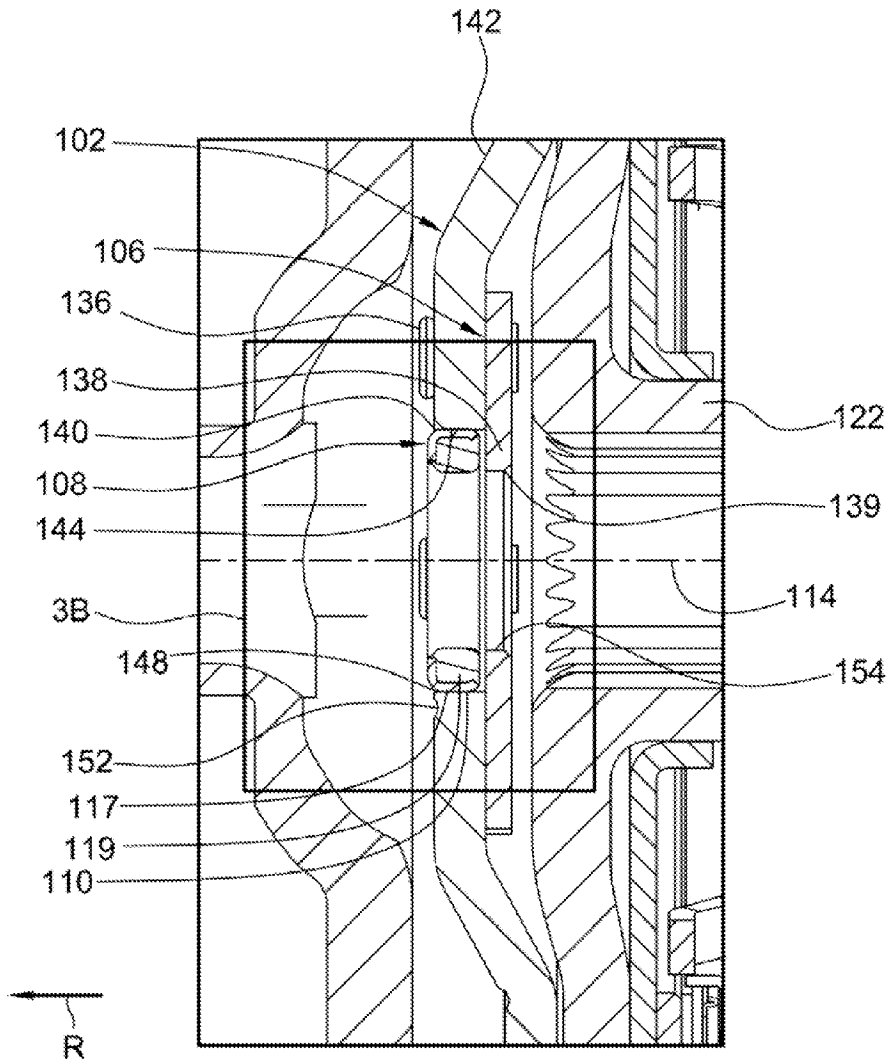

Fig. 3A

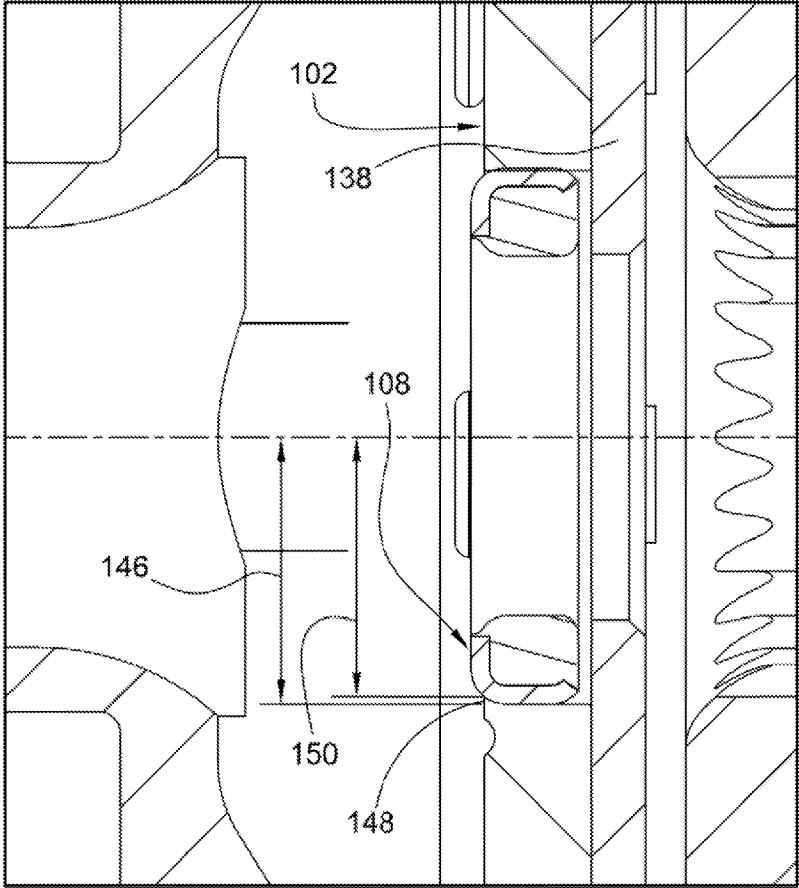

Fig. 3B

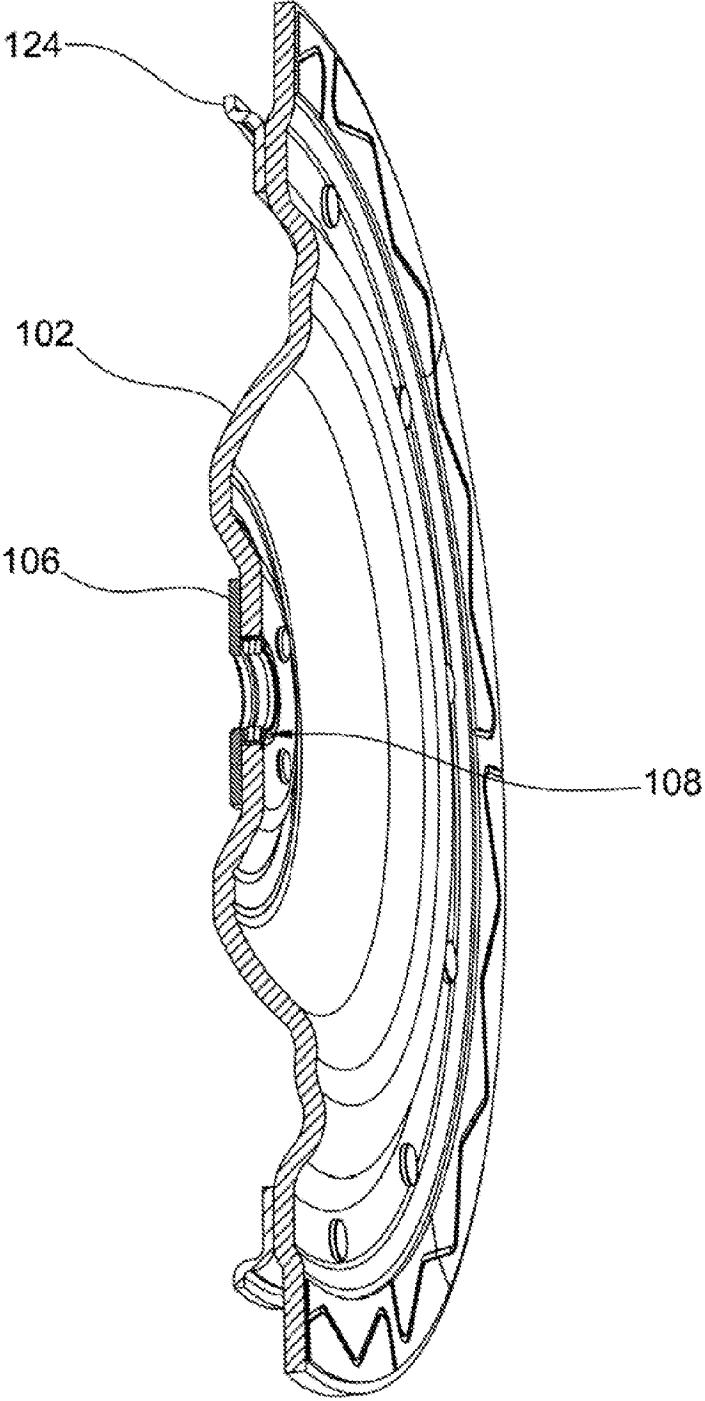

Fig. 4

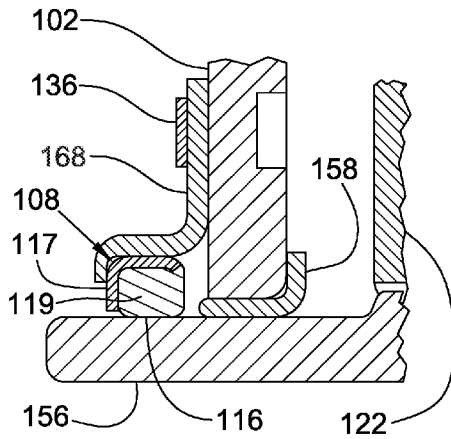

Fig. 5A

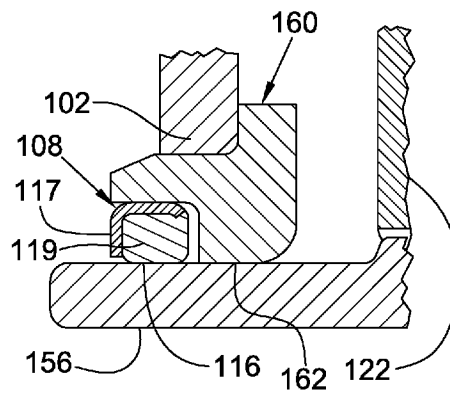

Fig. 5B

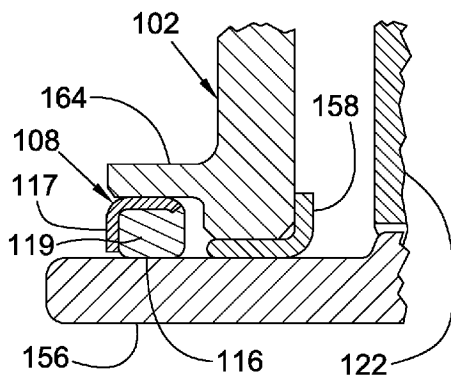

Fig. 5C

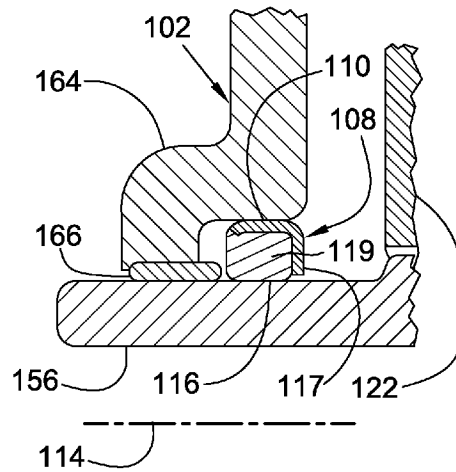

Fig. 5D

1

**PISTON SEAL WITH CENTERING WASHER**CROSS-REFERENCE TO RELATED  
APPLICATIONS

This application claims the benefit under 35 U.S.C. §119 (e) of U.S. Provisional Application No. 61/385,678 filed on Sep. 23, 2010 which application is incorporated herein by reference.

## FIELD OF THE INVENTION

The present disclosure relates to seal and ring-shaped element for sealing a plate in a torque converter with respect to an input shaft inserted in the torque converter. In particular, the present disclosure relates to a seal and washer for sealing and centering a piston plate for a lock up clutch with respect to the input shaft.

## BACKGROUND OF THE INVENTION

Known torque converter design includes using an output hub to connect a damper assembly to an input shaft inserted in the torque converter. According to this design, a piston plate for a lock up clutch in the torque converter is sealed with respect to the output hub.

## BRIEF SUMMARY OF THE INVENTION

According to aspects illustrated herein, there is provided a torque converter, including: a piston plate for a lock-up clutch, the piston plate including a circumferential surface forming an opening axially aligned with an axis of rotation for the torque converter; a ring-shaped element fixedly secured to the piston plate; and a seal in compressive engagement with the circumferential surface, axially aligned with the ring-shaped element, and including a surface facing radially inward for forming a seal with an input shaft inserted into the torque converter.

According to aspects illustrated herein, there is provided a torque converter, including: a piston plate for a lock-up clutch; a ring-shaped element fixedly secured to the piston plate; and a seal sealed with respect to the piston plate, axially fixed with respect to the piston plate by a portion of the piston plate, and including a surface facing radially inward for forming a seal with an input shaft inserted into the torque converter.

According to aspects illustrated herein, there is provided a torque converter, including a piston plate for a lock-up clutch, a ring-shaped element, and a seal. The piston plate includes a circumferential surface forming an opening axially aligned with an axis of rotation for the torque converter and an edge formed by a radially disposed surface of the piston plate and the circumferential surface of the piston plate. The edge includes a portion at a first radial distance from the axis of rotation. The ring-shaped element is fixedly secured to a radially disposed surface of the piston plate and includes a portion axially aligned with the opening. The seal is sealed with respect to the circumferential surface, axially fixed by the portion of the edge, and includes a surface facing radially inward for forming a seal with an input shaft inserted into the torque converter, and an outer circumferential surface at a second radial distance, greater than the first radial distance, from the axis of rotation.

2

These and other objects and advantages of the present invention will be readily appreciable from the following description of the invention and from the accompanying drawings and claims.

## BRIEF DESCRIPTION OF THE DRAWINGS

Various embodiments are disclosed, by way of example only, with reference to the accompanying schematic drawings in which corresponding reference symbols indicate corresponding parts, in which:

FIG. 1A is a perspective view of a cylindrical coordinate system demonstrating spatial terminology used in the present application;

FIG. 1B is a perspective view of an object in the cylindrical coordinate system of FIG. 1A demonstrating spatial terminology used in the present application;

FIG. 2 is a partial cross-sectional view of a torque converter with a piston seal and ring-shaped element;

FIG. 3A is a detail of area 3 in FIG. 2;

FIG. 3B is a detail of a portion of FIG. 3A;

FIG. 4 is a perspective cross-sectional view of the piston plate, piston seal, and ring-shaped element shown in FIG. 2; and,

FIGS. 5A through 5D are partial cross-sectional views of a torque converter with a piston seal.

## DETAILED DESCRIPTION OF THE INVENTION

At the outset, it should be appreciated that like drawing numbers on different drawing views identify identical, or functionally similar, structural elements of the invention. It is to be understood that the invention as claimed is not limited to the disclosed aspects.

Furthermore, it is understood that this invention is not limited to the particular methodology, materials and modifications described and as such may, of course, vary. It is also understood that the terminology used herein is for the purpose of describing particular aspects only, and is not intended to limit the scope of the present invention, which is limited only by the appended claims.

Unless defined otherwise, all technical and scientific terms used herein have the same meaning as commonly understood to one of ordinary skill in the art to which this invention belongs. Although any methods, devices or materials similar or equivalent to those described herein can be used in the practice or testing of the invention, the preferred methods, devices, and materials are now described.

FIG. 1A is a perspective view of cylindrical coordinate system **80** demonstrating spatial terminology used in the present application. The present invention is at least partially described within the context of a cylindrical coordinate system. System **80** has a longitudinal axis **81**, used as the reference for the directional and spatial terms that follow. The adjectives "axial," "radial," and "circumferential" are with respect to an orientation parallel to axis **81**, radius **82** (which is orthogonal to axis **81**), and circumference **83**, respectively. The adjectives "axial," "radial" and "circumferential" also are regarding orientation parallel to respective planes. To clarify the disposition of the various planes, objects **84**, **85**, and **86** are used. Surface **87** of object **84** forms an axial plane. That is, axis **81** forms a line along the surface. Surface **88** of object **85** forms a radial plane. That is, radius **82** forms a line along the surface. Surface **89** of object **86** forms a circumferential plane. That is, circumference **83** forms a line along the surface. As a further example, axial movement or disposition is parallel to axis **81**, radial movement or disposition is par-



allel to radius **82**, and circumferential movement or disposition is parallel to circumference **83**. Rotation is with respect to axis **81**.

The adverbs “axially,” “radially,” and “circumferentially” are with respect to an orientation parallel to axis **81**, radius **82**, or circumference **83**, respectively. The adverbs “axially,” “radially,” and “circumferentially” also are regarding orientation parallel to respective planes.

FIG. 1B is a perspective view of object **90** in cylindrical coordinate system **80** of FIG. 1A demonstrating spatial terminology used in the present application. Cylindrical object **90** is representative of a cylindrical object in a cylindrical coordinate system and is not intended to limit the present invention in any manner. Object **90** includes axial surface **91**, radial surface **92**, and circumferential surface **93**. Surface **91** is part of an axial plane, surface **92** is part of a radial plane, and surface **93** is a circumferential surface.

FIG. 2 is a partial cross-sectional view of torque converter **100** with a piston seal and ring-shaped element.

FIG. 3A is a detail of area **3** in FIG. 2.

FIG. 3B is a detail of a portion of FIG. 3A.

FIG. 4 is a perspective cross-sectional view of the piston plate, piston seal, and ring-shaped element shown in FIG. 2. The following should be viewed in light of FIGS. 2 through 4. Torque converter **100** includes piston plate **102** for a lock-up clutch **104**, ring-shaped element **106**, and seal **108**. The piston plate includes circumferential surface **110** forming opening **112** axially aligned with axis of rotation **114** for the torque converter. The ring-shaped element is fixedly secured to the piston plate as further described infra. The seal is in compressive engagement with the circumferential surface, is sealed with respect to the circumferential surface, is in contact with the ring-shaped element, and includes surface **116**, facing radially inward, for forming a seal with an input shaft (not shown) inserted into the torque converter. The seal is fixed with respect to the piston plate as further described infra.

In one embodiment, the seal includes cover **117** and sealing material **119** fixedly secured to the cover. Cover **117** is made of any material known in the art, for example, metal. The sealing material is any sealing material known in the art, including, but not limited to fluoroelastomer, fluorocarbon, or ethylene acrylate. The cover is pressed into opening **112** and forms a liquid-tight seal with surface **110**. Material **119** forms surface **116**.

That is, for a typical arrangement in which torque converter **100** provides drive torque to a transmission (not shown), an input shaft for the transmission is installed, or inserted, into the torque converter in opening **121**. In one embodiment, the torque converter includes damper assembly **118** and one-way clutch inner race **120**. Race **120** includes surface **132** for engaging a stator shaft (not shown). The damper assembly includes flange **122** axially disposed between cover plates **124** and **126**. The flange includes surface **128** for engaging the input shaft. Cover plate **126** is fixedly connected to turbine **130**.

In one embodiment, the ring-shaped element is a washer. In one embodiment, the ring-shaped element is fixedly secured to radially disposed surface **134** of the piston plate by any means known in the art, for example, rivets **136**. Although element **106** is shown facing the flange, it should be understood that element **106** could be installed on the opposite side of the piston plate. Portion **138** of the washer is axially aligned with opening **112**, that is, portion **138** extends radially inward from surface **110**. Portion **138** includes chamfer **139** that enables easier assembly with the input shaft. In one embodiment, the piston plate includes edge **140** formed by radially disposed surface **142** of the piston plate and surface **110** of the

piston plate. The seal includes outer circumferential surface **144** at radial distance **146** from the axis. In one embodiment, at least portion **148** of edge **140** is at radial distance **150**, less than radial distance **146**, from the axis. Portion **148** of the piston plate extends radially inward with respect to edge **140** and portion **138** of the washer extends radially inward with respect to edge **140**.

In one embodiment, portions **148** are formed by staking the piston plate at respective areas **152**. That is, force applied at areas **152** forces the material forming the piston plate at edge **140** to bulge radially inward beyond surface **110** to relieve the pressure generated by the force. The bulging material acts to restrain axial displacement of the seal in direction R.

The washer is for centering the piston plate with respect to the axis of rotation, or with respect to the input shaft. For example, assuming the outside surface of the input shaft is the frame of reference for centering, surface **154** is in contact with the outside surface of the input shaft, and surface **154** and the washer are therefore centered with respect to the input shaft due to this contact. Due to the fixed position of the washer with respect to the piston plate, the piston plate also is centered with respect to the input shaft.

FIGS. 5A through 5D are partial cross-sectional views of a torque converter with a piston seal and transmission input shaft **156**. In FIG. 5A, seal **108** is installed on washer **168** and the washer is riveted to the piston plate. Bushing **158** is installed on the piston plate. The bushing includes a lead-in radius to facilitate assembly with the transmission input shaft. In FIG. 5B, piston hub **160** includes area **162** that acts as a bushing, for example, area **162** is heat treated, and includes a lead-in radius to facilitate assembly with the transmission input shaft. Seal **108** is pressed into the hub and the hub is pressed onto the piston plate. In FIG. 5C, piston plate **102** includes neck **164**. Bushing **158** is installed on the piston plate and includes a lead-in radius to facilitate assembly with the transmission input shaft. Seal **108** is pressed onto the piston plate at the neck. In FIG. 5D, piston plate **102** includes neck **164**. Bushing **166** is installed on the piston plate at the neck. Seal **108** is pressed onto the piston plate at the neck and piston plate juncture. Centering of the piston plate is accomplished by bushings **158** or **166** or by area **162**.

Thus, it is seen that the objects of the present invention are efficiently obtained, although modifications and changes to the invention should be readily apparent to those having ordinary skill in the art, which modifications are intended to be within the spirit and scope of the invention as claimed. It also is understood that the foregoing description is illustrative of the present invention and should not be considered as limiting. Therefore, other embodiments of the present invention are possible without departing from the spirit and scope of the present invention.

What we claim is:

1. A torque converter, comprising:

a piston plate for a lock-up clutch, the piston plate including a circumferential surface forming an opening axially aligned with an axis of rotation for the torque converter; a ring-shaped element for centering the piston plate with respect to the axis of rotation fixedly secured to the piston plate; and, a seal in compressive engagement with the circumferential surface, axially aligned with the ring-shaped element, and including a surface facing radially inward for forming a seal with an input shaft inserted into the torque converter.

2. The torque converter of claim 1 wherein the ring-shaped element is fixedly secured to a radially disposed surface of the piston plate.

5

3. The torque converter of claim 1 wherein:  
the piston plate includes an edge formed by a radially  
disposed surface of the piston plate and the circumferential  
surface of the piston plate;  
the seal includes an outer circumferential surface at a first  
radial distance from the axis; and,  
at least a portion of the edge is at a second radial distance,  
less than the first radial distance, from the axis.
4. The torque converter of claim 1 wherein:  
the ring-shaped element includes a portion axially aligned  
with the opening; and,  
the seal is axially aligned with the portion of the ring-  
shaped element.
5. The torque converter of claim 1 wherein:  
the seal includes an outer circumferential surface at a first  
radial distance from the axis;  
the piston plate includes an edge formed by a radially  
disposed surface of the piston plate and the circumferential  
surface of the piston plate;  
a portion of the edge is at a second radial distance, less than  
the first radial distance, from the axis;  
the ring-shaped element includes a portion axially aligned  
with the opening; and,  
a position of the seal with respect to the piston plate is  
axially fixed by the portion of the ring-shaped element  
and is axially offset from the portion of the edge.
6. The torque converter of claim 1 wherein the ring-shaped  
element is for centering the piston plate with respect to the  
input shaft.
7. The torque converter of claim 1 further comprising a  
damper assembly with a flange axially disposed between first  
and second cover plates and having a radially inwardly facing  
surface for engaging the input shaft.
8. A torque converter, comprising:  
a piston plate for a lock-up clutch including a circumferential  
surface forming an opening axially aligned with  
an axis of rotation for the torque converter;  
a ring-shaped element fixedly secured to the piston plate  
and including a portion axially aligned with the opening;  
and,  
a seal sealed with respect to the piston plate, axially fixed  
with respect to the piston plate by a portion of the piston  
plate, in compressive engagement with the circumferential  
surface, and including a surface facing radially  
inward for forming a seal with an input shaft inserted  
into the torque converter.
9. The torque converter of claim 8 wherein:  
the circumferential surface is at a first radial distance from  
the axis of rotation for the torque converter  
the piston plate includes an edge formed by a radially  
disposed surface of the piston plate and the circumferential  
surface of the piston plate;  
the respective portion of the piston plate includes a portion  
of the edge at a second radial distance, less than the first  
radial distance, from the axis; and,

6

- a portion of the ring-shaped element is axially aligned with  
the opening.
10. A torque converter comprising:  
an axis of rotation;  
a piston plate including:  
a first circumferential surface at a first radial distance  
from the axis of rotation; and,  
a second circumferential surface at a second radial dis-  
tance from the axis of rotation greater than the first  
radial distance;  
a ring-shaped element:  
in contact with the first, circumferential surface;  
forming an opening through which the axis of rotation  
passes; and,  
arranged to contact an input shaft inserted into the torque  
converter; and,  
a seal including:  
a cover fixedly secured to the second circumferential  
surface, and  
material:  
separate from the cover;  
connected to the cover; and,  
including a surface facing radially inward for forming  
a seal with the input shaft.
11. The torque converter of claim 10 wherein the ring-  
shaped element is separately formed from the piston plate.
12. The torque converter of claim 10, wherein, the ring-  
shaped element includes:  
a first surface facing radially outward and in compressive  
engagement with the first circumferential surface; and,  
a second surface facing radially inward and arranged to  
compressively engage the input shaft.
13. The torque converter of claim 10, wherein the ring-  
shaped element is a washer, a piston hub, a bushing, or com-  
bination thereof.
14. The torque converter of claim 10, wherein the ring-  
shaped element is a hushing.
15. The torque converter of claim 10, wherein the ring-  
shaped element is arranged to radially center the piston with  
respect to the input shaft.
16. The torque converter of claim 10, wherein the piston  
plate, comprises a neck.
17. The torque converter of claim 16, where the neck con-  
nects the first circumferential surface to the second circum-  
ferential surface.
18. The torque converter of claim 10, wherein:  
the ring-shaped element includes an outer circumferential  
surface at a third radial distance from the axis;  
the piston plate includes an edge formed by a radially  
disposed surface of the piston plate and the first circum-  
ferential surface of the piston plate; and,  
a portion of the edge is at a fourth radial distance, less than  
the third radial distance, from the axis.

\* \* \* \* \*