



US008919751B2

(12) **United States Patent**  
**Kneidel**

(10) **Patent No.:** **US 8,919,751 B2**

(45) **Date of Patent:** **Dec. 30, 2014**

(54) **RIVETED DIAPHRAGM SPRING  
HYSTERESIS PACKAGE**

(56) **References Cited**

(75) Inventor: **Craig Kneidel**, Massillon, OH (US)  
(73) Assignee: **Schaeffler Technologies GmbH & Co.  
KG**, Herzogenaurach (DE)  
(\* ) Notice: Subject to any disclaimer, the term of this  
patent is extended or adjusted under 35  
U.S.C. 154(b) by 107 days.

U.S. PATENT DOCUMENTS

2,364,988	A *	12/1944	McFarland	464/68.41
2,943,661	A *	7/1960	Stern	411/134
3,266,271	A *	8/1966	Stromberg	464/64.1
4,093,054	A	6/1978	Johns	
4,406,357	A *	9/1983	Nagano et al.	192/213.31
4,537,295	A *	8/1985	Fadler et al.	192/213.12
4,585,110	A *	4/1986	Gobel et al.	192/214.1
4,690,257	A *	9/1987	Suzuki et al.	192/3.31
4,690,365	A *	9/1987	Miller et al.	248/650
4,941,860	A *	7/1990	Graton	464/68.4
5,518,099	A *	5/1996	Murphy	192/207
5,687,453	A *	11/1997	Megregian et al.	16/221
6,146,279	A *	11/2000	Lebas et al.	464/68.41
6,939,097	B2 *	9/2005	Carr et al.	411/368
2010/0210366	A1	8/2010	Droll et al.	

(21) Appl. No.: **13/541,165**

(22) Filed: **Jul. 3, 2012**

(65) **Prior Publication Data**

US 2013/0015612 A1 Jan. 17, 2013

**Related U.S. Application Data**

(60) Provisional application No. 61/506,334, filed on Jul. 11, 2011.

(51) **Int. Cl.**  
**F16F 1/20** (2006.01)  
**F16D 3/14** (2006.01)  
**F16F 15/129** (2006.01)  
**F16D 13/68** (2006.01)  
**F16F 3/02** (2006.01)

(52) **U.S. Cl.**  
CPC . **F16D 13/68** (2013.01); **F16F 3/02** (2013.01);  
**F16F 15/129** (2013.01)  
USPC ..... **267/162**; 192/214; 192/214.1; 464/68.41

(58) **Field of Classification Search**  
CPC ..... F16B 39/24; Y10S 411/96; F16F 15/129;  
F16F 15/1238; F16F 1/32  
USPC ..... 267/158, 161, 162, 164, 165, 159;  
411/544, 155, 156; 464/68.4, 68.41,  
464/68.9, 84, 100, 169, 180; 192/70.17,  
192/212-214.1

See application file for complete search history.

\* cited by examiner

*Primary Examiner* — Bradley King

*Assistant Examiner* — Stephen Bowes

(74) *Attorney, Agent, or Firm* — Simpson & Simpson, PLLC

(57) **ABSTRACT**

A hysteresis assembly, including: first, second, and third plates; at least one fastener connecting the first and third plates; and, at least one resilient element. The resilient element is: disposed between the first and second plates; disposed about the fastener; and arranged to urge the second plate into frictional contact with the third plate. A damper assembly, including: first and second cover plates arranged to receive torque; a flange axially disposed between the cover plates; at least one first resilient element engaged with the cover plates and the flange and arranged to transmit the torque to the flange; at least one fastener connecting the cover plates and passing through the flange; and at least one second resilient element. The resilient element is: disposed between the first cover plate and the flange; disposed about the fastener; and arranged to urge the flange into frictional contact with the second cover plate.

**9 Claims, 6 Drawing Sheets**

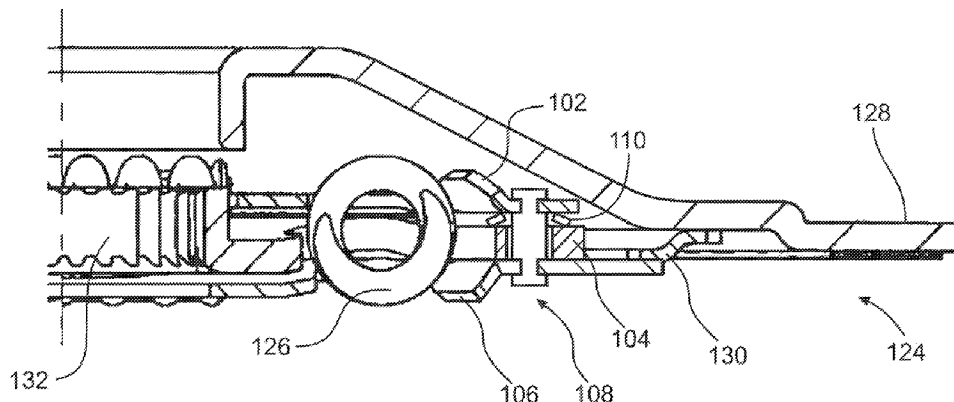

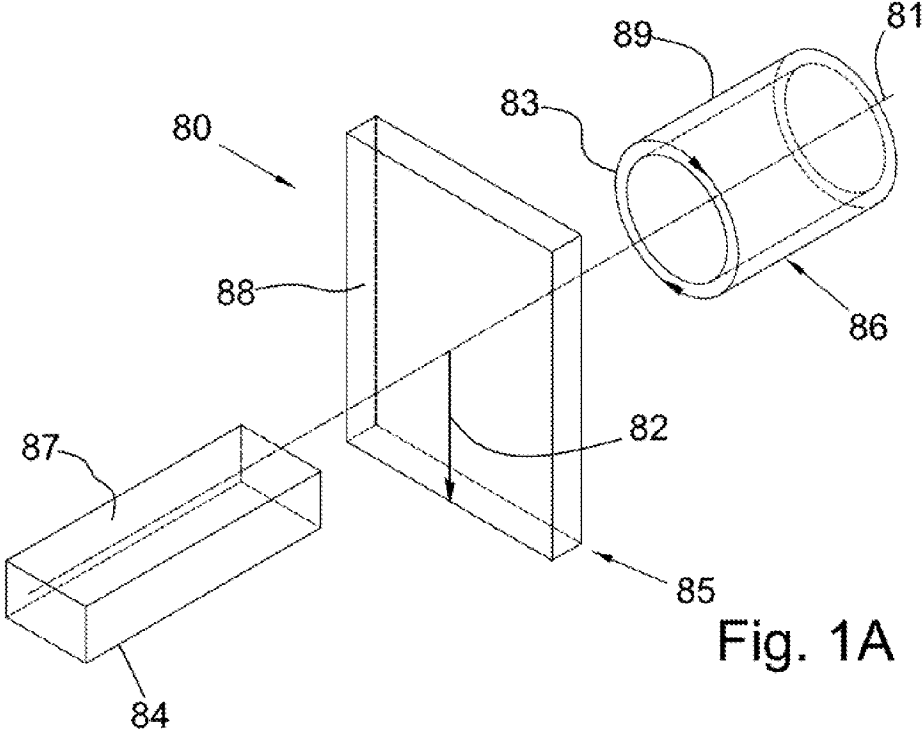

Fig. 1A

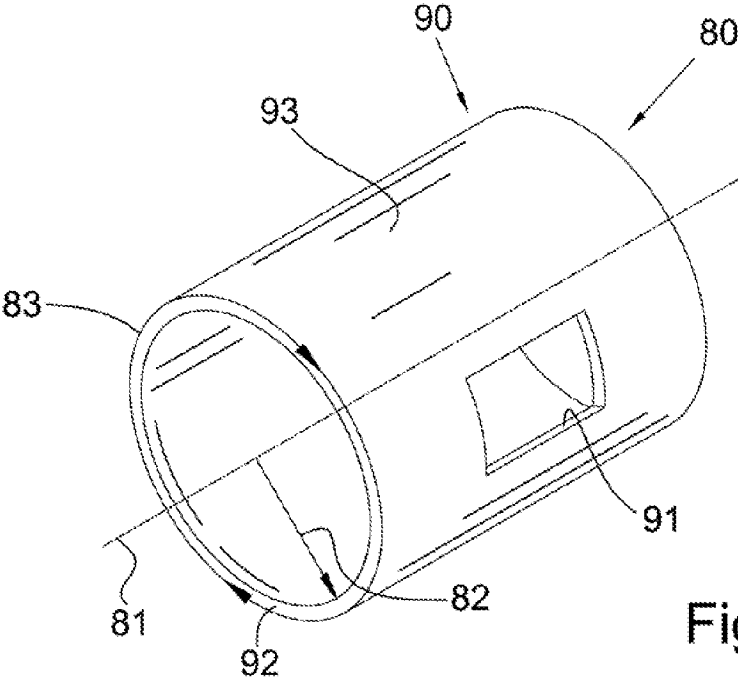

Fig. 1B

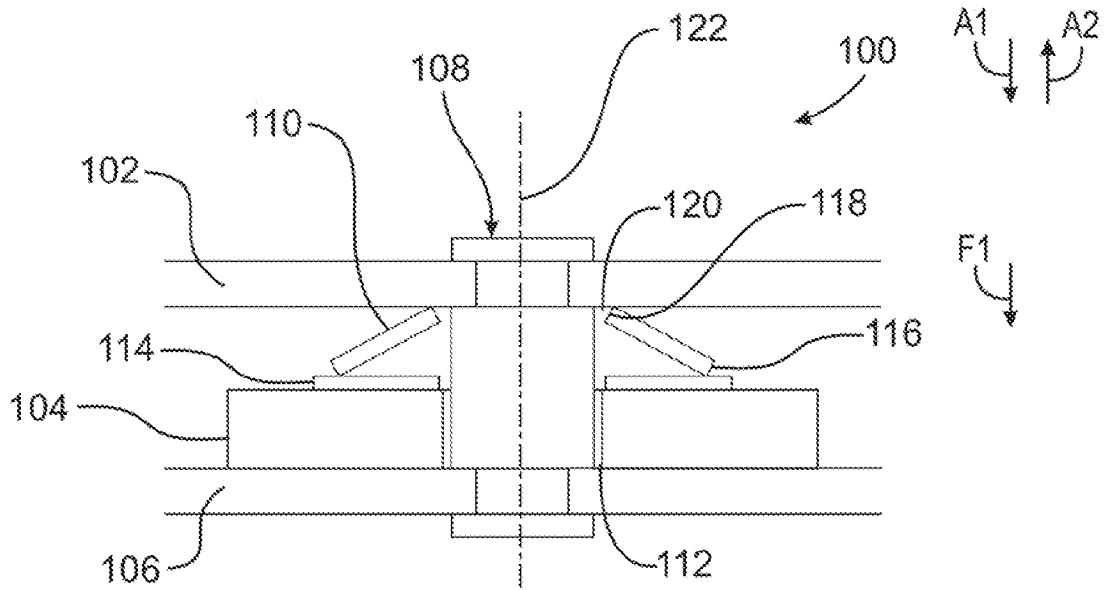

Fig. 2

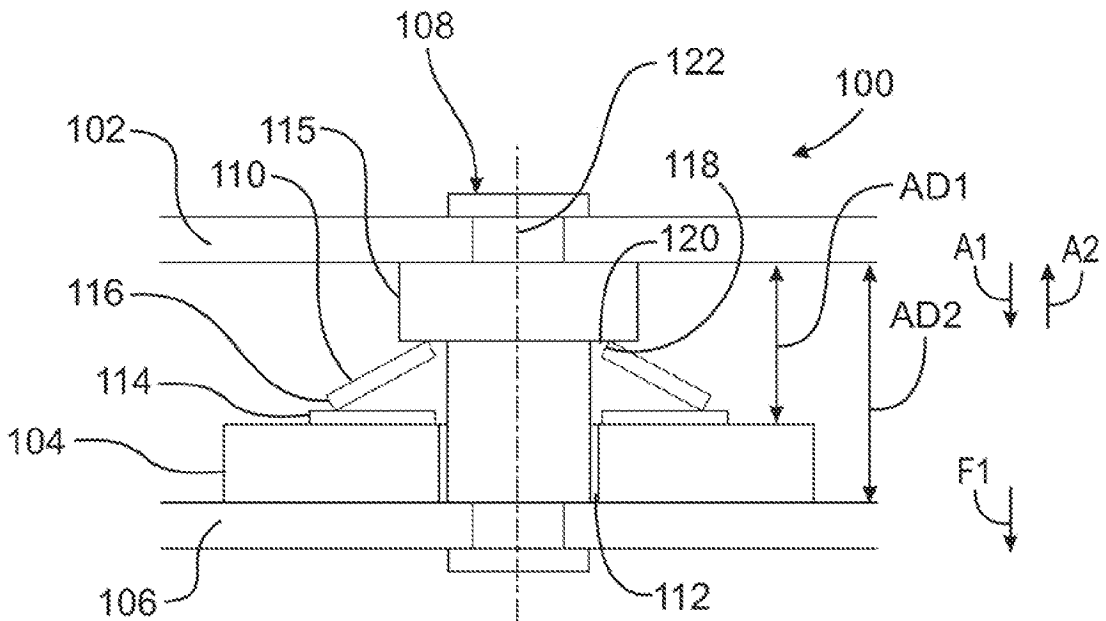

Fig. 3

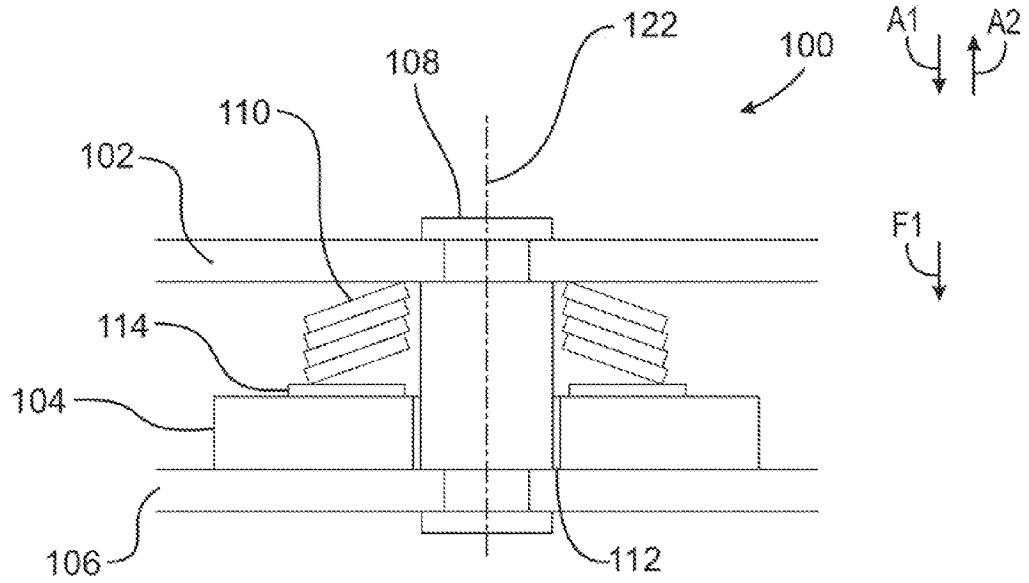

Fig. 4

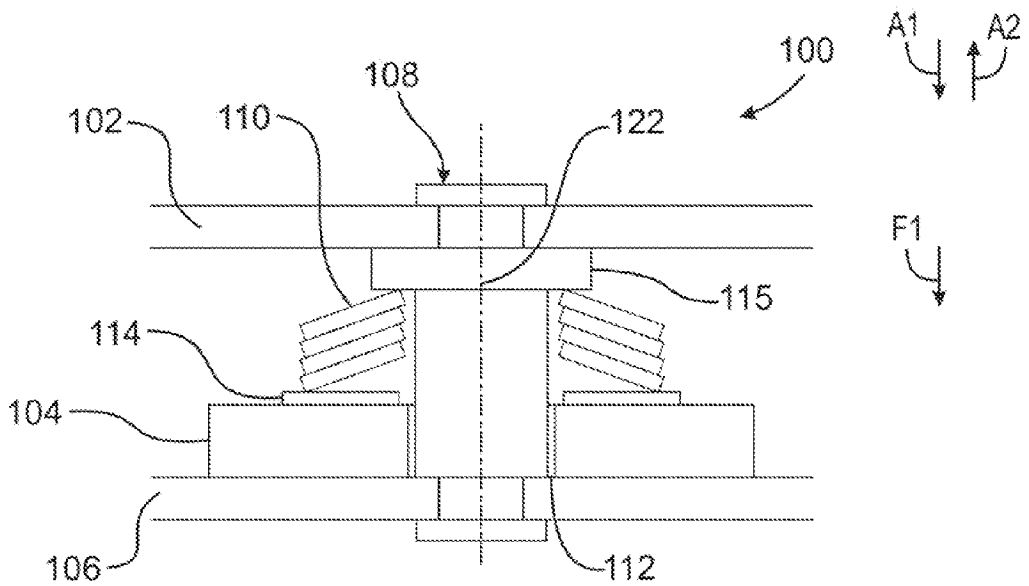

Fig. 5

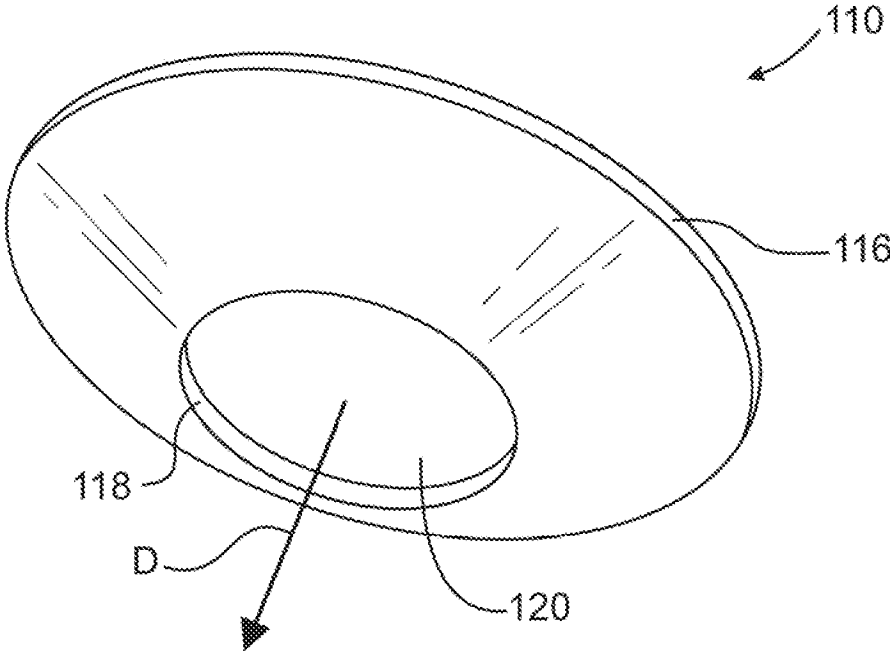

Fig. 6

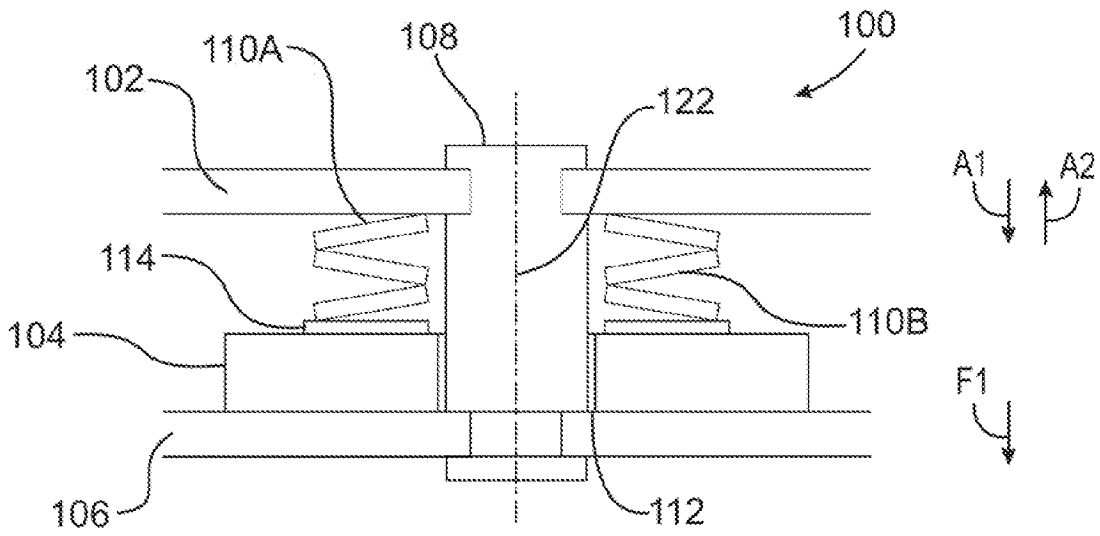

Fig. 7

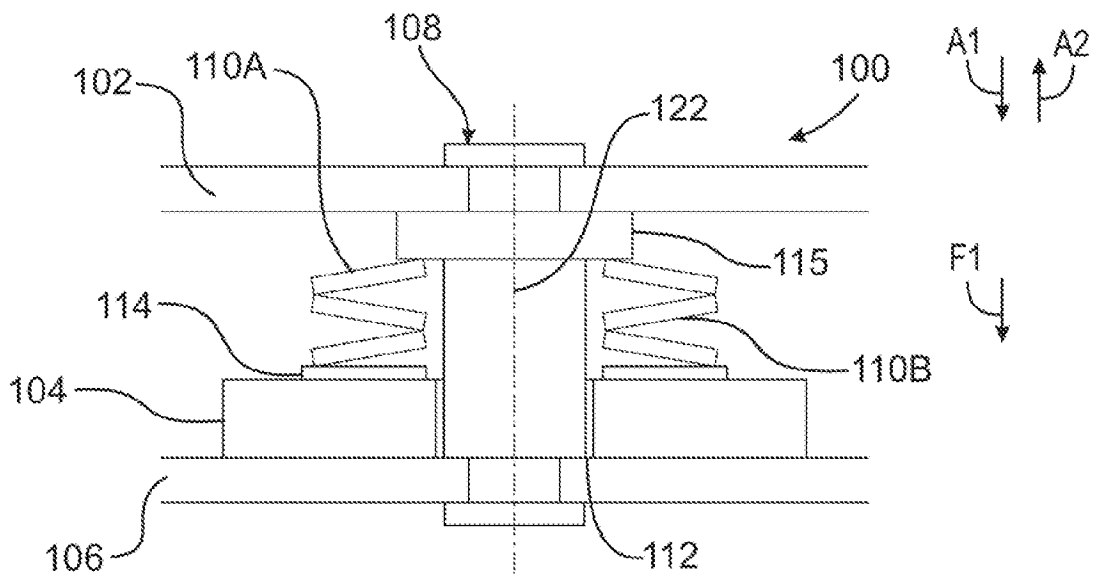

Fig. 8

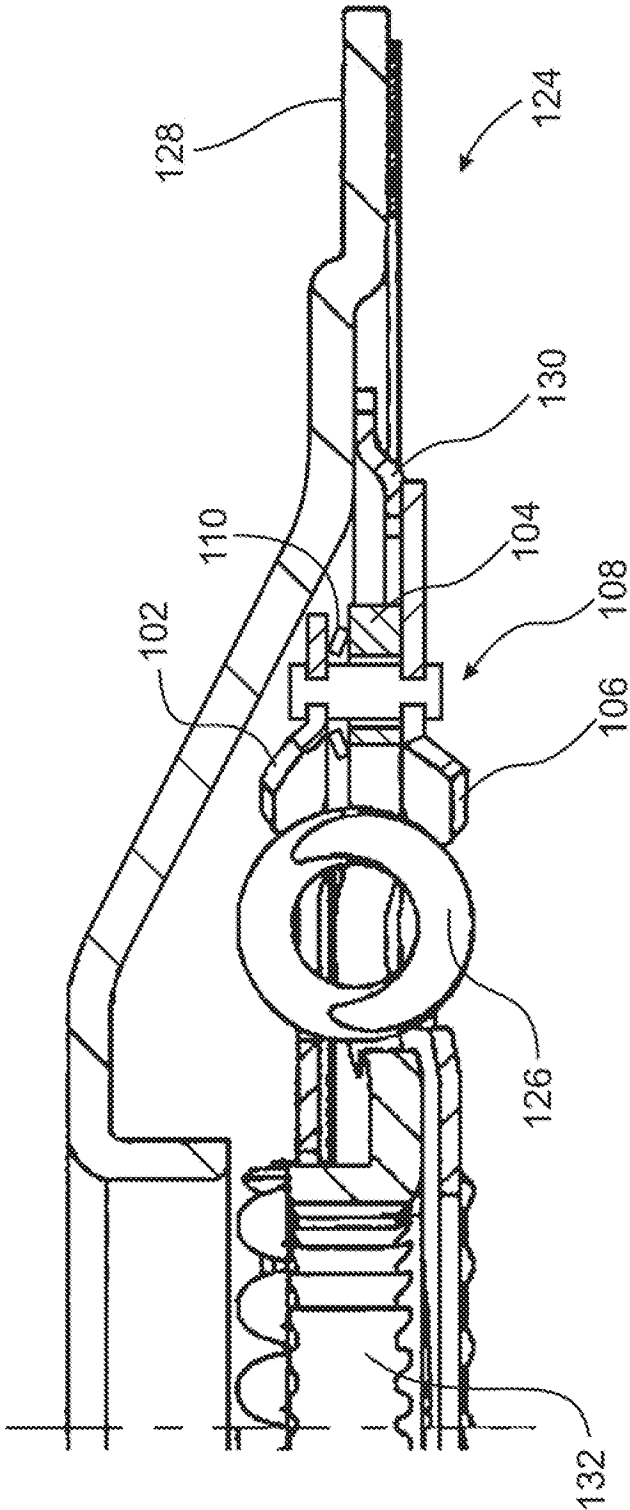

Fig. 9

1

## RIVETED DIAPHRAGM SPRING HYSTERESIS PACKAGE

### CROSS-REFERENCE TO RELATED APPLICATIONS

This application claims the benefit under 35 U.S.C. §119 (e) of U.S. Provisional Application No. 61/506,334 filed Jul. 11, 2011, which application is incorporated herein by reference.

### TECHNICAL FIELD

The present disclosure relates to a hysteresis assembly, in particular, a hysteresis assembly in a damper. One or more resilient elements are placed about fasteners connecting plates in the hysteresis or damper assembly to urge plates in the hysteresis or damper assembly into frictional contact.

### BACKGROUND

It is known to use a single diaphragm spring, fully surrounding an axis of rotation for a damper, to create hysteresis in the damper assembly. Specifically, the diaphragm spring reacts against a cover plate to urge a flange into frictional engagement with another cover plate. The use of a single washer requires a full 360 degree installation space, which limits fabrication options. Stamping a diaphragm spring large enough to use as described above generates an undesirably large amount of scrap material.

### SUMMARY

According to aspects illustrated herein, there is provided a hysteresis assembly, including: first, second, and third plates; at least one fastener connecting the first and third plates; and, at least one resilient element. The at least one resilient element is: disposed, in an axial direction, between the first and second plates; disposed about the at least one fastener; and arranged to urge the second plate into frictional contact with the third plate.

According to aspects illustrated herein, there is provided a damper assembly, including: first and second cover plates arranged to receive torque; a flange axially disposed between the first and second cover plates; at least one first resilient element engaged with the first and second cover plates and the flange and arranged to transmit the torque to the flange; at least one fastener connecting the first and second cover plates and passing through the flange; and at least one second resilient element. The at least one resilient element is: axially disposed between the first cover plate and the flange; disposed about the at least one fastener; and arranged to urge the flange into frictional contact with the second cover plate.

According to aspects illustrated herein, there is provided a damper assembly, including: first and second cover plates arranged to receive torque; a flange axially disposed between the first and second cover plates; at least one first resilient element engaged with the first and second cover plates and the flange and arranged to transmit the torque to the flange; at least one fastener fixedly connected to the first and second cover plates, passing through the flange, and at least partially rotatable with respect to the flange; and a plurality of second resilient elements. The plurality of second resilient elements: wholly axially disposed between the first cover plate and the flange; disposed about the at least one fastener; arranged to urge the flange into frictional contact with the second cover plate; and having respective outer circumferences and respec-

2

tive openings forming respective inner circumferences. The respective inner circumferences are disposed further in a first direction, with respect to respective axis passing through the respective openings, than the respective outer circumferences. For each resilient element in the plurality of second resilient elements: the first direction is from the second plate toward the first plate; or the first direction is from the first plate toward the second plate; or for one resilient element in the plurality of second resilient elements, the first direction is from the second plate toward the first plate; and for another resilient element in the plurality of second resilient elements, the first direction is from the first plate toward the second plate.

These and other objects and advantages of the present disclosure will be readily appreciable from the following description of the invention and from the accompanying drawings and claims.

### BRIEF DESCRIPTION OF THE DRAWINGS

Various embodiments are disclosed, by way of example only, with reference to the accompanying schematic drawings in which corresponding reference symbols indicate corresponding parts, in which:

FIG. 1A is a perspective view of a cylindrical coordinate system demonstrating spatial terminology used in the present application;

FIG. 1B is a perspective view of an object in the cylindrical coordinate system of FIG. 1A demonstrating spatial terminology used in the present application; and,

FIG. 2 is a cross-section of a portion of a hysteresis assembly with a wear element and a single resilient element at a fastener;

FIG. 3 is a cross-section of a portion of a hysteresis assembly with a wear element, a spacer element, and a single resilient element at a fastener;

FIG. 4 is a cross-section of a portion of a hysteresis assembly with a wear element and a plurality of resilient elements, in a parallel orientation, at a fastener;

FIG. 5 is a cross-section of a portion of a hysteresis assembly with a wear element, a spacer element, and a plurality of resilient elements, in a parallel orientation, at a fastener;

FIG. 6 is a perspective view of a resilient element;

FIG. 7 is a cross-section of a portion of a hysteresis assembly with a wear element and a plurality of resilient elements, in a series orientation, at a fastener;

FIG. 8 is a cross-section of a portion of a hysteresis assembly with a wear element, a spacer element, and a plurality of resilient elements, in a series orientation, at a fastener; and,

FIG. 9 is a partial cross-sectional view of a damper assembly incorporating a hysteresis assembly.

### DETAILED DESCRIPTION

At the outset, it should be appreciated that like drawing numbers on different drawing views identify identical, or functionally similar, structural elements of the disclosure. It is to be understood that the disclosure as claimed is not limited to the disclosed aspects.

Furthermore, it is understood that this disclosure is not limited to the particular methodology, materials and modifications described and as such may, of course, vary. It is also understood that the terminology used herein is for the purpose of describing particular aspects only, and is not intended to limit the scope of the present disclosure.

Unless defined otherwise, all technical and scientific terms used herein have the same meaning as commonly understood



3

to one of ordinary skill in the art to which this disclosure belongs. It should be understood that any methods, devices or materials similar or equivalent to those described herein can be used in the practice or testing of the disclosure.

FIG. 1A is a perspective view of cylindrical coordinate system **80** demonstrating spatial terminology used in the present application. The present invention is at least partially described within the context of a cylindrical coordinate system. System **80** has a longitudinal axis **81**, used as the reference for the directional and spatial terms that follow. The adjectives “axial,” “radial,” and “circumferential” are with respect to an orientation parallel to axis **81**, radius **82** (which is orthogonal to axis **81**), and circumference **83**, respectively. The adjectives “axial,” “radial” and “circumferential” also are regarding orientation parallel to respective planes. To clarify the disposition of the various planes, objects **84**, **85**, and **86** are used. Surface **87** of object **84** forms an axial plane. That is, axis **81** forms a line along the surface. Surface **88** of object **85** forms a radial plane. That is, radius **82** forms a line along the surface. Surface **89** of object **86** forms a circumferential plane. That is, circumference **83** forms a line along the surface. As a further example, axial movement or disposition is parallel to axis **81**, radial movement or disposition is parallel to radius **82**, and circumferential movement or disposition is parallel to circumference **83**. Rotation is with respect to axis **81**.

The adverbs “axially,” “radially,” and “circumferentially” are with respect to an orientation parallel to axis **81**, radius **82**, or circumference **83**, respectively. The adverbs “axially,” “radially,” and “circumferentially” also are regarding orientation parallel to respective planes.

FIG. 1B is a perspective view of object **90** in cylindrical coordinate system **80** of FIG. 1A demonstrating spatial terminology used in the present application. Cylindrical object **90** is representative of a cylindrical object in a cylindrical coordinate system and is not intended to limit the present invention in any manner. Object **90** includes axial surface **91**, radial surface **92**, and circumferential surface **93**. Surface **91** is part of an axial plane, surface **92** is part of a radial plane, and surface **93** is a circumferential surface.

FIG. 2 is a cross-section of a portion of hysteresis assembly **100** with a wear element and a single resilient element at a fastener. Hysteresis assembly **100** includes plates **102**, **104**, and **106**, at least one fastener **108**, and at least one resilient element **110**. Fastener **108** connects plates **102** and **106**. Resilient element **110**: is wholly disposed in an axial direction between plates **102** and **104**; disposed about fastener **108**; and urges plate **104** into frictional contact with plate **106**, for example, by urging plate **104** in direction **A1**. Fastener **108** is fixed with respect to plates **102** and **106** and passes through plate **104**, for example, passes through opening **112** in plate **104**. Plate **104** is at least partially rotatable with respect to fastener **108**, for example, opening **112** is large enough to enable the fastener to circumferentially displace within the opening. In one embodiment, resilient element **110** is in contact with plates **102** and **104**. In one embodiment, assembly **100** includes wear element **114** disposed between resilient element **110** and plate **104** and in contact with resilient element **110** and plate **104**. As further described below, wear element **114** protects plate **104** from damage due to the displacement of resilient element **110**. In an example embodiment, resilient element **110** is a diaphragm spring or Belleville washer. In an example embodiment, fastener **108** is a rivet.

FIG. 3 is a cross-section of a portion of hysteresis assembly **100** with a wear element, a spacer element, and a single resilient element at a fastener. In one embodiment, assembly **100** includes at least one spacer element **115** between plate

4

**102** and resilient element **110** and in contact with plate **102** and resilient element **110**. In one embodiment, the spacer element is formed of a same piece of material as the fastener, that is, the spacer element is integral to the fastener. In one embodiment, the spacer element is separate from the fastener, for example, the spacer element is a washer disposed about the fastener. Spacer element **115** can be used to control or modify axial distance **AD1** between plates **102** and **104** or to control or modify axial distance **AD2** between plates **102** and **106**, for example, to increase respective values for **AD1** and **AD2**.

FIG. 4 is a cross-section of a portion of hysteresis assembly **100** with a wear element and a plurality of resilient elements, in a parallel orientation, at a fastener.

FIG. 5 is a cross-section of a portion of a hysteresis assembly with a wear element, a spacer element, and a plurality of resilient elements, in a parallel orientation, at a fastener.

FIG. 6 is a perspective view of a resilient element. The following should be viewed in light of FIGS. 2 through 6. In one embodiment assembly **100** includes a plurality of resilient elements **110** having respective outer circumferences **116** and respective openings **118** forming respective inner circumferences **120**. As shown in FIG. 6, an inner circumference **120** is disposed further in direction **D**, with respect to axis **122** passing through opening **118**, than an outer circumference **116**. In one embodiment, as shown in FIGS. 4 and 5, for each resilient element **110** in the plurality of resilient elements, direction **D** is in the same direction, for example, parallel to direction **A1** or **A2**. In FIGS. 4 and 5, the same direction is **A2**, that is, from plate **104** toward plate **102**. That is, each resilient element is in a same configuration in which the inner circumference is closer to one of plates **102** or **104** than the outer circumference. This is a parallel configuration in which the resistance of resilient elements **110** to compression is additive, as further described below.

Stated otherwise, as shown in FIGS. 4 and 5, each resilient element **110** in the plurality of resilient elements **110** exerts a respective force resisting compression of the respective inner and outer circumference toward each other. This force can be expressed in terms of the spring constant for the resilient element, which has the general form  $k=y$  force/distance of compression, for example,  $k=y$  Newtons/meter. In the parallel configuration of FIGS. 4 and 5, assuming  $k$  is the same for each element and plate **102** is compressed a distance  $d$  toward plate **104** (assuming plate **102** starts in contact with elements **110**, but is not applying an axial force to the elements) the net force **F1** exerted by the three elements **110** on plate **104** can be expressed as  $F1=(k \times d)+(k \times d)+(k \times d)$ . Thus, if  $y=100$  and  $d=0.001$  m (one millimeter), the net force **F1** exerted by the three elements **110** on plate **104** is  $F1=(100 \text{ Newtons/meter} \times 0.001 \text{ meters})+(100 \text{ Newtons/meter} \times 0.001 \text{ meters})+(100 \text{ Newtons/meter} \times 0.001 \text{ meters})=0.3 \text{ Newtons}$ . Elements **110** react against plate **102** to generate Force **F1** in direction **A1**, urging plate **104** into frictional contact with plate **106**.

FIG. 7 is a cross-section of a portion of hysteresis assembly **100** with a wear element and a plurality of resilient elements, in a series orientation, at a fastener.

FIG. 8 is a cross-section of a portion of hysteresis assembly **100** with a wear element, a spacer element, and a plurality of resilient elements, in a series orientation, at a fastener. The following should be viewed in light of FIGS. 2, 3, and 6 through 8. For at least one resilient element **110** in the plurality of resilient elements, for example, element **110A**, direction **D** is in one direction and for at least one other resilient element **110**, for example, **110B**, direction **D** is in another, opposite direction. For example, for **110A**, **D** is parallel to direction **A2**, from plate **104** toward plate **102** and for **110B**, **D** is parallel to direction **A1** from plate **102** toward plate **104**.

5

It should be understood that the directions noted above could be reversed. This is a series configuration in which the resistance of resilient elements **110A** and **110B** to compression in direction **A1** is not additive as described below. In FIG. 5, resilient elements **110A** and **110B** alternate.

As described above, force generated by compression of an element **110** can be expressed in terms of the spring constant for the resilient element, which has the general form  $k=y$  force/distance of compression, for example,  $k=y$  Newtons/meter. In the series configuration of FIGS. 4 and 5, assuming  $k$  is the same for each element and plate **102** is compressed a distance  $d$  toward plate **104** (assuming plate **102** starts in contact with elements **110**, but is not applying an axial force to the elements) the net force  $F1$  exerted by the three elements **110** on plate **104** can be expressed as  $1/F1=1/(k \times d)+1/(k \times d)+1/(k \times d)$ . Thus, if  $y=100$  and  $d=0.001$  m (one millimeter), the net force  $F1$  exerted by the three elements **110** on plate **104** is  $1/F1=1/(100 \text{ Newtons/meter} \times 0.001 \text{ meters})+1/(100 \text{ Newtons/meter} \times 0.001 \text{ meters})+1/(100 \text{ Newtons/meter} \times 0.001 \text{ meters})=30 \text{ Newton}^{-1}$ , so  $F1=0.033$  Newtons. Elements **110** react against plate **102** to generate Force  $F1$  in direction **A1**, urging plate **104** into frictional contact with plate **106**.

It should be understood that a combination of series and parallel configurations is possible. For example, for three elements **110**, two adjacent elements **110** could be in a parallel configuration and the remaining element **110** could be in a series configuration. The respective calculations for parallel and series forces would be applied as applicable. For example, if two adjacent elements **110** are stacked together in a parallel configuration, for example, as shown for the top two elements **110** in FIGS. 4 and 5 and a third element **110** is configured as shown for element **110B** in FIGS. 7 and 8,  $F1$  would be calculated as follows (assuming the same values for  $y$  and  $k$  as noted above):  $1/F1=(1/[(k \times d)+(k \times d)])+1/(k \times d)=(1/[0.1 \text{ Newton}+0.1 \text{ Newton}])+(1/0.1 \text{ Newton})=15 \text{ Newton}^{-1}$ , so  $F1=0.067$  Newton. Thus, for a same number of elements **110**,  $F1$  for the combined configuration falls somewhere between  $F1$  for the series and parallel configurations.

FIG. 9 is a partial cross-sectional view of a damper assembly incorporating hysteresis assembly **100**. The configuration of assembly **100** is similar to that shown in FIG. 2, that is, there is no spacer element **115** used. In one embodiment, assembly **100** includes damper assembly **124**. Plates **102** and **106** are cover plates for the damper assembly and plate **104** is a flange for the damper assembly. The damper assembly also includes at least one spring **126**, for example, a coil spring. Plates **102** and **106** are arranged to receive torque, for example, from cover **128** and drive plate **130**. The cover plates transmit the torque to spring **126**, which in turn transmits the torque to the flange. The flange transmits the torque to output hub **132**. It should be understood that any configuration of assembly **110**, including, but not limited to, the respective configurations shown in FIGS. 3-5, 7, and 8 can be used with a damper assembly.

Advantageously, unlike the prior art arrangements noted above, assemblies **100** and **124** do not require a full 360 degree access in order to install the means for creating hysteresis in the assemblies, that is to install elements **110**. Specifically, access is only required in the limited area around fasteners **108**. Further, much less scrap material is generated by the stamping of the relatively small elements **110**, in comparison with the stamping of a large diaphragm spring as described above. In addition, assemblies **100** and **124** are modular, advantageously increasing production flexibility. For example, a typical assembly **100** or **124** includes a plurality of fasteners **108**. Elements **110** can be installed at some

6

or all of the fastener locations as desired. Further, different numbers and configurations of elements **110** can be installed at the fastener locations. For example, as noted above, elements **110** can be configured in series or parallel configurations or in combinations of series and parallel configurations. Stacking elements **110** in series can stretch out a load curve for the stacked elements to accommodate a higher range of spacing tolerances between plates **104** and **106**. Stacking elements **110** in parallel can create a much higher spring load to accommodate high-hysteresis applications.

Although hysteresis assembly **100** and damper assembly **124** have been shown with respective configurations of components, it should be understood that assemblies **100** and **124** are not limited to the respective configurations of components shown and that other respective configurations of components are possible.

It will be appreciated that various of the above-disclosed and other features and functions, or alternatives thereof, may be desirably combined into many other different systems or applications. Various presently unforeseen or unanticipated alternatives, modifications, variations, or improvements therein may be subsequently made by those skilled in the art which are also intended to be encompassed by the following claims.

What I claim is:

1. A damper assembly, comprising:

first and second cover plates arranged to receive torque; a flange axially disposed between the first and second cover plates; at least one first resilient element engaged with the first and second cover plates and the flange and arranged to transmit the torque to the flange; at least one fastener, each fastener in the at least one fastener: including a respective axis; and, connecting the first and second cover plates so that the first and second cover plates are fixed with respect to each other in first and second opposite axial directions parallel to the respective axis; and, passing through the flange; and, at least one second resilient element, each second resilient element included in the at least one second resilient element: axially disposed between the first cover plate and the flange; concentrically disposed about a single respective fastener included in the at least one fastener; and, arranged to urge the flange into frictional contact with the second cover plate.

2. The damper assembly of claim 1, wherein:

the at least one fastener is fixed with respect to the first and second cover plates; and, the flange is at least partially rotatable with respect to the at least one fastener.

3. The damper assembly of claim 1, further comprising a wear element, separate from the at least one resilient element and the flange, disposed between the at least one resilient element and the flange, and in contact with the at least one resilient element and the flange.

4. The hysteresis assembly of claim 1, further comprising at least one spacer element between the first cover plate and the at least one second resilient element and in contact with the at least one second resilient element.

5. The hysteresis assembly of claim 4 wherein: the at least one spacer element is formed of a same piece of material as the at least one fastener; or,

7

the at least one spacer element is separate from the at least one fastener.

6. The hysteresis assembly of claim 1, wherein:

the at least one resilient element includes a plurality of resilient elements having respective outer circumferences and respective openings forming respective inner circumferences; and,

the respective inner circumferences are disposed further in a first direction than the respective outer circumferences; and,

wherein:

for each resilient element in the plurality of resilient elements, the first direction is the first axial direction; or,

for each resilient element in the plurality of resilient elements, the first direction is the second axial direction.

7. The hysteresis assembly of claim 1, wherein:

the at least one second resilient element includes a plurality of second resilient elements:

located in series with respect to the first and second axial directions; and,

having respective outer circumferences and respective openings forming respective inner circumferences;

each second resilient element in the plurality of second resilient elements exerts a respective force proportional to an amount by which the respective inner and outer circumferences are compressed toward each other; and,

the plurality of second resilient elements is arranged to urge the second plate into frictional contact with the third plate with a force less than the respective force for a single second resilient element in the plurality of second resilient elements.

8. The damper assembly of claim 1, wherein:

the at least one fastener includes a plurality of fasteners; the at least one second resilient element includes a plurality of second resilient elements; and,

each second resilient element in the plurality of second resilient elements is concentrically disposed about only one single respective fastener included in the plurality of fasteners.

8

9. A damper assembly, comprising:

first and second cover plates arranged to receive torque; a flange axially disposed between the first and second cover plates;

at least one first resilient element engaged with the first and second cover plates and the flange and arranged to transmit the torque to the flange;

a plurality of fasteners, each fastener included in the plurality of fasteners:

including a respective axis;

fixedly connected to the first and second cover plates;

fixing the first and second plates with respect to each other in first and second opposite axial directions parallel to the respective axis;

passing through the flange, and at least partially rotatable with respect to the flange; and,

a plurality of second resilient elements, each second resilient element:

wholly axially disposed between the first cover plate and the flange;

disposed about a single respective fastener included in the plurality of fasteners;

arranged to urge the flange into frictional contact with the second cover plate; and,

having a respective outer circumference and a respective opening forming a respective inner circumference, the respective inner circumference disposed further in a first direction than the respective outer circumference:

wherein for said each second resilient element in the plurality of second resilient elements:

the first direction is the first axial direction; or,

the first direction is the second axial direction; or,

wherein:

for one second resilient element in the plurality of second resilient elements, the first direction is the first axial direction; and,

for another second resilient element in the plurality of second resilient elements, the first direction is the second axial direction.

\* \* \* \* \*