



US009777763B2

(12) **United States Patent
Mitchell**

(10) **Patent No.:** **US 9,777,763 B2**

(45) **Date of Patent:** **Oct. 3, 2017**

(54) **HOOK WITH MAGNETIC CLOSURE**

2001/0035; A44C 5/2038; A44D 2203/00;
H01F 7/0263; Y10T 24/45435; Y10T
24/4533; Y10T 24/32

(71) Applicant: **Lucy A. Mitchell**, Melksham Wiltshire
(GB)

See application file for complete search history.

(72) Inventor: **Lucy A. Mitchell**, Melksham Wiltshire
(GB)

(56) **References Cited**

U.S. PATENT DOCUMENTS

(*) Notice: Subject to any disclaimer, the term of this
patent is extended or adjusted under 35
U.S.C. 154(b) by 131 days.

1,545,377 A * 7/1925 Westmoreland B66C 1/36
24/599.1
1,985,596 A * 12/1934 Burnham F16B 45/02
24/599.5

(21) Appl. No.: **14/708,541**

(Continued)

(22) Filed: **May 11, 2015**

FOREIGN PATENT DOCUMENTS

(65) **Prior Publication Data**

JP 05286296 11/1993
JP 09184509 7/1997

US 2015/0322996 A1 Nov. 12, 2015

Primary Examiner — Robert J Sandy

Assistant Examiner — Louis Mercado

Related U.S. Application Data

(74) *Attorney, Agent, or Firm* — Simpson & Simpson,
PLLC

(63) Continuation-in-part of application No. 13/947,588,
filed on Jul. 22, 2013, now Pat. No. 9,032,594, which
(Continued)

(57) **ABSTRACT**

(51) **Int. Cl.**

F16B 45/02 (2006.01)
F16B 45/04 (2006.01)
F16B 1/00 (2006.01)
A44C 5/20 (2006.01)
H01F 7/02 (2006.01)

A hook formed into a body formed into a hook shape and
having a neck and fabricated from nonferromagnetic mate-
rial with the body having a first end and a second end. The
neck is proximate the first end. One side of the neck includes
a center ridge with a flat top surface with either a magnet or
ferromagnetic material embedded in the center ridge. The
hook also includes a closure having a first closure end and
a second closure end and a channel with a floor flanked by
two lateral sides. A second magnet or a ferromagnetic
material is embedded into the floor opposed to the first
magnet or ferromagnetic material. The closure being pivot-
ally and/or pivotally and slidably attached to the hook body
by at least one pin. The magnet(s) and/or ferromagnetic
material hold the closure in a closed position enclosing a
defined space.

(52) **U.S. Cl.**

CPC **F16B 45/02** (2013.01); **A44C 5/2038**
(2013.01); **F16B 1/00** (2013.01); **F16B 45/04**
(2013.01); **H01F 7/0263** (2013.01); **A44D**
2203/00 (2013.01); **F16B 2001/0035**
(2013.01); **Y10T 24/32** (2015.01); **Y10T**
24/4533 (2015.01); **Y10T 24/45435** (2015.01)

(58) **Field of Classification Search**

CPC .. **F16B 45/02**; **F16B 1/00**; **F16B 45/04**; **F16B**

16 Claims, 29 Drawing Sheets

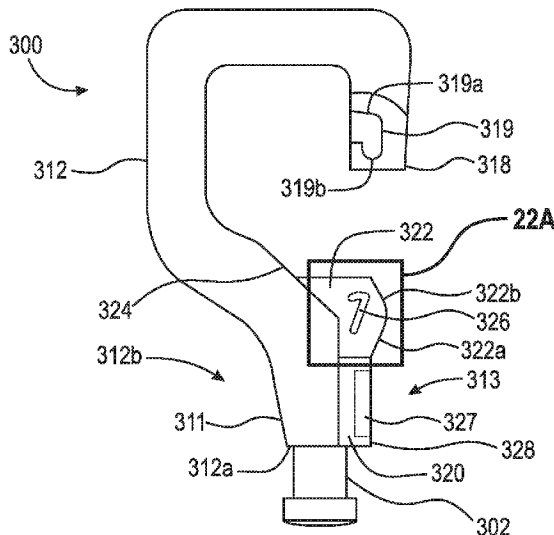

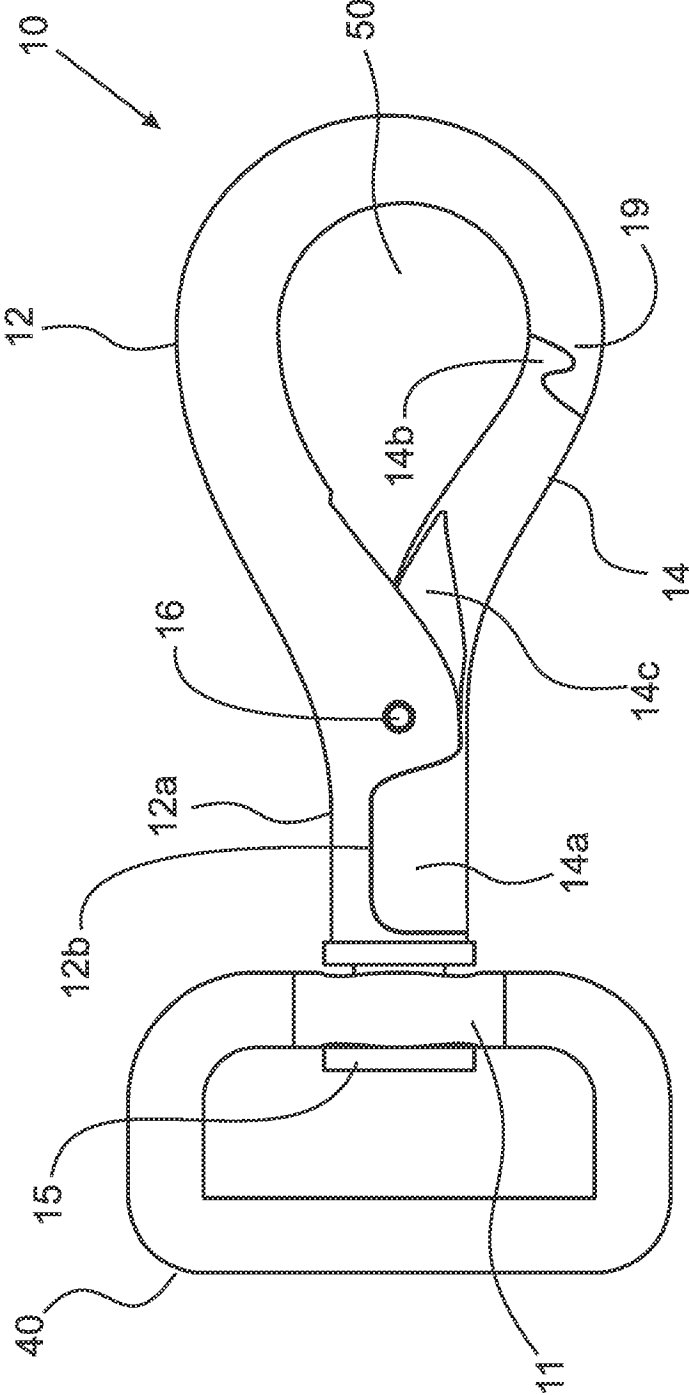

Fig. 1

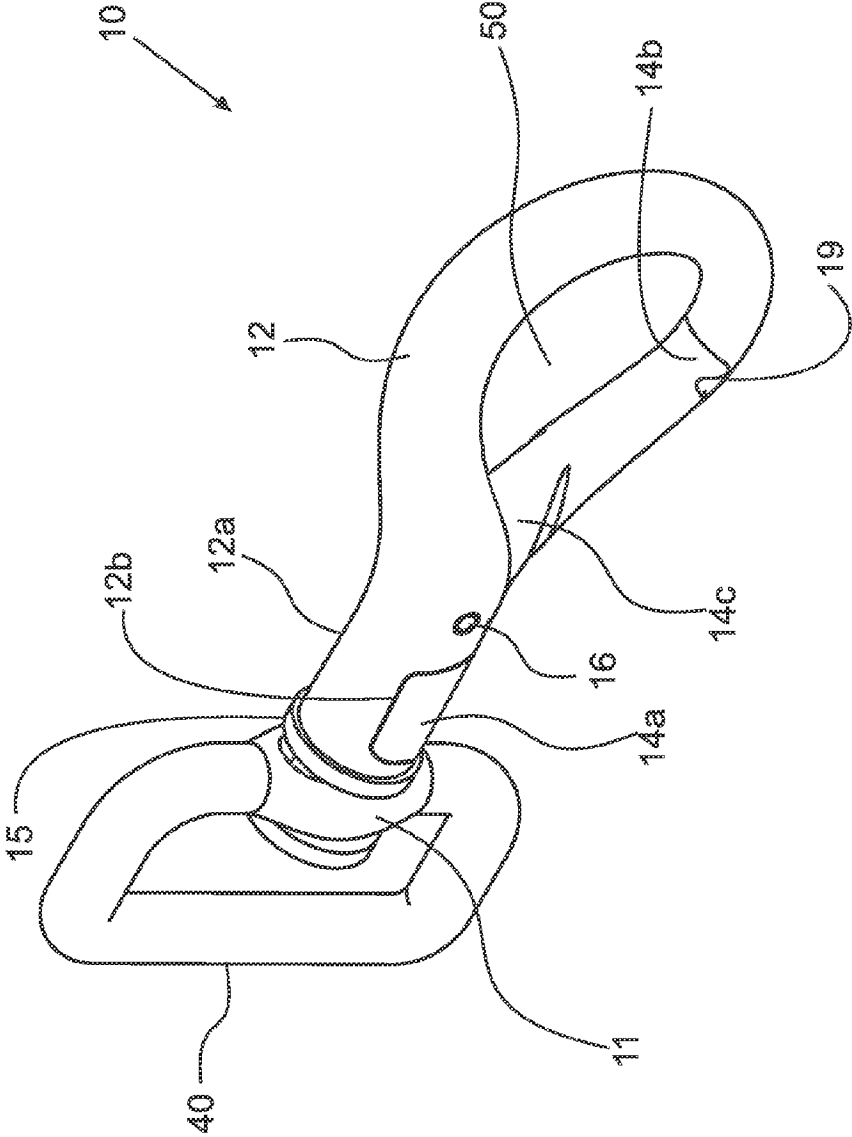
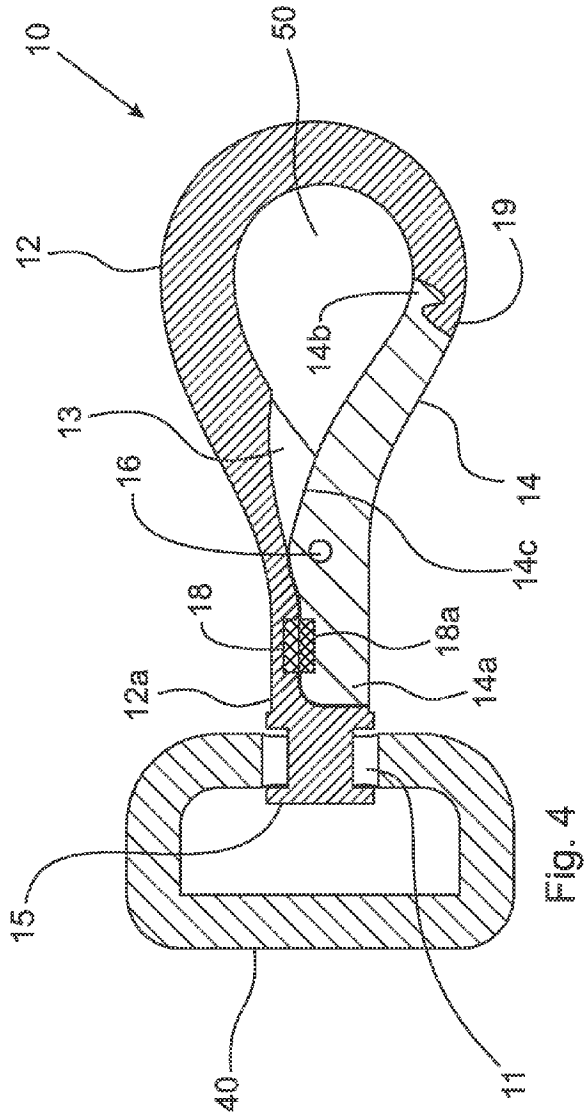
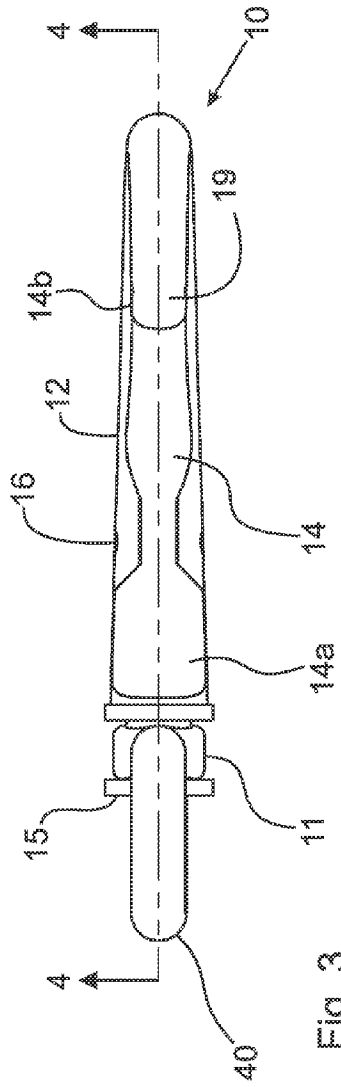
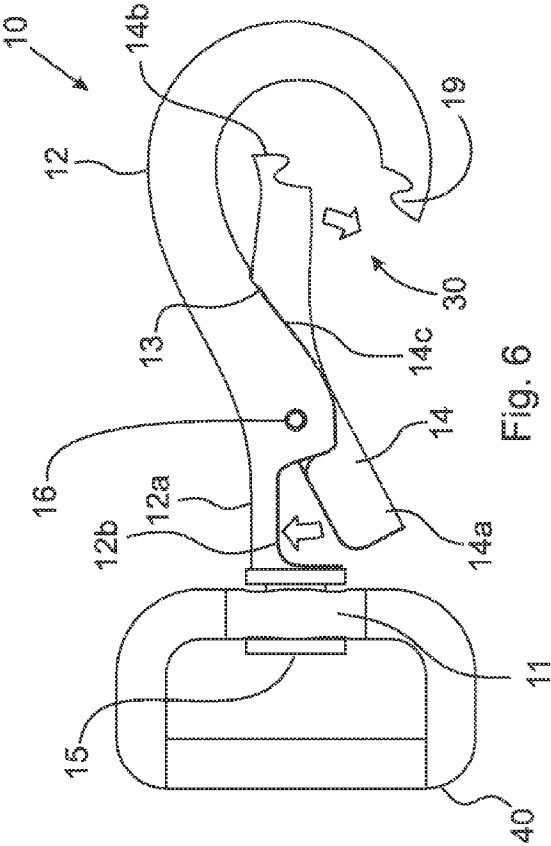
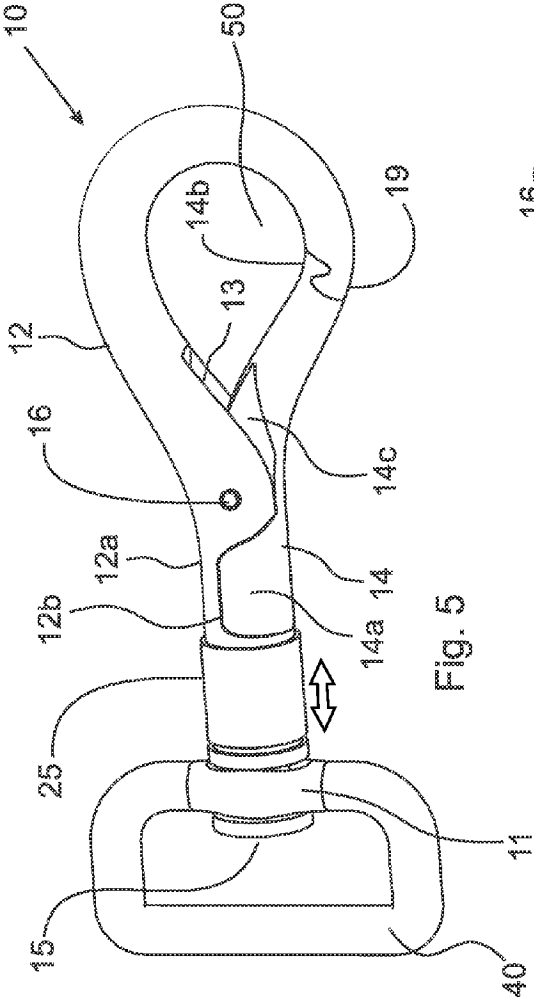

Fig. 2





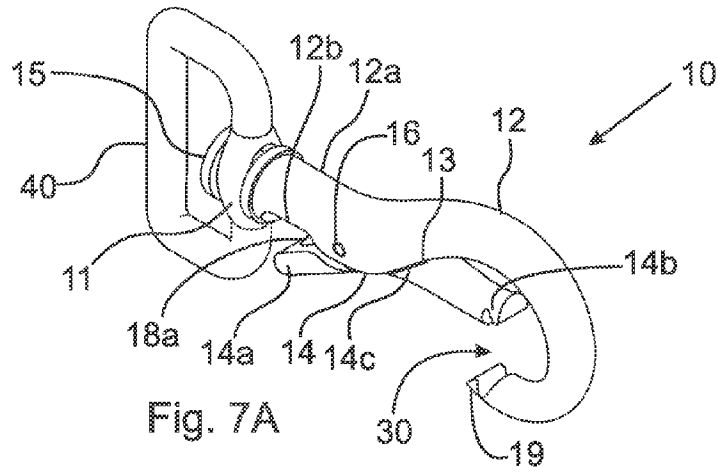

Fig. 7A

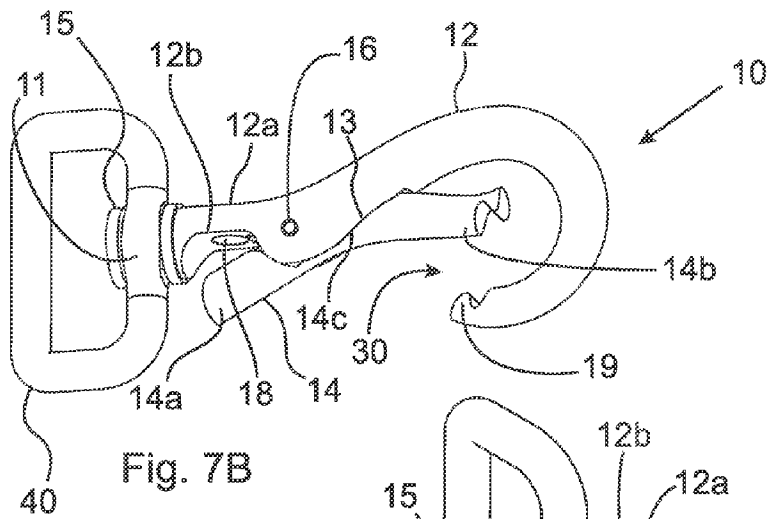

Fig. 7B

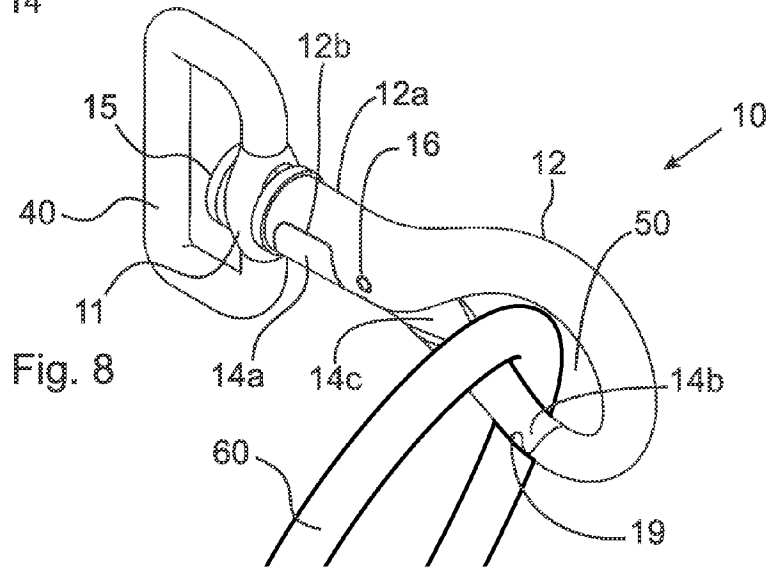

Fig. 8

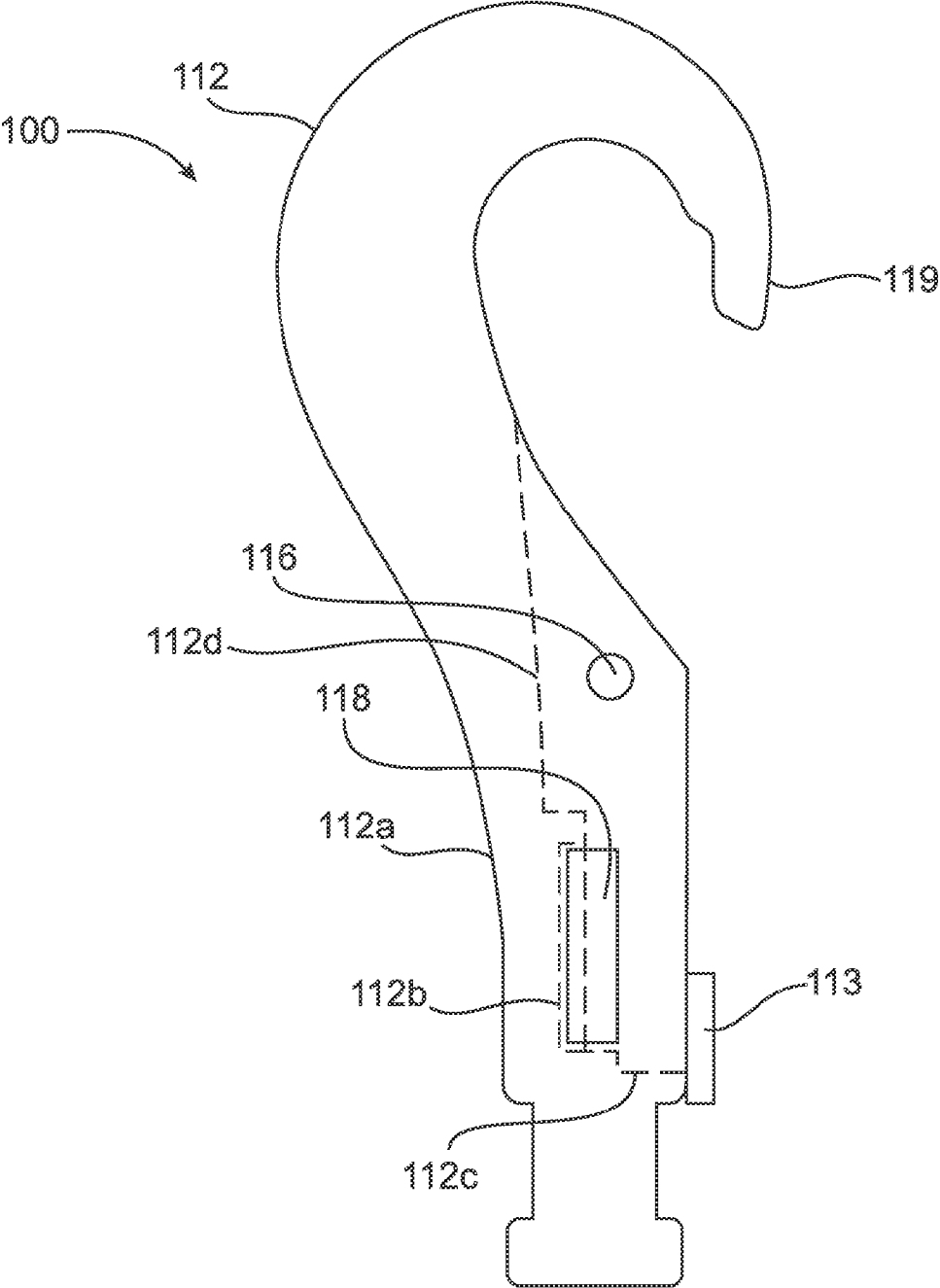

Fig. 9

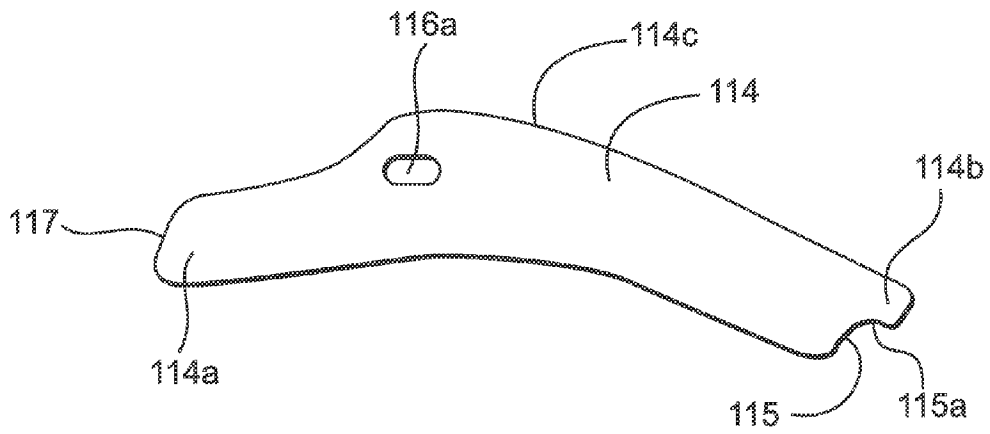

Fig. 10A

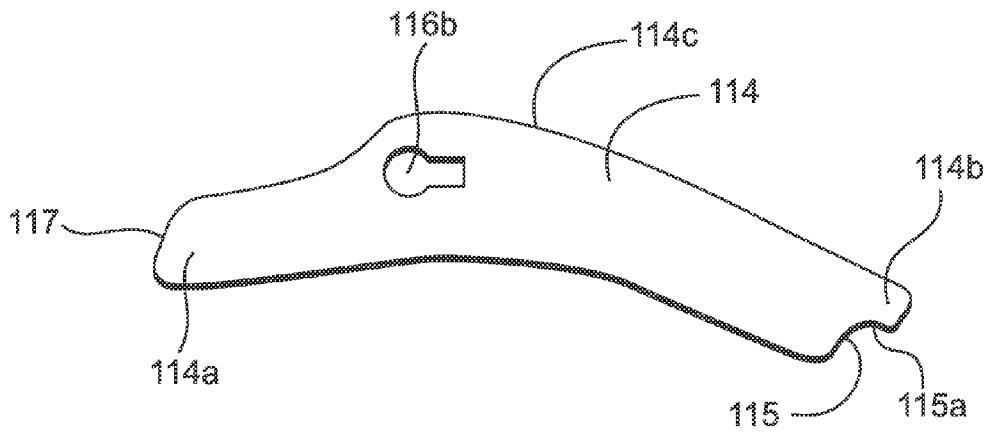

Fig. 10B

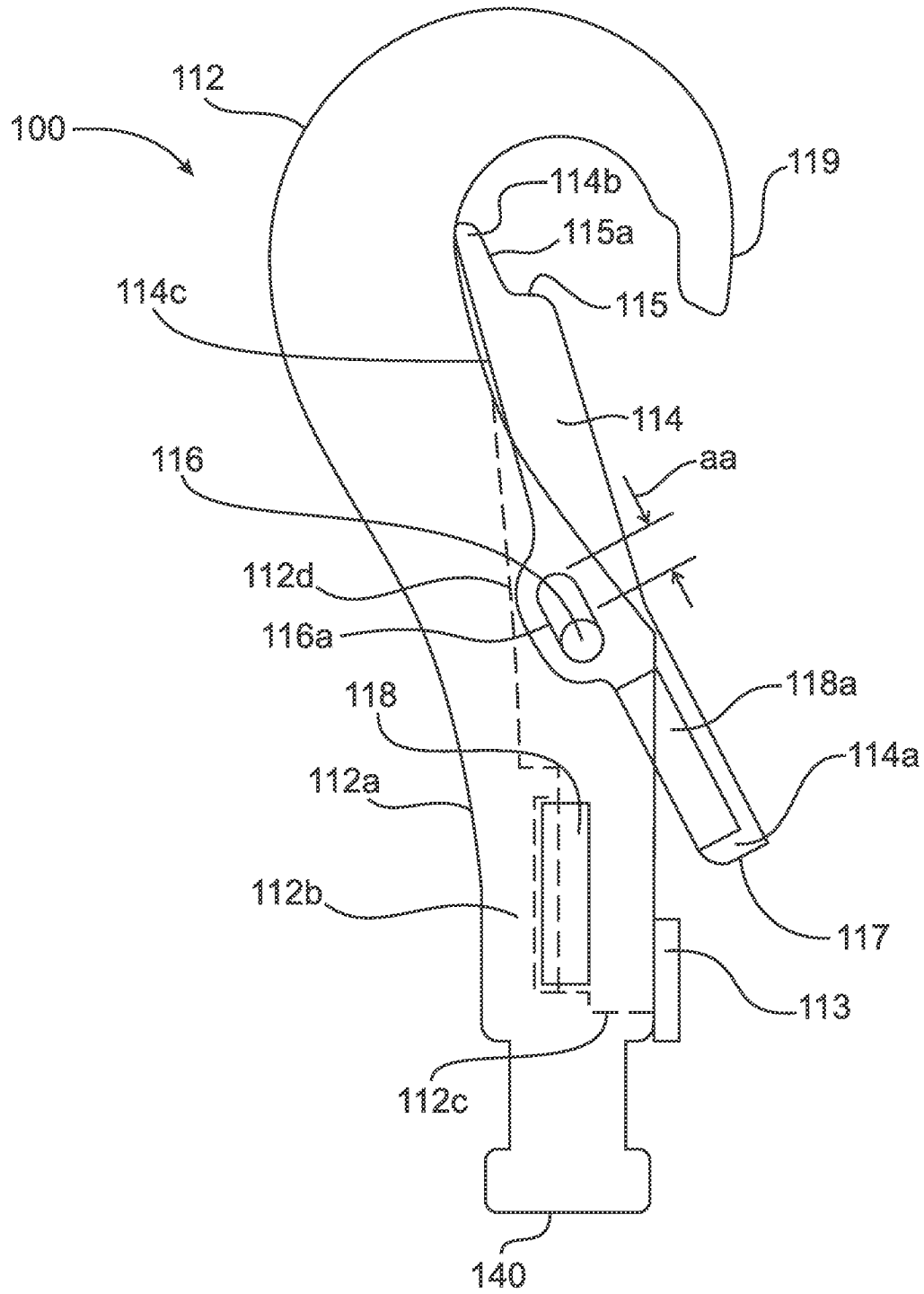

Fig. 13

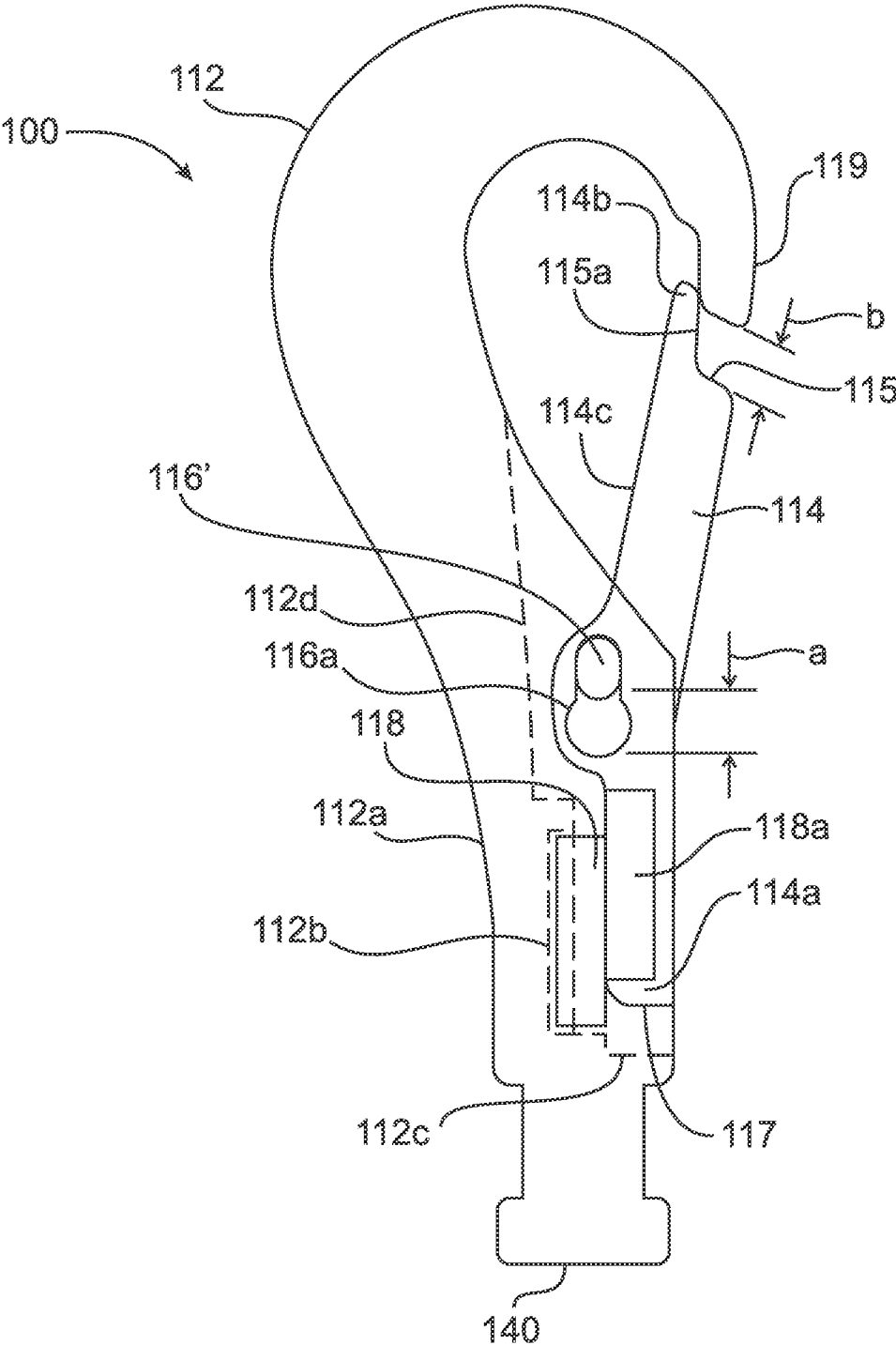

Fig. 14

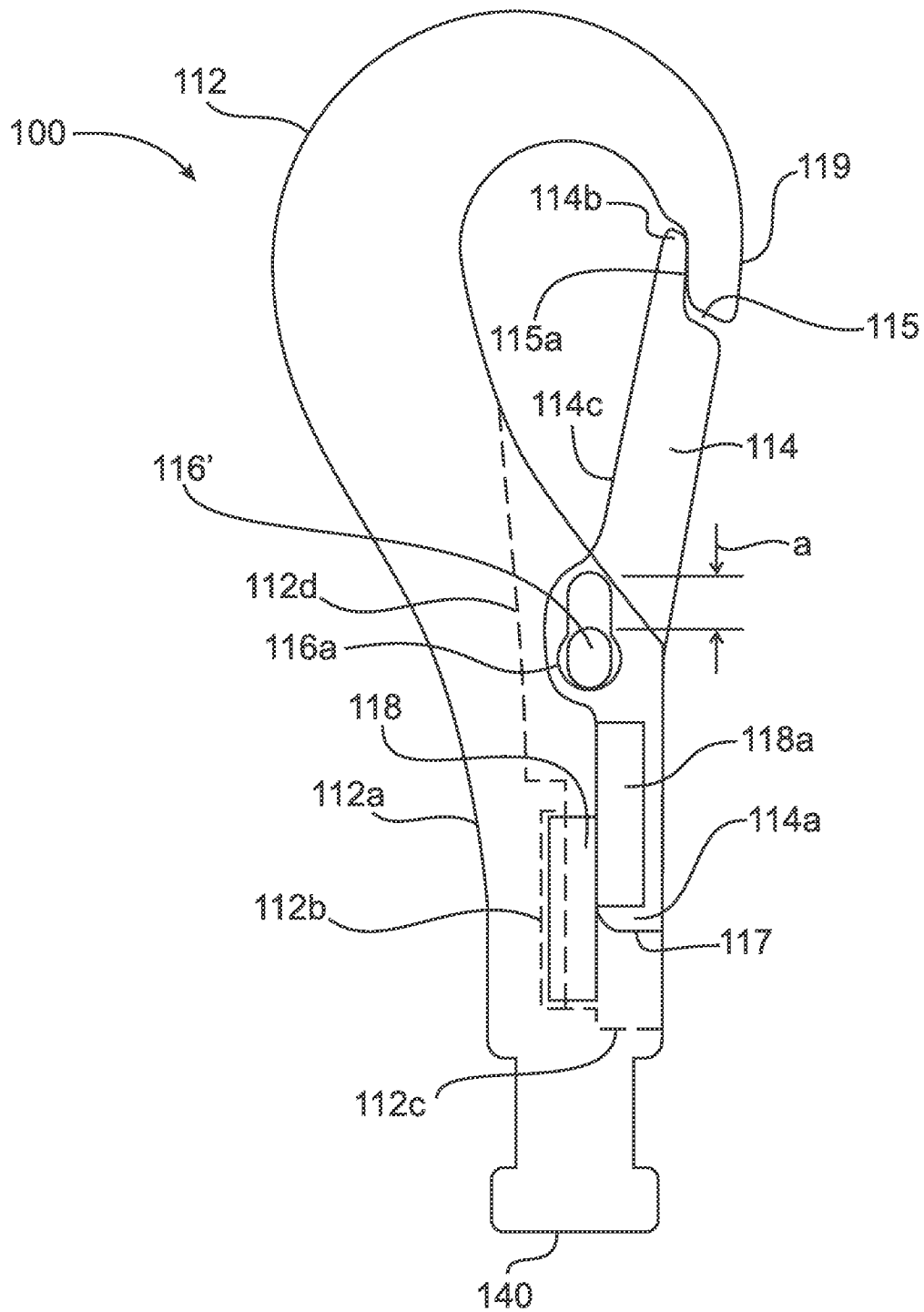

Fig. 15

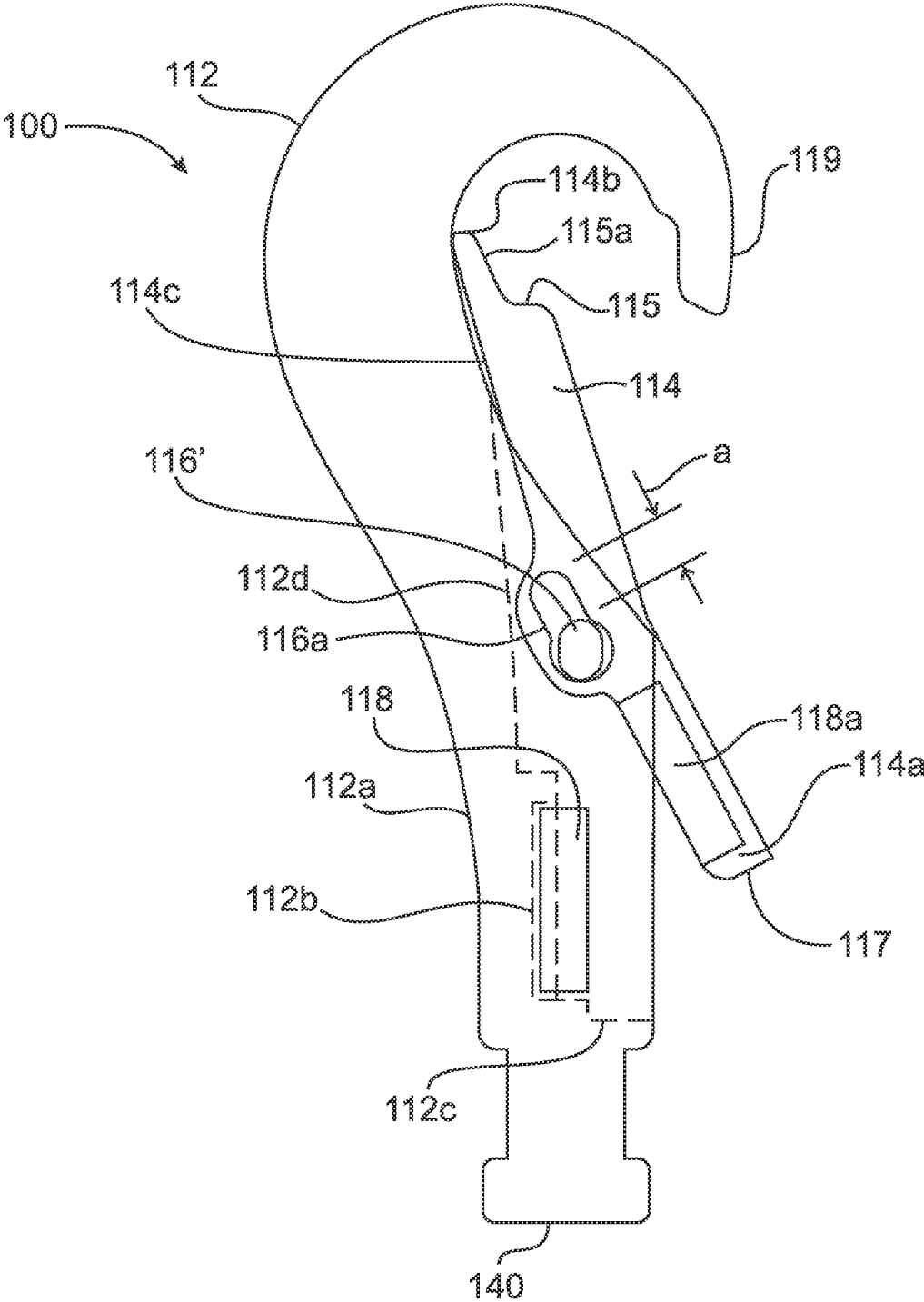

Fig. 16

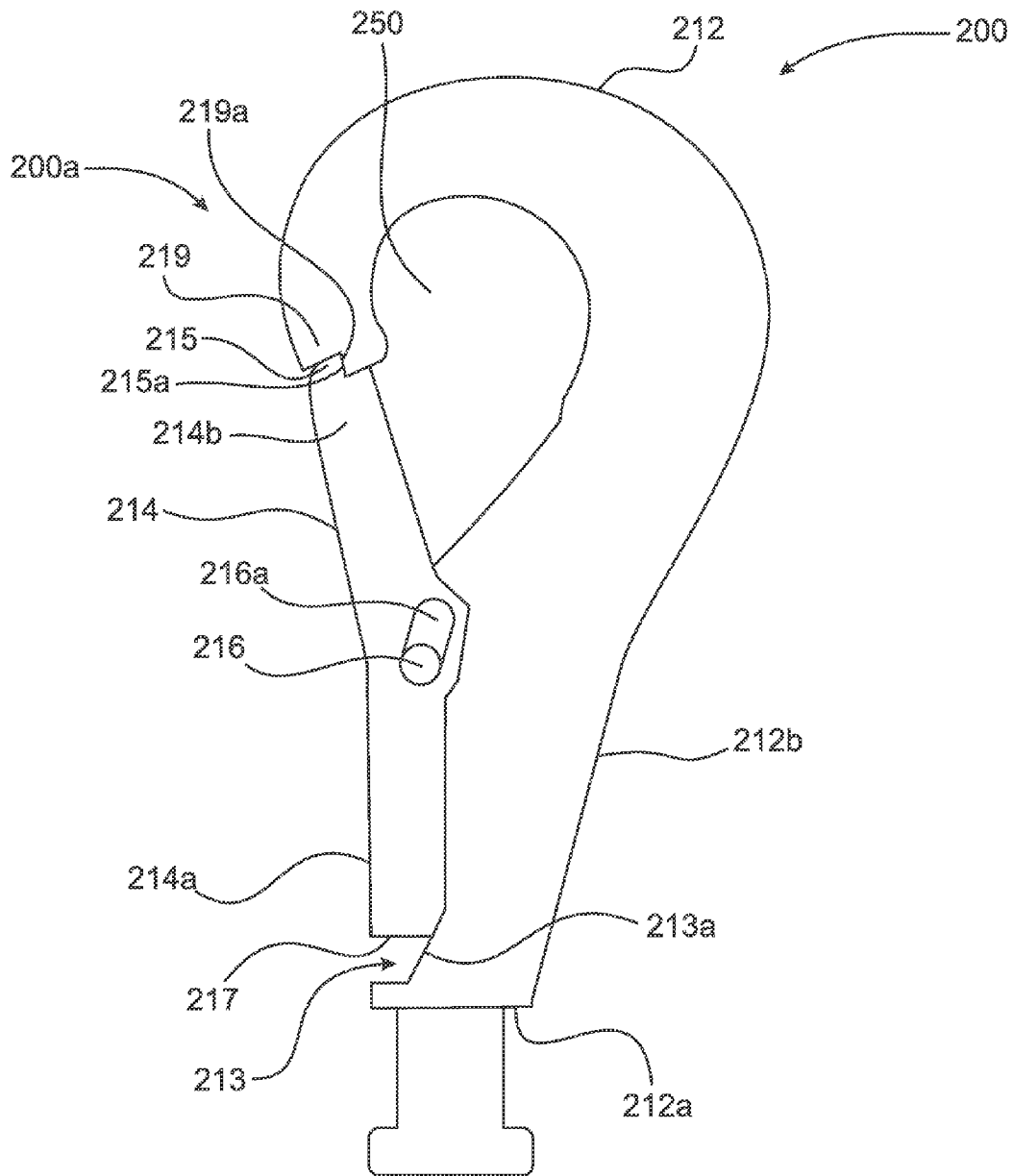

Fig. 17

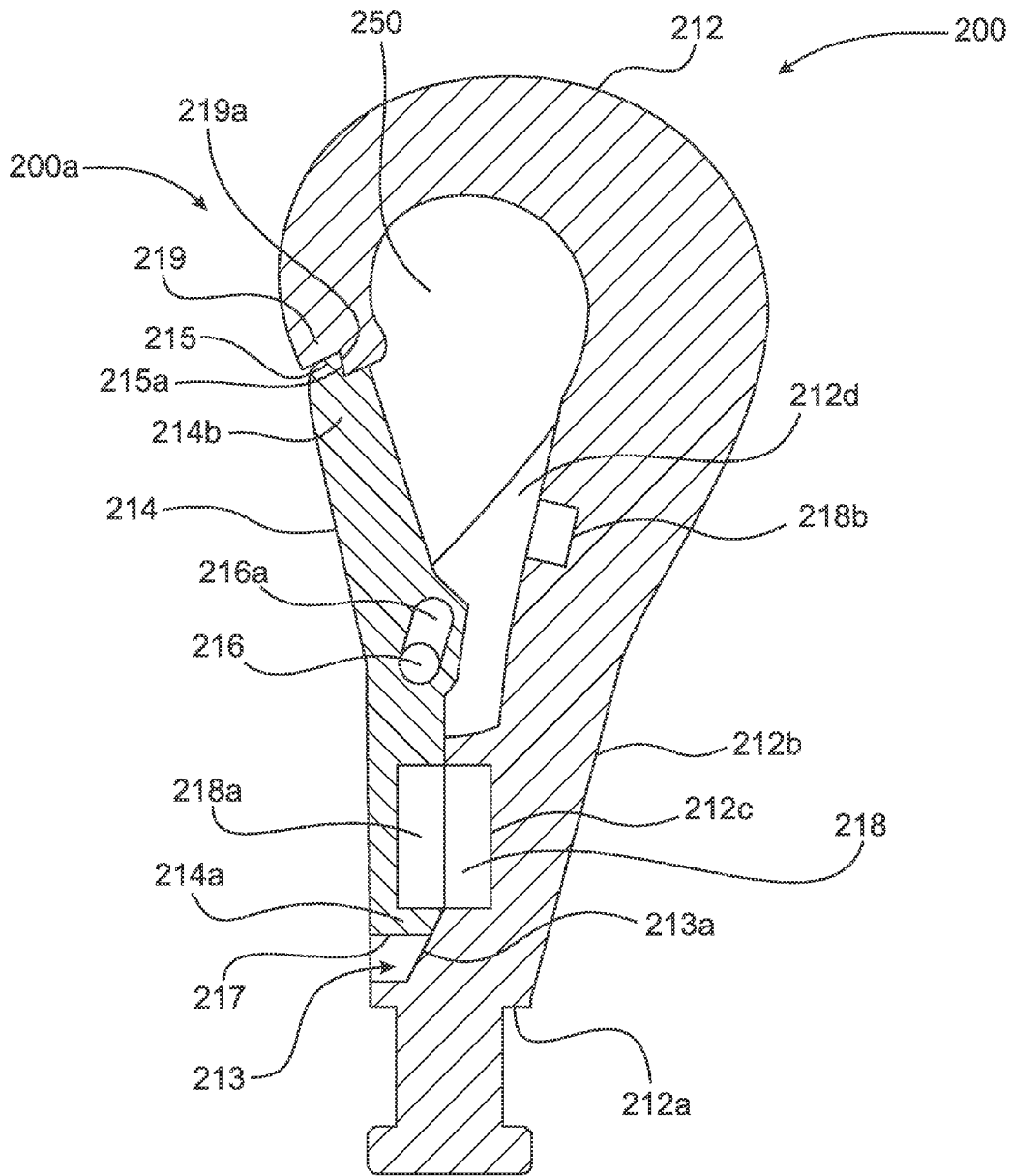

Fig. 18

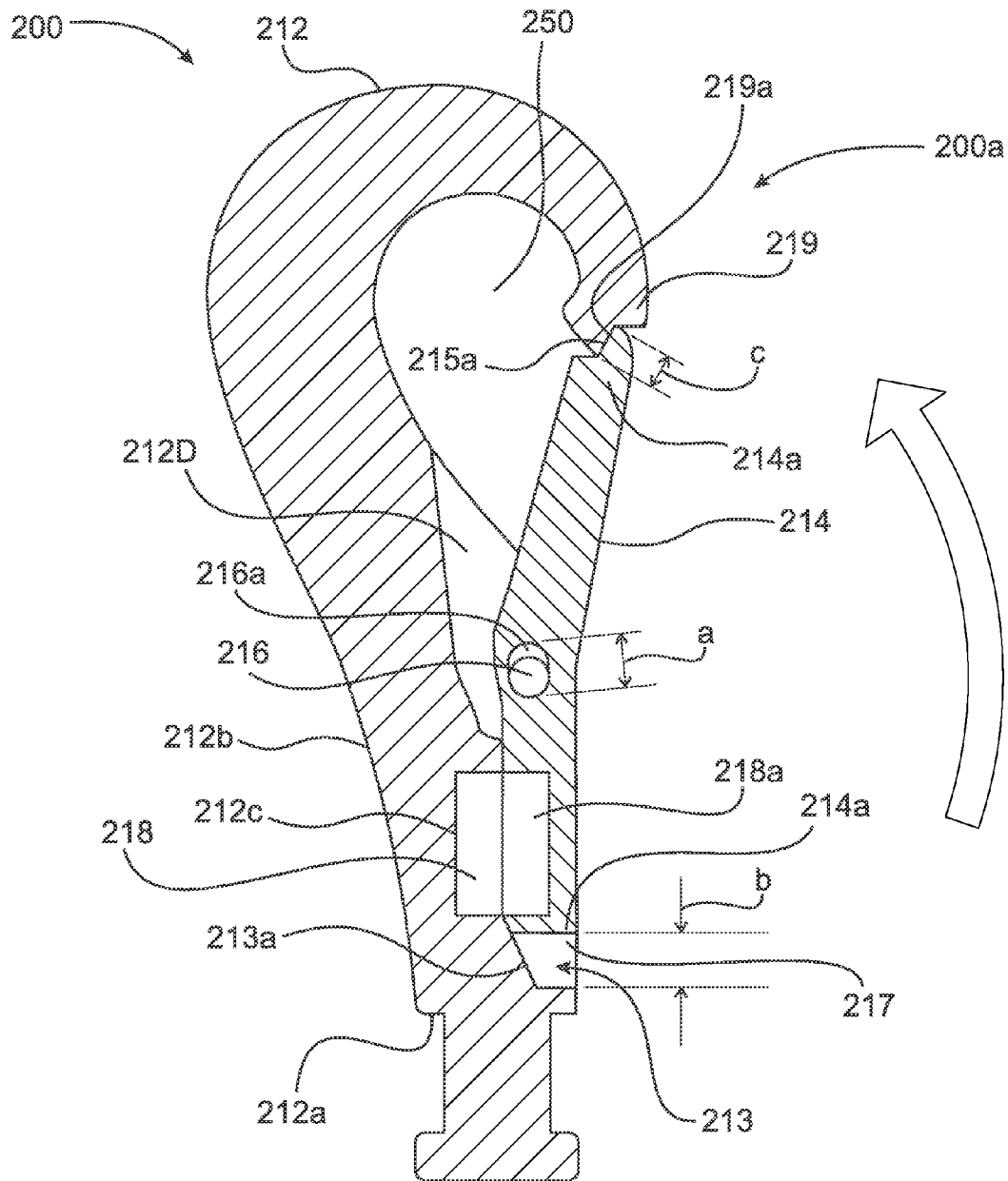

Fig. 19A

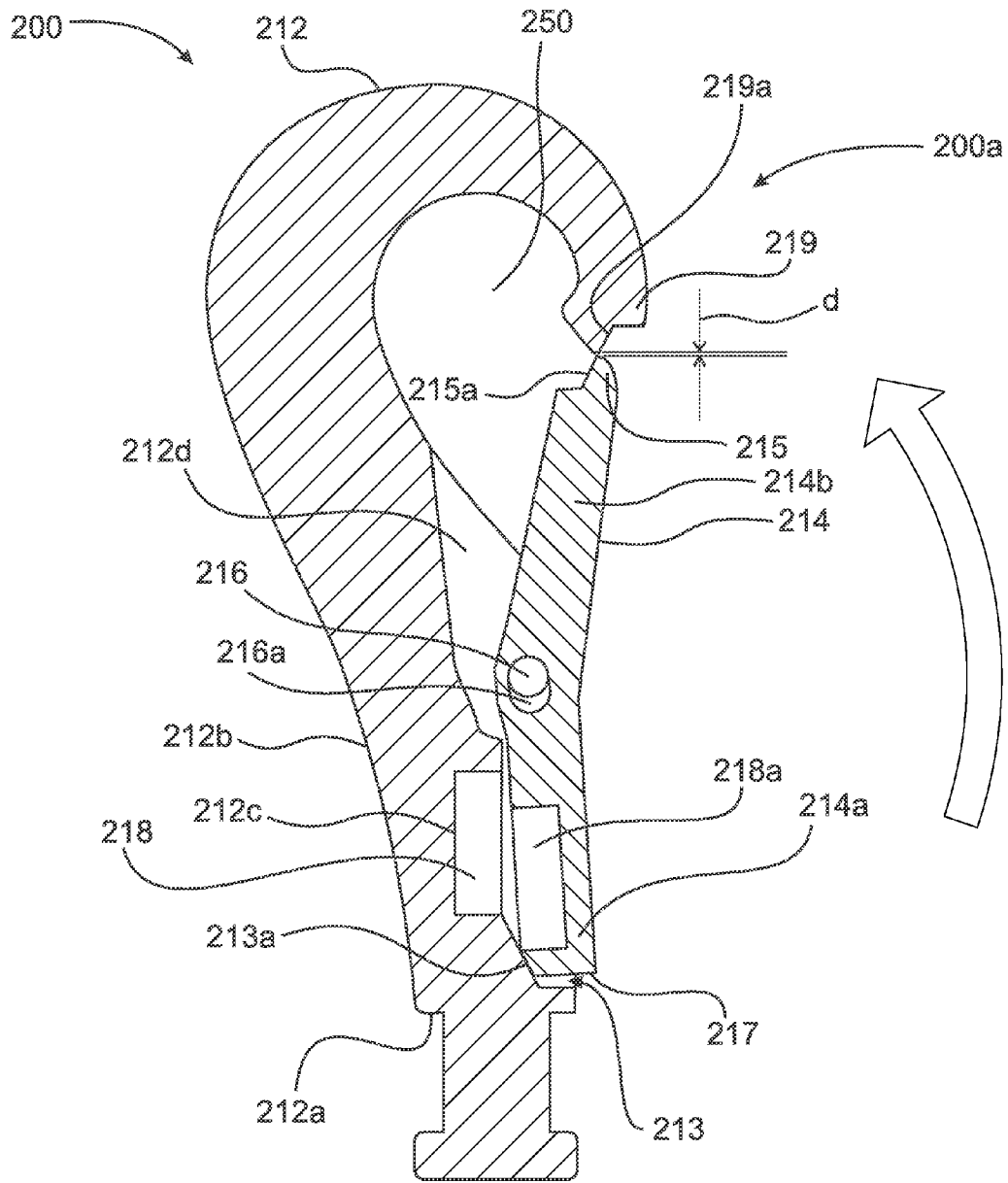

Fig. 19B

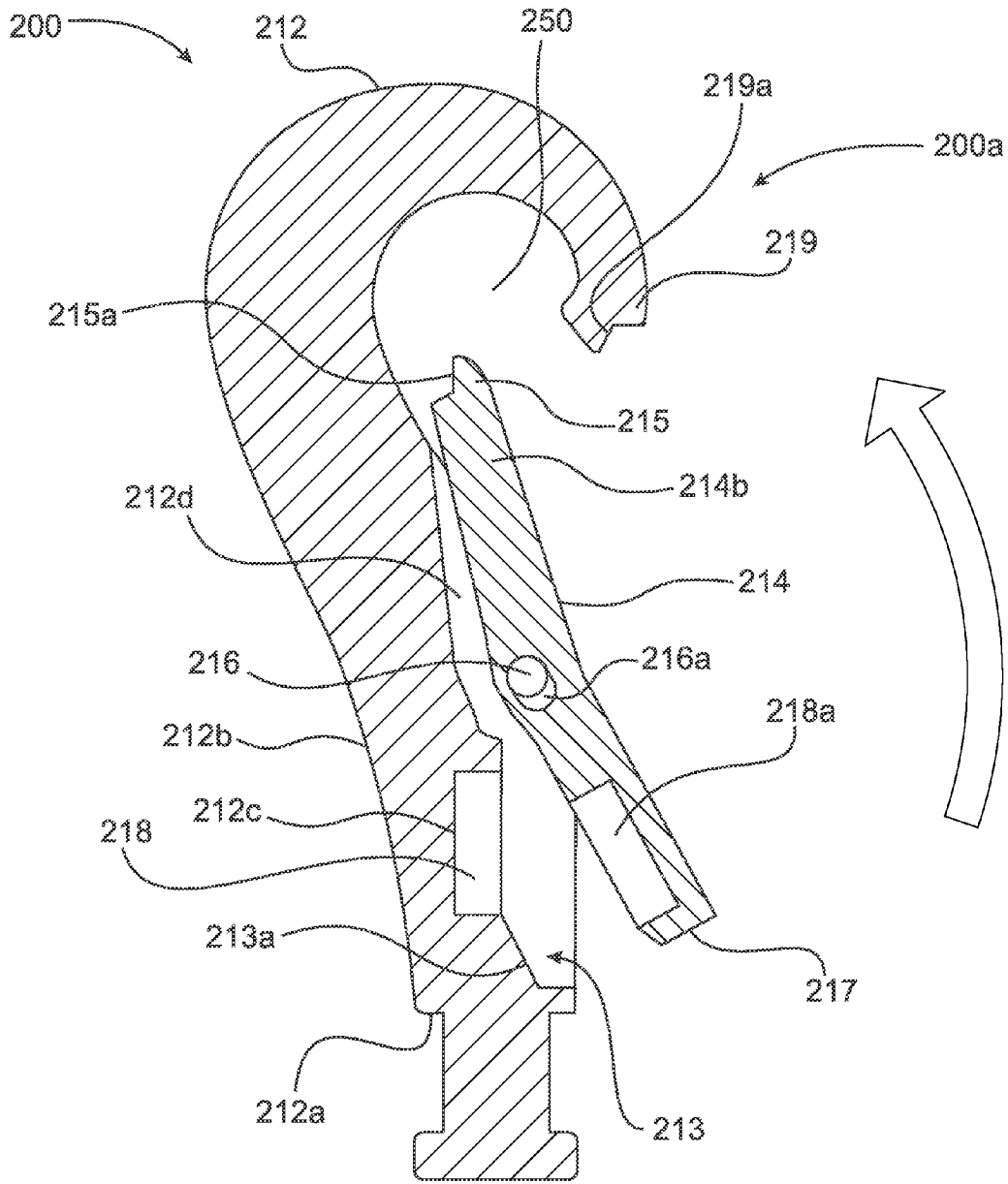

Fig. 19C

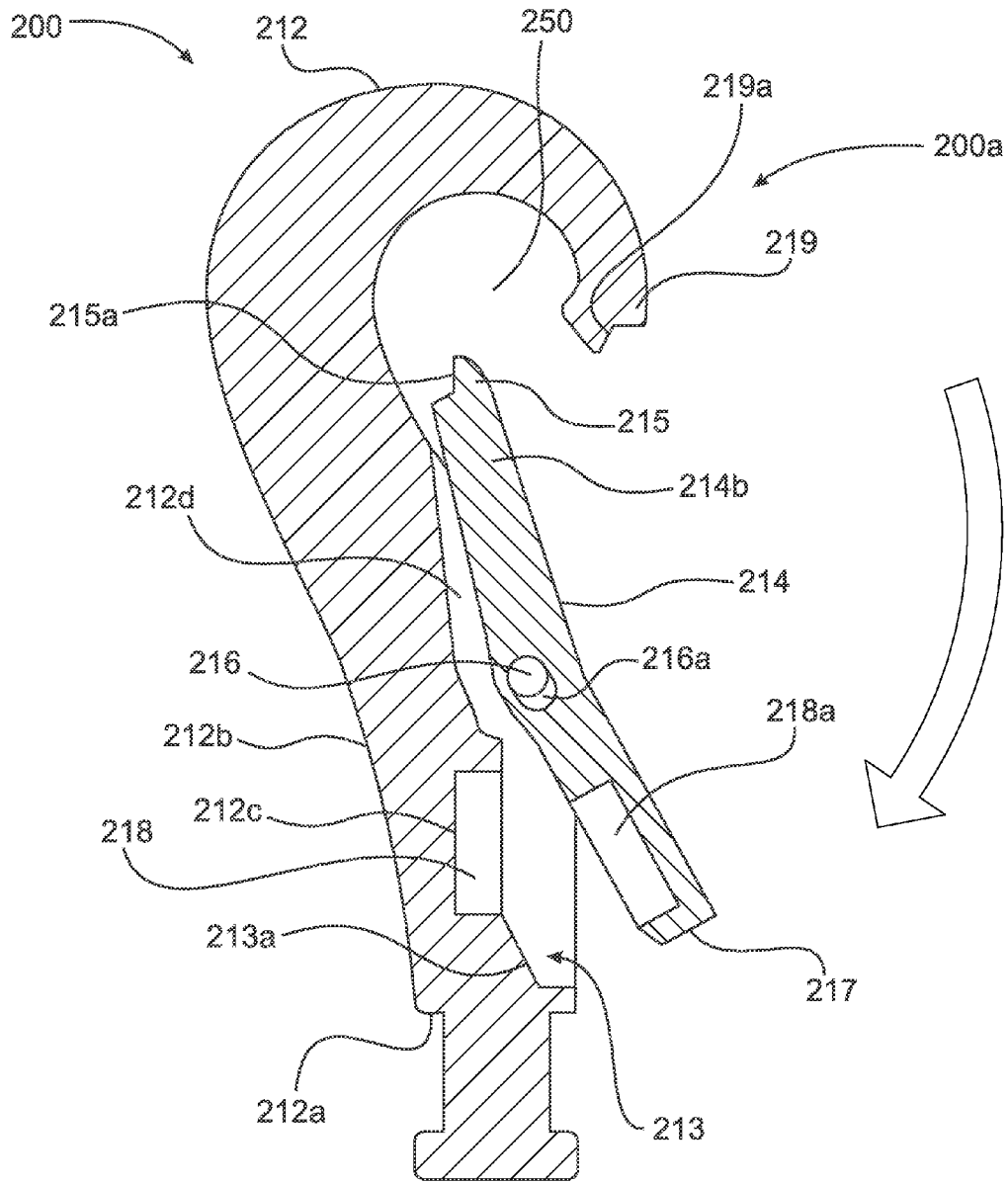

Fig. 20A

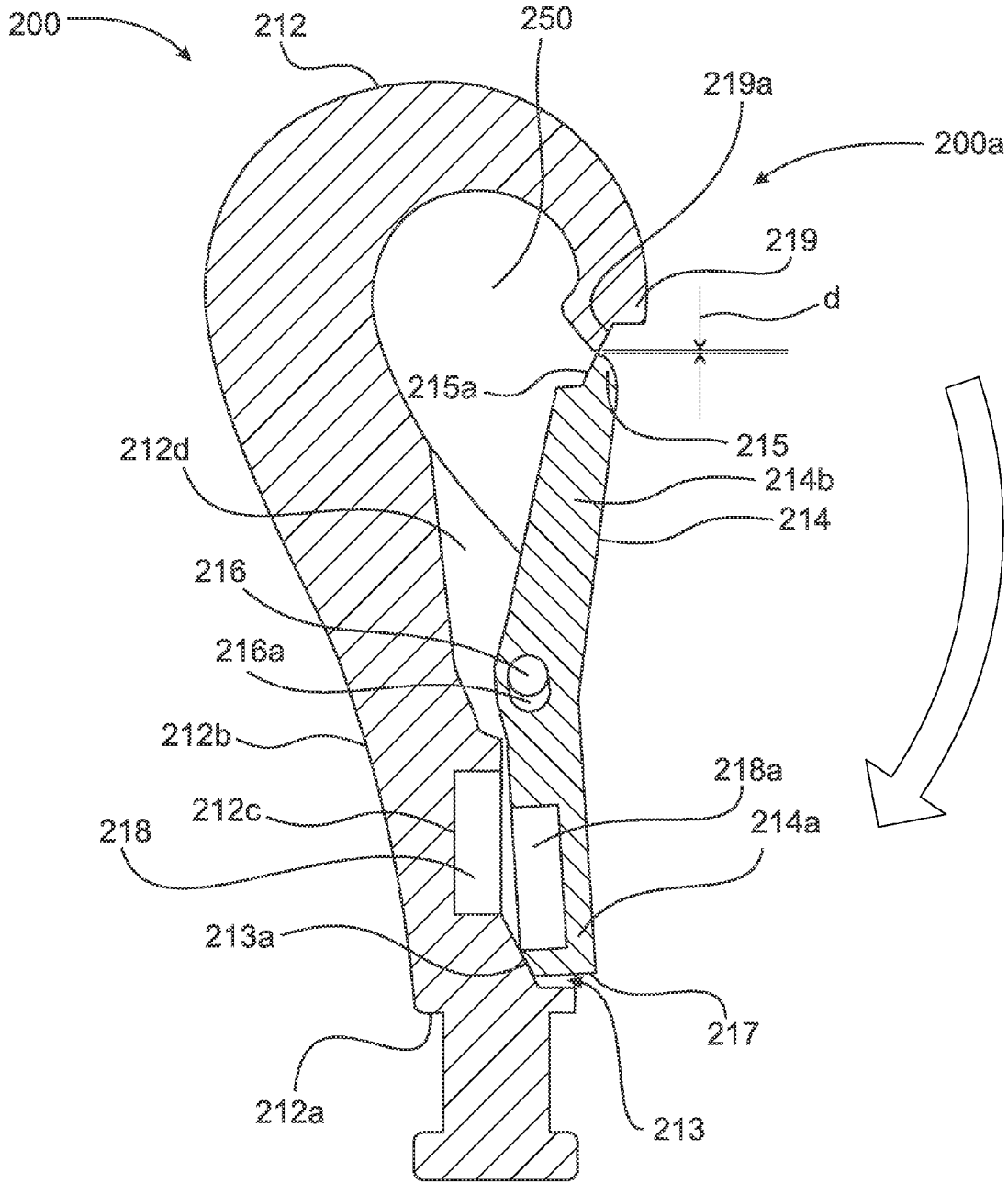

Fig. 20B

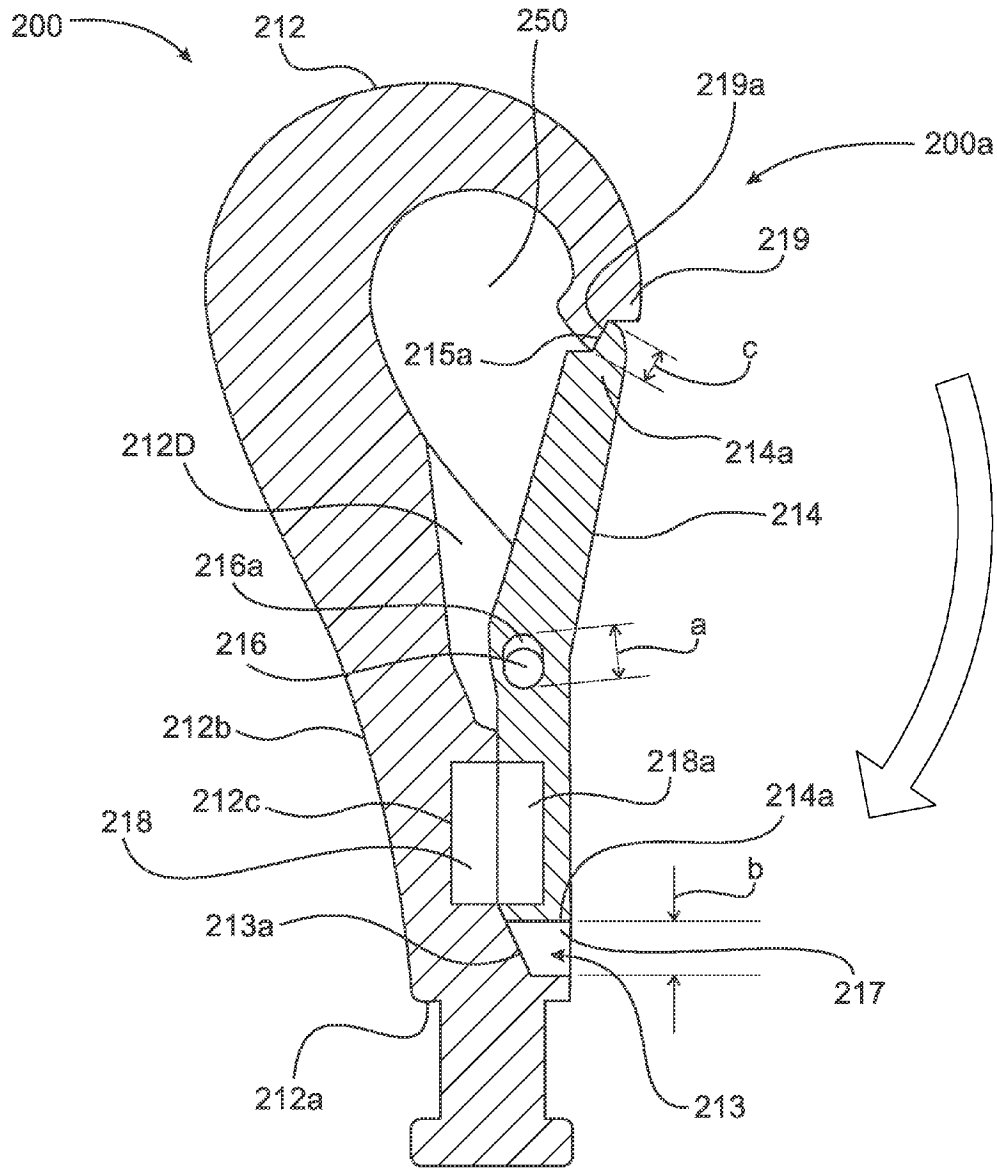

Fig. 20C

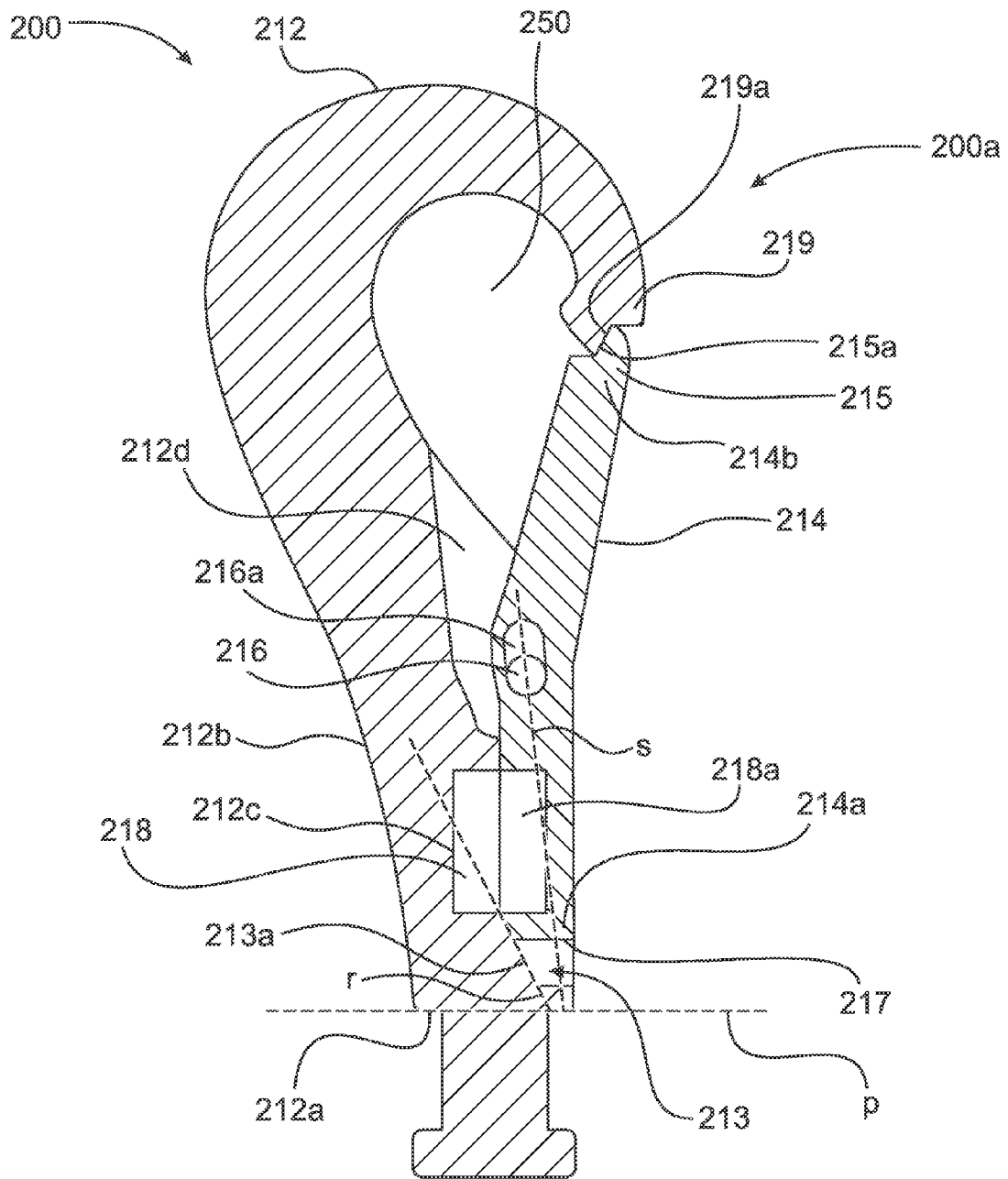

Fig. 21

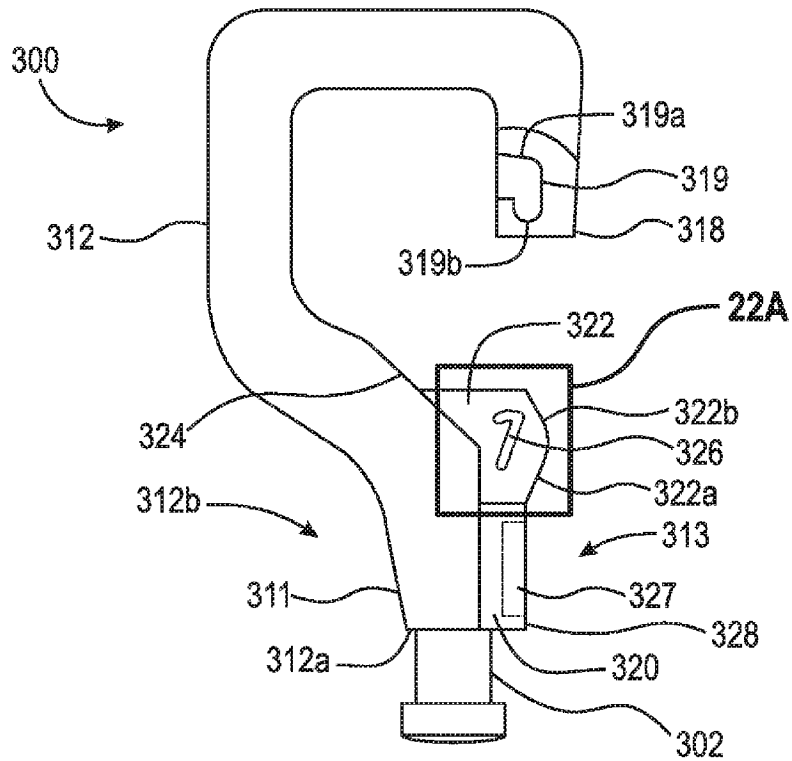

Fig. 22

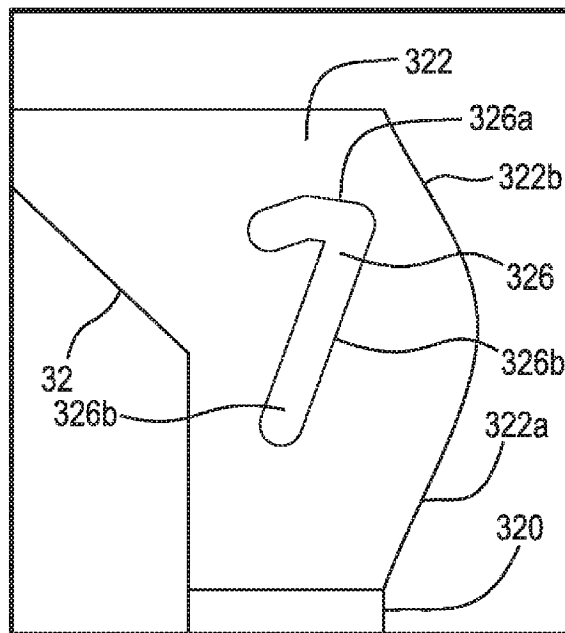

Fig. 22A

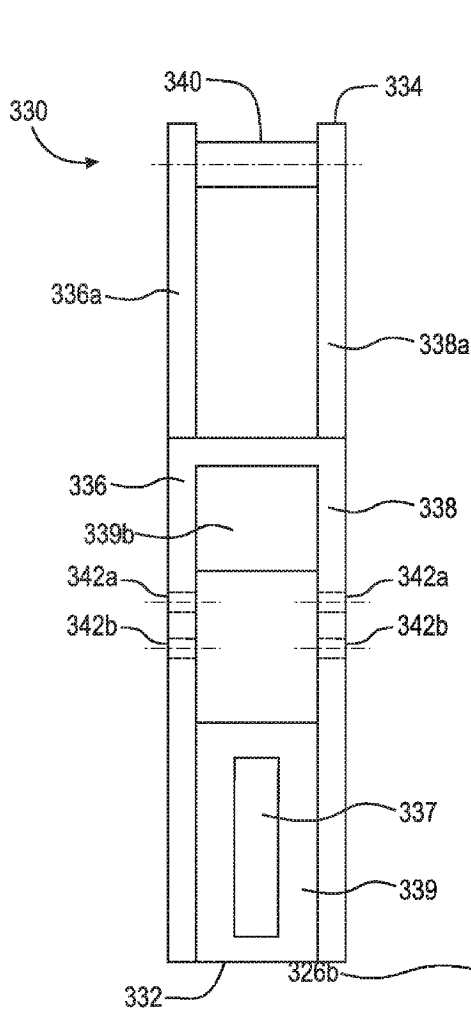

Fig. 23A

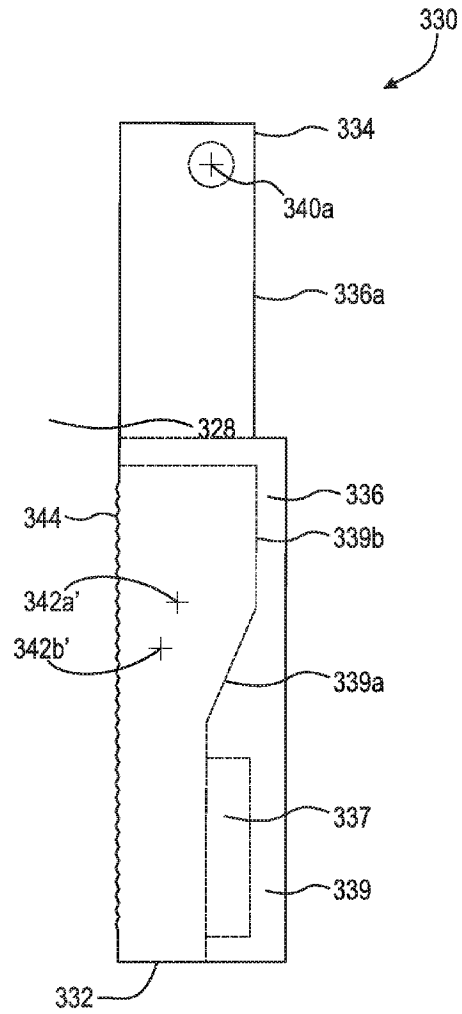

Fig. 23B

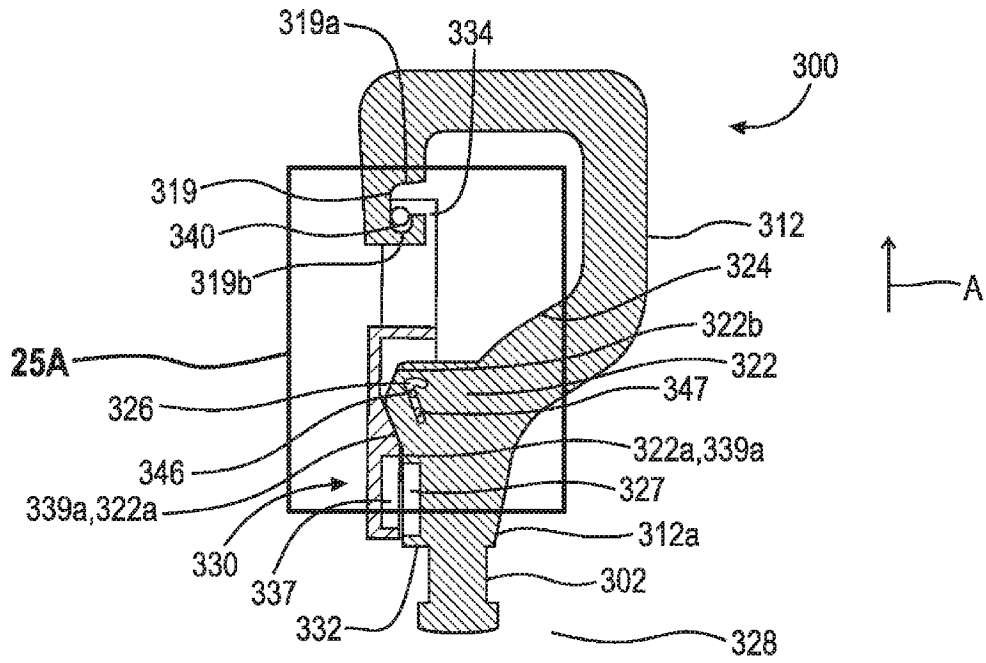

Fig. 25

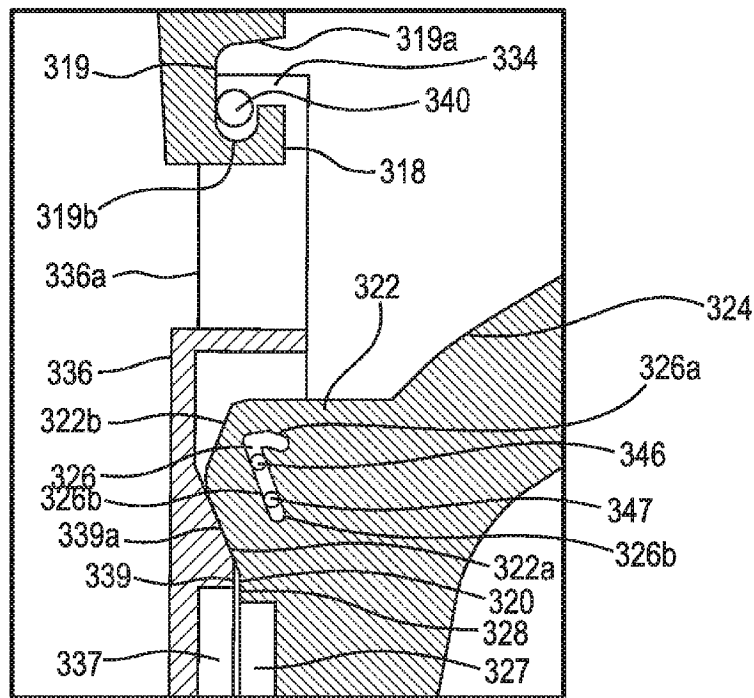

Fig. 25A

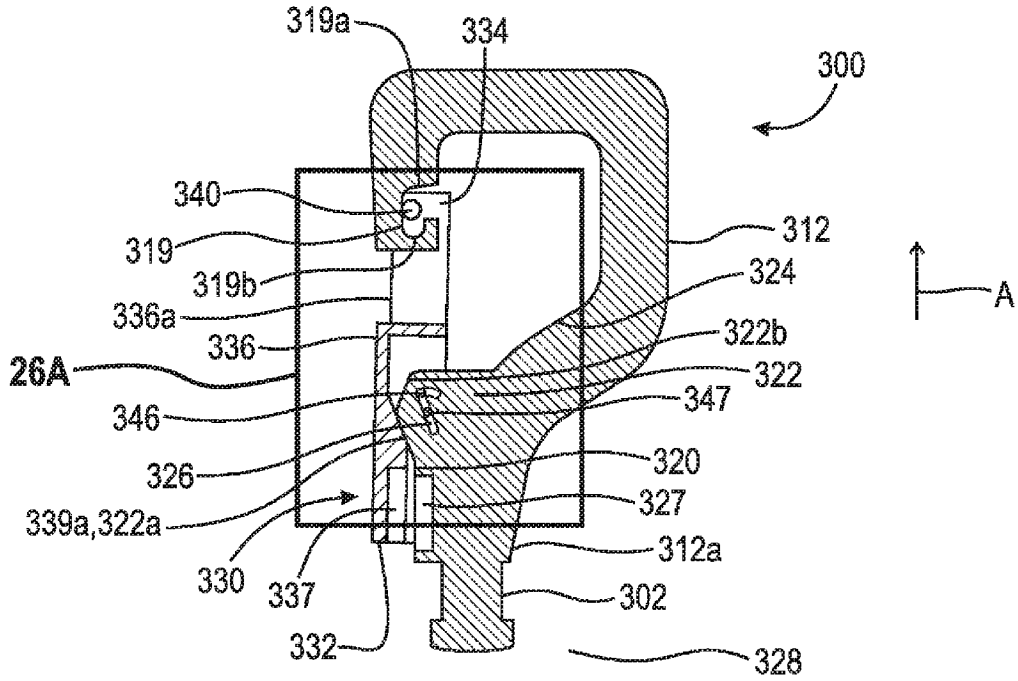

Fig. 26

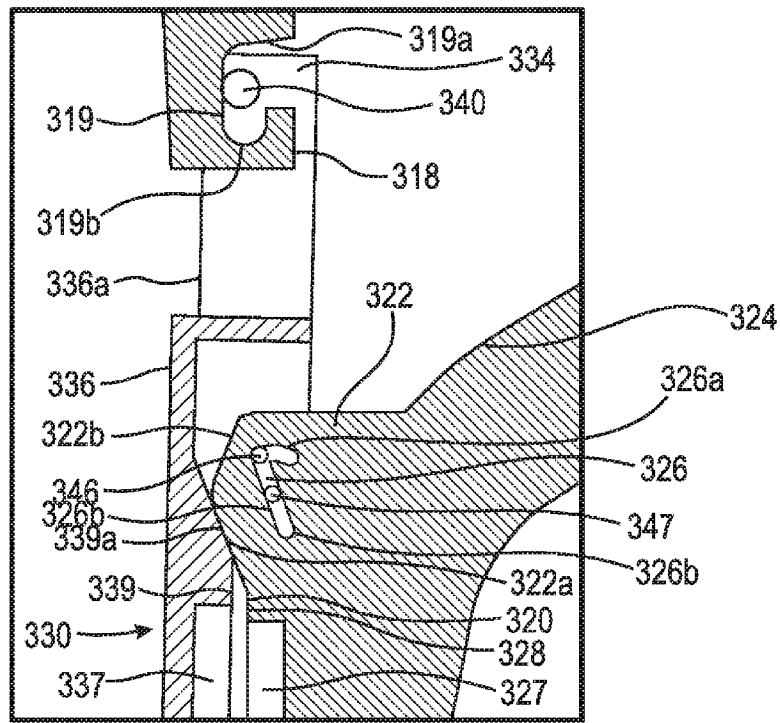

Fig. 26A

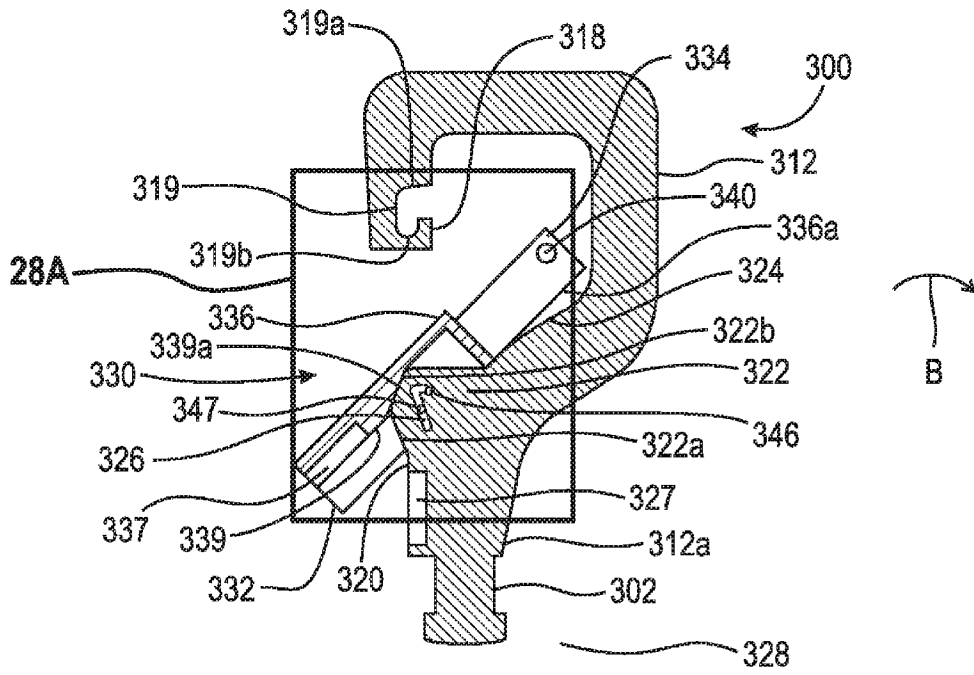

Fig. 28

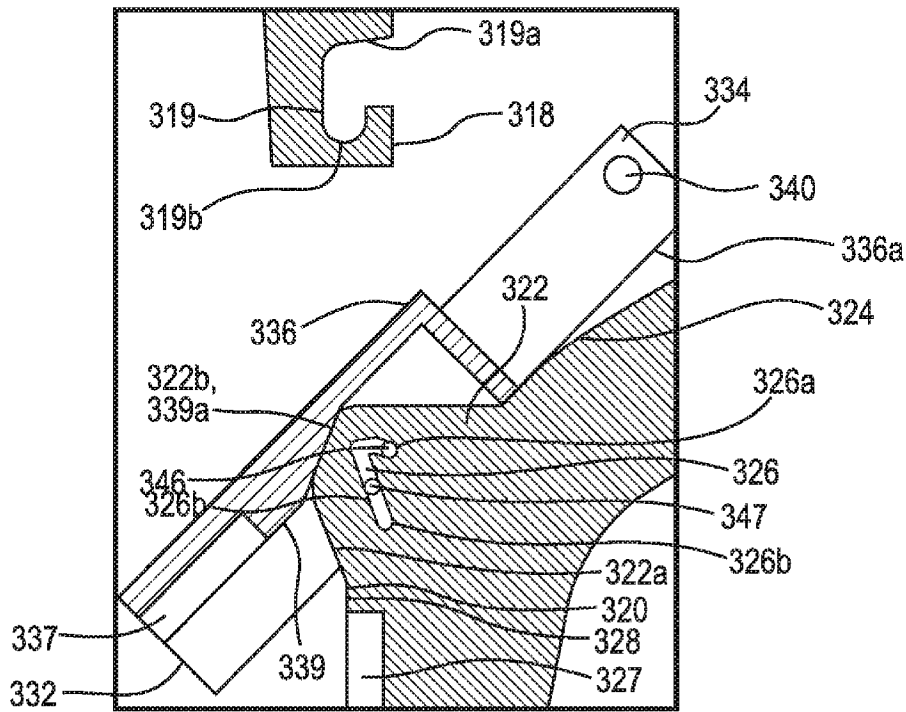

Fig. 28A

1

HOOK WITH MAGNETIC CLOSURE**CROSS REFERENCE TO RELATED APPLICATIONS**

This application is filed under 35 U.S.C. §120 as a continuation-in-part of U.S. patent application Ser. No. 13/947,588, now U.S. Pat. No. 9,032,594, filed Jul. 22, 2013, which application claims priority under 35 U.S.C. §120 as a continuation-in-part to U.S. patent application Ser. No. 13/596,616, now U.S. Pat. No. 9,080,595, filed Aug. 28, 2012, which application claims priority under 35 U.S.C. §120 as a continuation-in-part of U.S. patent application Ser. No. 12/881,744, now U.S. Pat. No. 8,448,307, filed Sep. 14, 2010, which applications are incorporated herein by reference in their entireties.

FIELD OF THE INVENTION

The present invention relates generally to the field of hooks and clasps, specifically to hooks and clasps with a closing mechanism, and more specifically to closures that are manually operated.

BACKGROUND OF THE INVENTION

Manually operated hooks or clasps are found in the prior art that operate using a spring that holds the hook closure closed when the spring is extended. When springs are extended they exert little or no force, meaning that the hook closure is held closed with little or no force. This makes it relatively easy to slightly open the closure to enable the hooked item to slip off the hook. When the closure is opened more completely, the spring exerts progressively more force making the closure harder to open as the spring is compressed. Thus, in prior art hooks of this type, it is harder to purposely open the hook to attach or secure something than it is to accidentally lose something off the hook.

The prior art design tends to cause injuries in that the compressed spring can snap forward unexpectedly injuring the user. In addition, the protruding knob used to pull and hold open the spring is often uncomfortable or even painful to operate.

U.S. Pat. No. 7,441,424 to Saitoh, et al. discloses a clamp that opens similar to a scissors with two arms connected by an off-center pivot pin. The two opposing long arms include a pin to hold a security tag or materials while each of the two short arms includes a magnet of opposing polarity which together hold the clamp in the closed position. The clamp has the disadvantage of not securing an item on the arm and not enabling secure movement of the secured item when the disclosed clamp is closed.

U.S. Patent Application Publication No. 2007/0209168 to Dietz teaches a magnetic spring clip that is attached to an instrument such as a pen or penlight. However, the clip requires that a magnet be in the instrument that is held by the clip thereby introducing a limitation to its usefulness in that nonmagnetic devices cannot be securely held by the clip.

U.S. Patent Application Publication No. 2008/0250615 to Emenheiser teaches a retainer apparatus in the form of a modified hook having a closure that is held in the open position by a magnet. The retainer includes a biasing device to move the closure into the closed position. The Emenheiser retainer requires a trigger to activate the biasing device which, similar to other prior art discussed above, has reduced force to keep the retainer in the closed position. In

2

addition, the use of a trigger mechanism increases the possibility of injury caused by the inadvertent activation of the biasing trigger.

In addition, as mentioned above, the clasps and hooks currently in the field are easily opened accidentally because of the lack of positive force holding the closure in the closed position. The main impediment to overcoming this deficiency is devising a simple structure that not only provides positive closing force to the closure, but can still be easily opened without excessive force and require a minimum number of parts.

Thus, it can be seen there is a need in the field for a hook closure that is easily opened, utilizes a positive force to hold a clasp or hook in the closed position around a hook type of device, and prevents or reduces accidental opening of the clasp or hook.

SUMMARY OF THE INVENTION

The present invention broadly comprises a hook comprising: a body having a neck and formed into a hook shape and fabricated from nonferromagnetic material with the body having a first end and a second end. The neck is proximate the first end. The hook also comprises a closure having a first closure end and a second closure end that is fabricated from nonmagnetic ferromagnetic material, the closure being centrally pivotally attached to the body and positioned to span a space between the second end of the hook and the body. There is at least one magnet fixedly attached to the neck, wherein the at least one magnet holds the closure in a closed position that spans the gap such that the hook encloses a defined space in the closed position.

In an alternate embodiment, the present invention broadly comprises a body having a neck and formed into a hook shape and fabricated from nonferromagnetic material, the body having a first end and a second end wherein the neck is proximate to the first end; a pin centrally attached to the body; a closure having a first closure end and a second closure end and fabricated from nonmagnetic ferromagnetic material, the closure having a slot and pivotally and slidably attached to the pin and positioned to span a space between the second end and the body in a closed position; a neck groove formed in the neck to receive the first closure end and including a groove wall proximate the first body end; a lip extending from the body and facing the neck groove, the lip maintaining the closure in the closed position; at least one neck magnet fixedly attached to the neck groove; and, at least one closure magnet fixedly attached to the closure proximate the first closure end. The at least one neck magnet and the at least one closure magnet are offset from each other and possess opposite polarity and hold the closure in the closed position. The hook encloses a defined area in the closed position.

In a second alternate embodiment the present invention broadly comprises a hook comprising: a body formed into a hook shape and fabricated from nonferromagnetic material, the body having a first hook end and a second hook end, a neck, and an angled portion in which the neck is proximate to the first hook end; a center ridge extending along one side of the neck, one end of the center ridge forming a flange that reaches to the angled portion, with the center ridge having a flat top surface and an angled slot is defined by the flange and has two legs. The hook also includes comprises a closure having a first closure end and a second closure end and a first lateral side and a second lateral side, each lateral side extending the length of the closure; a channel having a floor and extending at least partly between the lengths of the first

3

lateral side and the second lateral side. at least one pin rotatably attached to the first and second lateral sides; a bridge proximate to the second closure end and attached to the first and second lateral sides. A first magnet is attached to either the top surface of the center ridge proximate to the first hook end or the floor of the channel proximate the first closure end. The at least one pin is slidably engaged with the slot; and the hook encloses a defined area in a closed position. Preferably the hook includes a second magnet positioned opposite the first magnet.

The hook encloses a defined area in the closed position.

One object of the invention is to provide a hook that uses magnetic force to keep the closure in a closed position.

A second object of the invention is to replace a biasing spring to hold a closure in place with a magnetically closed closure.

A third object of the invention is to provide a hook that is safe to use and easy to open.

Another object is to demonstrate a hook that is safer to use than the prior art.

An additional object of the invention is to provide a hook in which the closing force is becomes stronger as the closure approaches the closed position.

A further object is to supply a locking mechanism for the hook.

A still further object of the invention is to offer a hook devised to decrease or prevent accidental openings while simultaneously configured to open easily.

An additional object of the invention is to supply a hook configured to include features that provide stability while the hook is held in the open position.

BRIEF DESCRIPTION OF THE SEVERAL VIEWS OF THE DRAWINGS

The nature and mode of the operation of the present invention will now be more fully described in the following detailed description of the invention taken with the accompanying drawing Figures, in which:

FIG. 1 is a side view of the hook of the present invention;

FIG. 2 is a side perspective view of the hook of the present invention;

FIG. 3 is a bottom view of the hook showing the closure in the closed position;

FIG. 4 is a cross section of the hook taken along line 4-4 of FIG. 3;

FIG. 5 is a bottom perspective of the present invention depicting the receiving groove formed into the body of the hook;

FIG. 6 is a side view of the hook demonstrating the closure in the open position forming a space between the second end of the hook and the body of the hook;

FIG. 7A is a top perspective view of the hook in the open position;

FIG. 7B is a side perspective view of the hook in the open position;

FIG. 8 is a top perspective view of the hook of the present invention securing a loop with the closure in the closed position;

FIG. 9 is a side view of a second embodiment of the hook of the present invention without a closure and including a lip opposite the neck groove;

FIG. 10A is a side view of one embodiment of the closure of the hook seen in FIG. 9 in which the pivot slot is oval-shaped;

FIG. 10B is a side view of an alternate embodiment of the closure in which the slot is keyhole shaped;

4

FIG. 11 is a side view of the second embodiment of the hook depicting the closure in the closed position i.e., spanning the space between second closure end and the hook body;

FIG. 12 is a side view of the second embodiment of the hook in which the closure is pushed forward off the lip;

FIG. 13 is a side view of the hook showing the closure in the open position;

FIG. 14 is a side view of the second embodiment of the hook similar to FIG. 9 showing alternate embodiments of the closure slot and the pivot;

FIG. 15 is a side view of the hook seen in FIG. 14 showing the closure pushed toward the second hook end; and,

FIG. 16 depicts the hook with the closure having the keyhole slot in the open position;

FIG. 17 is side view of an additional embodiment of the hook of the present invention;

FIG. 18 is a side cross section view of the embodiment of the hook first seen in FIG. 17;

FIG. 19A is a side cross section view showing the hook in the closed position;

FIG. 19B shows the hook as the closure moves from the closed to the completely open position;

FIG. 19C depicts the hook as it approaches the open position;

FIG. 20A shows the hook returning to the closed position as shown by the arrows;

FIG. 20B shows the hook with the offset clearing the second hook end at the same time the first closure end and the closure edge return to the gap;

FIG. 20C depicts the hook returned to the closed position seen in FIG. 19A; and,

FIG. 21 depicts the relative angles of the ramp in the hook body and the slot in the closure;

FIG. 22 is a side view of a second additional embodiment of the hook of the present invention;

FIG. 22A is an enlarged side view of the portion of FIG. 22 enclosed in area 22A;

FIG. 23A is a front view of the closure for the hook of the second additional embodiment of the present invention;

FIG. 23B is a side view of the closure seen in FIG. 23A;

FIGS. 24-28A are lengthwise cross section views depicting the movement of the closure relative to the hook body when the hook is opened;

FIG. 24 depicts hook 300 in the closed position;

FIG. 24A is an enlarged view of area 24A of FIG. 24;

FIGS. 25 and 25A show the first movement of the closure during the opening of the hook;

FIGS. 26 and 26A portray the position of the closure relative to the hook when the first pin reaches the end of the long slot leg;

FIGS. 27 and 27A depict the rotational movement of the closure relative to the hook body when the bridge is moved out of the j-hook; and,

FIGS. 28 and 28A depict the position of the closure relative to the hook body when the closure is completely opened.

DETAILED DESCRIPTION OF EMBODIMENTS OF THE INVENTION

At the outset, it should be appreciated that like drawing numbers on different drawing views identify identical structural elements of the invention. It also should be appreciated that figure proportions and angles are not always to scale in order to clearly portray the attributes of the present invention.

While the present invention is described with respect to what is presently considered to be the preferred embodiments, it is understood that the invention is not limited to the disclosed embodiments. The present invention is intended to cover various modifications and equivalent arrangements included within the spirit and scope of the appended claims.

Furthermore, it is understood that this invention is not limited to the particular methodology, materials and modifications described and as such may, of course, vary. It is also understood that the terminology used herein is for the purpose of describing particular aspects only, and is not intended to limit the scope of the present invention, which is limited only by the appended claims.

Unless defined otherwise, all technical and scientific terms used herein have the same meaning as commonly understood to one of ordinary skill in the art to which this invention belongs. It should be appreciated that the term "substantially" is synonymous with terms such as "nearly", "very nearly", "about", "approximately", "around", "bordering on", "close to", "essentially", "in the neighborhood of", "in the vicinity of", etc., and such terms may be used interchangeably as appearing in the specification and claims. Although any methods, devices or materials similar or equivalent to those described herein can be used in the practice or testing of the invention, the preferred methods, devices, and materials are now described. It should be appreciated that the term "proximate" is synonymous with terms such as "nearby", "close", "adjacent", "neighboring", "immediate", "adjoining", etc., and such terms may be used interchangeably as appearing in the specification and claims.

Adverting to the drawings, FIG. 1 is a side view of hook 10. Hook 10 is attached to ring 40 by attachment 11. Attachment 11 is shown as a swivel attachment that allows hook 10 to move through an arc. Persons of ordinary skill in the art will recognize that other types of attachments 11 are suitable to hold ring 40 to hook 10. Examples of such attachments include, but are not limited to, pivot attachments as with ball and socket attachments and solid attachments. Examples of ring 40 include, but are not limited to, o-rings, d-rings, chain attachments, handles, etc.

First end 15 of hook 10 is attached to attachment 11. Neck 12a extends from first end 15 and is preferably integral with body 12. By integral is meant that the component parts are formed together as a single unit. Preferably, hook 12 is fabricated from nonferromagnetic material. By ferromagnetic is meant material that it is attracted to magnets. Therefore, the term "nonferromagnetic" describes material that is not attracted to magnets. Body 12 is shaped into a hook having second end 19 at the end of the hook. Body 12 is shown as having a curved shape. It will be recognized that body 12 may have a straight body shape between neck 12a and the curved portion of the hook forming a j-shaped hook.

Closure 14 is pivotally attached to body 12 using pivot 16 and is preferably fabricated from nonmagnetic ferromagnetic material. Pivotal attachment 16 enables closure 14 to open and close by rotating on pivot 16. Pivot attachment 16 is substantially in the center of closure 14. When closure 14 is in the closed position, it spans the space between second end 19 and body 12 of hook 10. In a preferred embodiment, second closure end 14b and second end 19 are each configured to form a mating type fit an example of which is seen in FIG. 1.

In a preferred embodiment shown in FIG. 1, body 12 and neck 12a are formed to receive closure 14 in both the open and closed positions, respectively. Neck 12 is formed to include neck groove 12b which receives first closure end 14a when closure 14 is moved to the closed position

extending to second end 19 of hook 10 to decrease the size of neck 12a. In the open position, receiving groove 13 in body 12 (not seen in FIG. 1) receives closure 14 when it is rotated away from second end 19 through space 50 to body 12. Preferably, closure 14 includes region 14c which contacts receiving groove 13 when closure 14 is opened. Preferably, region 14c is formed, for example flattened, to matingly fit into receiving groove 13 to increase the size of space 50 when closure 14 is opened. The size will be increased as a reduced volume of closure 14 will extend into space 50 in the open position. FIG. 2 is a side perspective view of hook 10 showing more clearly region 14c.

FIG. 3 is a bottom view of hook 10 showing closure 14 in the closed position. FIG. 4 is a cross section taken along line 4-4 of FIG. 3. Neck magnet 18 is seen fixedly attached to neck 12a, preferably so as to have a surface exposed in neck groove 12b. While the manner of fixed attachment shown in FIG. 4 is embedding, it will be recognized that other forms of fixed attachment may be used, such as, but not limited to, adhesives and press fit or friction fit into a recess. FIG. 4 also depicts an alternate embodiment in which closure magnet 18a is embedded so as to be exposed on the surface of first closure end 14a opposite neck magnet 18. In this embodiment, magnet 18a will be of the opposite polarity of magnet 18 thereby providing increased attractive magnetic force holding closure 14 in the closed position. Preferably, the strength of neck magnet 18 and/or closure magnet 18a are such as to enable a user to open closure 14 using one or two fingers. It will be recognized that one or more magnets may be positioned in either neck groove 12b or at first closure end 12a. In alternate embodiments, a single magnet 18 may be used without magnet 18a or magnet 18a may be used without magnet 18. Also seen is receiving groove 13 in body 12.

FIG. 5 is a bottom perspective view of hook 10 in the closed position showing receiving groove 13 formed into body 12. Also seen is an alternate embodiment in which collar 25 is placed on hook 10 so as to enable it to slide over neck 12a and first closure end 14a. By sliding over and enclosing neck 12a and first closure end 14a, closure 14 is locked by preventing it from rotating around pivot 16 to the open position. The double arrow shows the axial sliding direction of collar 25 on neck 12a. In one embodiment, collar 25 is fabricated from ferromagnetic material which allows it to be held in the locking position by one or both of magnets 18 and 18a.

FIG. 6 is a side view of hook 10 demonstrating closure 14 in the open position. In the open position, closure 14 is rotated away from second end 19 to form space 30 between second end 19 and body 12. In the embodiment shown, region 14c is seen fitting into receiving groove 13. The arrows show the movement of each end of closure 14 from the open to the closed position. FIGS. 7A and 7B are top perspective and side perspective views, respectively, of hook 10 in the open position. FIG. 7A depicts the embodiment that includes magnet 18a fixedly attached to first closure end 14a. FIG. 7B shows magnet 18 in neck 12a with its surface exposed at neck groove 12b.

FIG. 8 is a top perspective view of hook 10 demonstrating the advantage of the magnetic closure 14. Loop 60 is enclosed by closed hook 10 within area 50. Although not seen in FIG. 8, persons of skill in the art will recognize that loop 60 is tied off to form a closed loop that prevents it from sliding out of area 50. It can be seen that any force pulling loop 60 against closure 14 will actually apply additional rotational closing force against ferromagnetic closure 14 driving it toward neck groove 12a and neck magnet 18. It

can also be seen that the arrangement of using force to hold closure **14** in the closed position provides an advantage over the prior art as it helps to prevent an item held by hook **10** ("hooked item") from slipping out of area **50** as opposed to a closure held in place by an axial spring as in the prior art which is easily opened.

Hook **10** is opened to receive a loop or other item by pushing closure **14** so as to rotate second closure end **14b** into enclosed area **50**. Magnet **18** can be sized to allow first closure end **14a** to be released easily by pushing with a finger. In contrast to spring-biased hook closures, the more closure **14** is pushed into area **50**, the easier it is to continue pushing because ferromagnetic first closure end **14a** is moved further from neck magnet **18**. The same principle applies if closure magnet **18a**, located in first closure end **14a**, is used with neck magnet **18** or alone. In addition, there is little snap or sudden closing of closure **14** as found in prior art hooks with biasing springs as the magnetic force only gradually increases as first closure end **14a** approaches magnet **18**. The distance for a sudden closing is limited to 2-3 mm.

FIG. **9** is a side view of hook **100** without a closure and including a lip opposite the neck groove of a second embodiment of the present invention. Hook **100** includes body **112**, neck **112a** proximate first body end **112e**, and second body end **119**.

Also seen in shaded view is neck groove **112b** including groove wall **112c** and lip **113** opposing neck groove **112b**. As seen in FIG. **9**, neck groove **112b** may extend into an inner surface of body **112** to form receiving groove **112d** for closure **114** (not seen in FIG. **9**) in the open position. Alternatively, receiving groove **112d** may be a separate groove. A receiving magnet may optionally be located in receiving groove **112d**. Lip **113** may preferably be integral with body **112** or attached with screws, rivets, adhesives in methods known to those having skill in the art. By integral is meant that the component parts are formed together as a single unit. Pivot **116** extends through body **112**. In a one embodiment, pivot pin **116** ("pin **116**") is circular, meaning its cross section does forms a circle. In shaded view, neck magnet **118** is seen embedded in neck groove **112b**. In one embodiment, neck magnet **118** is approximately 10 mm long, 3 mm wide, and 2 mm deep, however, persons having skill in the art will recognize that the size of magnet **118** can be changed depending on the size of hook **100** and the magnetic force desired. Similar to hook **10** described above, a ring may be attached to hook **100** using a swivel attachment that allows hook **100** to move through an arc. Persons of ordinary skill in the art will recognize that other types of attachments are suitable to hold the ring to hook **100**. Example of such attachments include, but are not limited to, pivot attachments as with ball and socket attachments and solid attachments. Examples of rings include, but are not limited to, o-rings, d-rings, chain attachments, handles, etc.

FIG. **10A** is a side view of one embodiment of closure **114**. First closure end **114a** and second closure end **114b** are on longitudinally opposite ends of closure **114**. Edge **117** is formed from first closure end **114a**. In one embodiment, offset **115** is formed from a portion of second closure end **114b** which includes extension **115a**. Region **114c** contacts an inner surface of body **112** when closure **114** is opened. In a preferred embodiment, region **114c** is received into receiving groove **112d** when closure **114** is opened. Closure **114** defines slot **116a** which is pivotally attached to pin **116**. In the embodiment shown, slot **116a** has an oval shape. FIG. **10B** is a side view of an alternate embodiment of closure **114** in which slot **116b** is keyhole shaped. Preferably, closure **114**

is fabricated from nonmagnetic material, more preferably, nonmagnetized ferromagnetic material.

FIG. **11** is a side view of hook **100** depicting closure **114** in the closed position i.e., spanning the space between second closure end **119** and hook body **112**. In the closed position, one curved end of oval slot **116a** is shown nested against or contacting pivot **116** with a gap **a** between pivot **116** and the opposing end of oval slot **116a**. Also shown is gap **a'** between groove wall **112c** and closure edge **117**. Gaps **a** and **a'** are approximately equal in size. Gap **b** is shown between offset **115** and second hook end **119** and is larger than gaps **a** and **a'**. Closure magnet **118a** is shown embedded in closure **114** proximate to first closure end **114a** opposite neck groove **112b**. It can be seen that neck magnet **118** and closure magnet **118a** are opposed to each other and also offset from each other. Preferably, magnets **118** and **118a** are the same size and have equal and opposite magnetic force (opposite polarity). By offset is meant that magnets **118** and **118a** do not align perfectly when closure **114** is in the closed position such that, for example, the ends of the two magnets do not align when closure **114** is closed. Neck magnet **118** and closure magnet **118a** are of opposite polarity and are used to hold closure **114** in the closed position by magnetic force. As seen in FIG. **11**, lip **113** is also used to retain closure **114** in the close position. Pin **116** is circular in shape.

In a preferred embodiment, closure magnet **118a** in closure **114** is offset preferably $\frac{1}{3}$ to $\frac{1}{2}$ of its length from neck magnet **118** when it is rotated to the closed position. Because the opposing sides of the offset alignment and opposing magnets **118** and **118a** are of opposite polarity, as magnet **118a** approaches magnet **118**, closure magnet **118a**, and consequently closure **114**, is pulled onto lip **113** by magnetic attraction from neck magnet **118** once closure end **114a** and closure magnet **118a** initially contact neck groove **112b**. It is also evident that extension **115a** must extend far enough to contact and preferably overlap, second end **119** in the closed position.

FIG. **12** is a side view of hook **100** in which closure **114** is pushed forward off lip **113**. Pivot **116** can be seen contacting the opposite curved end of oval shaped slot **116a**.

FIG. **13** is a side view of hook **100** showing closure **114** in the open position. Closure **114** is pivoted so that second closure end **114b** is lifted off second hook end **119**. To pivot closure **114** to the open position, closure **114** is slid or pushed forward generally toward second body end **119** by the user so that pivot **116** contacts the opposite end of the oval slot **116a** creating a gap **aa** which is approximately equal in length to gap **a** seen in FIG. **11** and smaller than gap **b**. It will be noted that this allows closure **114** to slide forward and off lip **113** thereby unlocking closure **114** from the closed position. Referring to FIG. **11**, it can be seen that the presence of gap **b** and offset **115** allows closure **114** to be pushed toward second hook end **119**. Because gap **b** is larger than either of gaps **a** and **a'**, first closure end **114a** can be pushed off lip **113** when closure **114** is pushed forward toward second hook end **119** until slot **116a** rests against pivot **116** because the greater size of gap **b** provides sufficient room to push closure **114** until first closure end **114a** is pushed off lip **113** allowing it to be rotated away from neck groove **112b**.

When closure **114** is rotated to the closed position, the opposite polarities of neck magnet **118** and closure magnet **118a** attract first closure end **114a** toward neck groove **112b** while the offset orientation of the magnets creates a pulling force that pulls first closure end **114a** onto lip **113** and afterwards continues to holds it between neck groove **112b** and lip **113**.

It can be seen that the structure of hook 100 helps to prevent the accidental opening of closure 114. A positive push of closure 114 toward second end 119 is required so that lip 113 no longer prevents its rotation into the open position. Significant also is the shape of slot 116a and the offset shape 115 of second closure end 114b. The offset shape allows second closure end 114b to contact second hook end 119 to keep hook 100 closed and still allow closure 114 to be pushed sufficiently forward to move first closure end 114a off lip 113 and to be rotated open. Therefore, hook 100 can hold items such as rings, ropes, etc. in the area defined by hook body 112 and closure 114 in the closed position. Because first closure end 114a rests between lip 113 and neck groove 112b, it is confined between hook neck 112a (and neck groove 112b) and lip 113 preventing it from accidentally opening.

FIG. 14 is a side view of hook 100 depicting an alternate embodiment of closure 114 with slot 116b having a keyhole shape with rectangular and circular portions and pivot 116' having an oval shape. Lip 113 may be removed from this second embodiment. Preferably, the size of oval pin 116b and the straight portion of keyhole slot 116' are sized so that closure 114 is locked into the closed position so that it cannot rotate when pin 116b is in the rectangular portion of keyhole slot 116'. This locking position of pin 116' is combined with the pulling and closing magnetic force between neck groove 112b and first closure end 114a, caused by the opposite polarity and offset positioning of neck magnet 118 and closure magnet 118a, which keeps closure 114 closed and prevents the accidental or inadvertent opening of hook 100.

FIG. 15 is a side view of the alternate embodiment of hook 100 showing closure 114 pushed toward second hook end 119. Oval pivot pin 116' is located in the wider circular portion of keyhole slot 116b after closure 114 is pushed the distance of gap a seen in FIG. 14. With oval pin 116b in the circular portion, closure 114 is able to rotate into the open position as the circular portion of slot 116' rotates around pin 116b. It will be recognized that by pushing closure 114 toward second hook end 119, closure magnet 118a is moved away from neck magnet 118. Because gap b is larger than gap a, there is sufficient clearance to allow closure 114 to be pushed so pivot 116' is in the circular portion of keyhole slot 116b enabling closure 114 to rotate open.

FIG. 16 depicts hook 110 provided with keyhole slot 116b in the open position. Pin 116' and the circular portion of slot 116b are sized to allow rotation or pivoting around pin 116' is sized to enable closure.

Finally, in both embodiments, a collar similar to collar 25 discussed above may enclose neck 112b and first end 114a of closure 114.

It can be seen that both forms of the alternate embodiment of hook 100 discussed above provide both a mechanical locking mechanism and a magnetic closing force on closure 114 in the closed position both of which are defeated by the ability to slide closure 114 forward because of the gaps configured in the pivotal connection of closure 114 to body 112 and between second closure end 112b and second end 119. The offset arrangement of neck magnet 118 and closure magnet 118a causes first closure end 114a to be automatically pulled into correct closing position without additional adjustment by the user.

FIGS. 17-20C depict an additional embodiment of the hook of the present invention. FIG. 17 is side view of hook 200 that includes body 212, neck 212b proximate first hook end 212a, and second hook end 219. Closure 214 is rotationally and slidably attached to pivot pin 216. Pivot pin 216

(“pin 216”) extends through slot 216a. In the preferred embodiment shown, slot 214a is oval and pin 216 is circular or cylindrical. Closure 214 is similar to closure 114 discussed above and comprises first closure end 214a with closure edge 217 formed from first closure end 214a. Second closure end 214b includes offset 215 which is formed from a portion of second closure end 214b. Second closure end 214b also includes offset surface 215a. In one embodiment, closure 214 is fabricated from nonferromagnetic material(s) such as nickel alloy. Gap 213 is between closure edge 217 and first hook end 212c. Inclined floor 213a forms a ramp (“ramp 213a”) that extends diagonally toward the closure side 200a of hook 200. Accessories, for example, rings, may be attached to first hook end 212a.

Second hook end 219 is configured to include an opposing offset surface 219a. In the closed position shown in FIG. 17, closure 214 spans the gap between hook body 212 and second hook end 219. It can be seen that in the closed position, offset surfaces 215a and 219a are opposed, i.e., contacting or almost contacting and facing in opposite directions. In the closed position, closure 214 and hook body 212 enclose space 250.

FIG. 18 is a side cross section view of hook 200. Magnet 218 is embedded or otherwise fixedly attached to neck groove 212c in such a way that it attracts opposing magnets or magnetized material. Magnet 218a is generally embedded near first closure end 214a and positioned to be directly aligned with magnet 218. Magnets 218 and 218a have opposite polarity making them mutually attractive. This mutual magnetic attraction holds closure 214 in the closed position with closure 214 reaching and contacting second hook end 219 as shown. In addition, opposing surfaces 215a and 219a contact each other in the closed position shown in FIG. 18. Neck groove 212c may extend past pin 216 into an inner surface of inner hook body 212 to form receiving groove 212d. As shown, receiving magnet 218b optionally may be placed in receiving groove 212d if closure 214 is formed at least partially from ferromagnetic material to make it attracted to magnets.

FIGS. 19A-C depict the movement of closure 214 from the closed to the open position. FIG. 19A is a side cross section view showing hook 200 in the closed position. Offset surfaces 219a and 115a are opposed to each other and preferably touching. It can be seen from the arrows that closure 214 and offset surface 115a rotates into the closed position from the closure side 200a. The length of the gap between the edge of pin 216 and the second end of slot 216a is designated as length a while the length of gap 213 is shown as length b. The length of offset surface 115a is shown as length c. It can be seen that length b is equal to or longer than length a. Length c is less than length a and thus also less than length b.

FIG. 19B shows hook 200 as closure 214 moves from the closed to the completely open position. First closure end 214a is moved through gap 213 toward first hook end 212a. This action can be achieved by the user's thumb or finger pulling closure through gap 213. It can be seen that as closure 214 is moved toward first hook end 212a, offset end 215 and offset surface 215a is moved from offset surface 219a toward pin 216. Because slot 216a is in the preferred oval shape and length a is greater than length c, closure 214 has sufficient clearance to move offset surface 215a completely away from offset surface 219a as depicted by the sight gap between offset 215 and second hook end 219.

As first closure end 214a is pulled through gap 213, it travels up ramp 213a. The angle of ramp 213a enables

11

closure magnet **218a** to be separated from neck magnet **218** thereby reducing the magnetic force holding hook **200** in the closed position.

FIG. 19C depicts hook **200** as it approaches the open position. Second closure end **214b** is approaching receiving groove **212d** to be received into receiving groove **212d**. The presence of receiving groove **212d** is not necessary but is preferred as nesting closure **214** into receiving groove **212d** provides a larger opening into defined area **250** between second hook end **219** and offset **215**. Magnets **218** and **218a** are separated amply to enable the user to easily hold closure **214** open, preferably by pressing second closure end **214b** into receiving groove **212d**.

FIG. 20A shows hook **200** returning to the closed position as shown by the arrows. User releases the pressure holding second closure end **214b** into receiving groove **212d**. Closure magnet **218a** has remained attracted to neck magnet **218** which starts first closure end **214a** rotating on pin **216** toward first hook end **212a** and gap **213**.

FIG. 20B shows hook **200** with offset **215** clearing second hook end **219** at the same time first closure end **214a** and closure edge **217** return to gap **213**. After offset **215** rotates past second hook end **219**, edge **217** starts to slide down ramp **213a**, pulled by the magnetic attraction between closure magnet **218a** and neck magnet **218**.

The arrangement of ramp **213a** and the magnets enables closure **214** to return to the closed position with magnets **218** and **218a** aligned and holding first closure end **214a** to neck groove **212c** and offset **215a** contacting opposing offset surface **219a** as seen in FIG. 20C.

In a preferred embodiment of hook **200**, closure **214** has the angled shape shown in FIGS. 17-21 in which a first closure portion between closure edge **217** and slot **216a** extends approximately perpendicularly from plane P extending through first hook end **212a**. A second closure portion extends from slot **216a** to second hook end **219** at a nonperpendicular angle relative to plane P. This provides for maximum space **250**. In a more preferred embodiment, closure **214** rapidly and automatically returns to the closed position with magnets **218** and **218a** aligned in neck groove **212c** and offsets **219a** and **215a** opposed to and contacting each other. As seen in FIG. 20B, this rapid closing movement requires clearance of offset end **215** before first closure end **214a** is nested in neck groove **212c**. The incline of ramp **213a** advantageously delays the closing rotation of closure **214** while simultaneously continuing the outward rotation of closure **214** and pushing it offset **215a** toward second hook end **219** and offset **219a**. Toward this end, the oval shape of slot **216a** provides the space to enable closure **214** to move toward second hook end **219** as well as the space to move closure **214** away from second hook end **219** when it is opened.

FIG. 21 depicts a preferred embodiment in which slot angle s is less than ramp angle r relative to plane P. In one preferred embodiment, angle s is approximately one half the angle of ramp angle r . To utilize an angled closure **214** as shown in the drawings and described above, angle r must be greater than angle s to ensure closure **214** will rotate properly in toward space **250**. The closer to equivalence angles r and s become, slot **216** will slide closer to a track that is parallel to neck **212b** making closure **214** difficult to rotate properly.

FIGS. 22-28A depict a second additional embodiment of the hook of the present invention. FIG. 22 is a side view of hook **300** including body **312**, neck **312b**, which is proximate first hook end **312a**, and second hook end **318**. Preferably, hook **300** is fabricated from nonferromagnetic mate-

12

rial. Attachment means **302** is attached to hook **300** at the end of first hook end. Examples of attachment means **302** are, but not limited to, D-rings, posts with or without a tie-off hole, swivel rings, etc. Second hook end **318** includes j-hook **319**. Neck **312b** has an outer surface **311** ("surface **311**") and an opposing inner surface **313** ("surface **313**"). Surface **313** includes center ridge **320** that extends from first hook end **312a** to form flange **322**. Flange **322** extends to angled portion **324** of hook body **312**. Flange **322** includes oblique portions **322a** and **322b**, respectively, and also defines slot **326**. Preferably, slot **326** includes two legs **326a** and leg **326b** with the former having a bend in its length and pointed at angled portion **324**. Center ridge **320** has a flat top surface **328** (not clearly seen in FIG. 22) in which hook magnet **327** is embedded in such a way that one face is exposed on top surface **328** or is embedded so that its magnetic force is not diminished by top surface **328**. FIG. 22A is an enlarged side view of the portion of FIG. 22 enclosed in area **22A** showing more clearly legs **326a** and **326b** of slot **326** as well as the orientation of slot **326** in flange **322**. Flange **322** includes first oblique surface **322a** and second oblique surface **322b**.

FIG. 23A is a front view of closure **330** having first closure end **332** and second closure end **334** while FIG. 23B is a side view of closure **330**. As seen in FIG. 23A, first lateral side **336** and second lateral side **338** (collectively "lateral sides"), which each include opposing legs **336a** and **338a**, respectively, form opposing sides of closure **330** extending from first closure end **332** to second closure end **334**. Bridge **340** extends between lateral sides **336** and **338** at or proximate second closure end **334**. Closure magnet **337** is embedded in the floor of channel **339** formed by lateral sides **336** and **338** in such a way as to have a surface exposed to utilize its magnetic attractive force. Sloping channel **339a** and plateau **339b** are included in the floor of channel **339**. Opposing pairs of pin holes **342a** and **342b** are defined by lateral sides **336** and **338**. As described below, paired pin holes **342a** and/or **342b** each receive a pin that extends between lateral sides **336** and **338**. Thus, closure **330** may have one or, preferably, two pins. Closure **330** is able rotate around the pin(s).

The side view seen in FIG. 23B shows closure **330** with first lateral side **336** facing up out of the drawing sheet. Seen in shadow is closure magnet **337** embedded in channel **339** as well as sloping channel **339a** and plateau **339b** which are both part of channel **339** extending between sides **336** and **338**. Also seen are pin holes **342a** and **342b** defined by first lateral side **336** and bridge attachment position **340a**. Bridge **340** is fixedly attached to legs **336a** and **336b**, respectively, of lateral sides **336** and **338** by glue, plastic or metal welding, friction fitting, or other suitable methods well known to those having skill in the art. Optional traction surface(s) **344** may be added to the surface opposing channel **339** to enable pushing of closure **330** when a user opens hook **300** as explained below. Traction surface **344** may be knurls as shown, a roughened surface(s) similar to sandpaper, ridges, or other forms familiar to those having skill in the art.

FIGS. 24-28A are lengthwise cross section views depicting the movement of closure **330** relative to hook body **312**, particularly center ridge **320**, flange **322** and slot **326**, when hook **300** is opened. FIG. 24 depicts hook **300** in the closed position. J-hook **319** includes angled sliding surface **319a** and notch **319b** which holds bridge **340**. A j-hook is defined as a notch or indentation having the form of the letter "J" with the curved portion of the notch receiving the device or component to be held. First or upper pin **346** and second or lower pin **347** (collectively pins **346** and **347**) are slidingly

13

engaged in leg 326b of slot 326. By slidably engaged is meant that pins 346 and 347 slide freely within both legs of slot 326 when closure 330 is moved by a user. Closure 330 also rotates around pins 346 and/or 347. Hook magnet 327 and closure magnet 337 face each other and have opposite polarity to enable the releasable magnetic attraction of first hook end 312a with first closure end 332 when hook 300 is closed. Although it is preferable to utilize opposing magnets in closure 330 and inner surface 313, persons of skill in the art will recognize that either hook magnet 327 or closure magnet 337 may be replaced by a suitable segment of ferromagnetic material to releasably hold the opposing magnet. Hook 300 encloses defined area 350 when closed.

FIG. 24A is an enlarged view of area 24A of FIG. 24. In the closed position, it can be seen that sloping channel 339a of closure 330 rests against oblique portion 322a of flange 322. In the closed position, second notch 321 is formed by second closure end 334 and j-hook 319 which advantageously provides an indentation to hold rope, cord, twine, wire, or other similar objects in such a way that they will rest in second notch 321 and press on second closure end 334 to keep it in the closed position.

FIGS. 25 and 25A show the first movement of closure 330 to open hook 300. The opening of hook 300 is started by pushing closure 330 toward second hook end 319 as indicated by arrow A. Simultaneously, pins 346 and 347 slide upward along slot leg 326b of slot 326 and sloping channel 339a slides upward along oblique portion 322a at the same or approximately same angle as slot leg 326b. Bridge 340 is lifted out of notch 319b. This upward angled movement starts to separate magnets 337 and 327 or, alternatively, starts to separate a magnet from an opposing ferromagnetic segment. Second notch 321 starts to shorten in length as second end 334 moves toward sliding surface 3419a.

FIGS. 26 and 26A portray the position of closure 330 relative to hook 300 when first pin 346 reaches the end of slot leg 326b, i.e., at the junction of slot legs 326a and 326b. Closure 330 is sized relative to hook body 312 so that when first pin 346 slides to the end of slot leg 326b, second closure end 334 contacts sliding surface 319a of j-hook 319. At the same time, magnets 337 and 327 are separated further as sloping channel 332a is moved further along oblique portion 322a making it easier to open hook 300 as the magnetic attraction between magnets 337 and 327 weakens.

FIGS. 27 and 27A depict the rotational movement of closure 330 relative to hook body 312 when bridge 340 is moved out of j-hook 319. As closure 330 continues to be pushed upward in the direction of arrow A, second closure end 334 contacts and slides along sliding surface 319a. The angle of sliding surface 319a causes second closure end 334 to rotate away from j-hook 319 as indicated by arrow B. This rotation causes first pin 346 to slide into slot leg 326a while simultaneously closure 330 rotates around second pin 347. Sloping channel 339a pivots or rotates around the distal end of oblique portion 322a (the end farthest from magnet 327). This movement further separates magnets 337 and 327.

FIGS. 28 and 28A depict the position of closure 330 relative to hook body 312 when closure 330 is completely opened. First pin 346 slides along slot leg 326a toward angled portion 324 of flange 322. Preferably, slot leg 326a has been sized to have pin 346 contacting the end of slot leg 326a. Sloping channel 339a rests against second oblique portion 322b, while leg 336a rests against angled portion 324 of flange 322. When closure 330 is released, it will reverse the movements described above to move back to the closed position seen in FIGS. 24 and 24A.

14

The above described contact surfaces for closure 330 and flange 322 provide the advantage of supplying the user with stable surfaces for holding closure 330 in the open position while an object is placed in or removed from defined area 350. In addition, the rotatable attachment of closure 330 to second pin 347 has the advantage of providing greater stability to closure 330 when it is held in the open position as closure 330 can rotate around pin 347 while pin 347 is held within slot leg 326b thereby reducing or eliminating any lateral movement of closure 330 when it is being held open. Also, persons of skill in the art will realize that the presence of second pin 347 will diminish or remove the lateral movement of closure 330 when it moves to the closed position as pin 347 is confined to slot leg 326b. Upon release of closure 330, this enables first closure end 332 to rotate such that closure magnet 337 contacts hook magnet 327 without the need for additional adjustment after the closing movement is completed.

Preferably, hook 300 is configured such that center ridge 320 fits into channel 339 between lateral sides 336 and 338 and hook magnet 327 is opposite from and contacting closure magnet 337. This configuration provides the advantage of protecting the magnets or alternatively, one magnet and opposing ferromagnetic material from such elements such as rain, dust, mud, etc.

Thus it is seen that the objects of the invention are efficiently obtained, although changes and modifications to the invention should be readily apparent to those having ordinary skill in the art, which changes would not depart from the spirit and scope of the invention as claimed.

I claim:

1. A hook comprising:

- a body formed into a hook shape and fabricated from nonferromagnetic material, said body having a first hook end and a second hook end, a neck, and an angled portion, wherein said neck is proximate to said first hook end;
- a center ridge extending along one side of said neck, one end of said ridge forming a flange that reaches to said angled portion, said center ridge having a flat top surface;
- an angled slot defined by said flange and having a two slot legs;
- a closure having a first closure end and a second closure end and a first lateral side and a second lateral side, each lateral side extending the length of said closure;
- a channel having a floor and extending at least partly between the lengths of said first lateral side and said second lateral side;
- at least one pin rotatably attached to said first and second lateral sides;
- a bridge proximate to said second closure end and attached to said first and second lateral sides; and
- at least one first magnet attached to either said top surface of said center ridge proximate to said first hook end or said floor of said channel proximate said first closure end,
- wherein said at least one pin is slidably engaged with said slot, and said hook encloses a defined area in a closed position.

2. The hook as recited in claim 1 wherein said at least one pin is two pins.

3. The hook as recited in claim 2 further comprising a ferromagnetic material attached to said hook and positioned to contact said at least one first magnet in a closed position.

15

4. The hook as recited in claim 1 further comprising at least one second magnet attached to said hook and positioned to contact said at least one first magnet in a closed position.

5. The hook as recited in claim 4 further comprising at least one second magnet attached to said hook and positioned to contact said at least one first magnet in a closed position.

6. The hook as recited in claim 1 further comprising a ferromagnetic material attached to said hook and positioned to contact said at least one first magnet in a closed position.

7. The hook as recited in claim 1 wherein said second hook end is formed into a j-hook.

8. The hook as recited in claim 7 wherein said bridge engages said j-hook in said closed position.

9. The hook as recited in claim 7 wherein said second hook end includes a notch when said hook is in said closed position.

16

10. The hook as recited in claim 7 wherein said j-hook includes a sliding surface opposite said second closure end.

11. The hook as recited in claim 1 further comprising a traction surface on said closure.

12. The hook as recited in claim 1 wherein said flange includes at least one oblique surface.

13. The hook as recited in claim 1 configured such that said center ridge fits into said channel between said first lateral side and said second lateral side.

14. The hook as recited in claim 1 wherein said floor of said channel includes a sloping surface.

15. The hook as recited in claim 1 wherein said two slot legs are unequal in length.

16. The hook as recited in claim 1 wherein said two slot legs are joined to form an acute angle.

* * * * *