



US00D459681S

(12) **United States Design Patent**
Turcotte

(10) **Patent No.:** **US D459,681 S**
(45) **Date of Patent:** **** Jul. 2, 2002**

(54) **DUMP BODY FOR A TRUCK**
(75) Inventor: **Jocelyn J. Turcotte**, Gatineau (CA)
(73) Assignee: **Les Ateliers Beau-Roc Inc.**, Vars (CA)
(**) Term: **14 Years**

D429,662 S * 8/2000 Smith et al. D12/93
D431,498 S * 10/2000 Smith et al. D12/93
D445,067 S * 7/2001 Musso, Jr. et al. D12/15
D450,627 S * 11/2001 Musso, Jr. et al. D12/15
D450,628 S * 11/2001 Musso, Jr. et al. D12/15

* cited by examiner

Primary Examiner—Stacia Cadmus

(74) *Attorney, Agent, or Firm*—Simpson & Simpson, PLLC

(21) Appl. No.: **29/146,171**
(22) Filed: **Aug. 6, 2001**

(57) **CLAIM**

The ornamental design for a dump body for a truck, as shown and described.

(30) **Foreign Application Priority Data**
Aug. 8, 2001 (CA) 2001-0326

DESCRIPTION

(51) **LOC (7) Cl.** **12-08**
(52) **U.S. Cl.** **D12/15; D12/93**
(58) **Field of Search** D12/1, 15, 93,
D12/98, 196; 298/11, 23 C, 23 M; 296/56,
57.1, 184, 291; 414/476-477, 480

FIG. 1 is a front perspective of a dump body for a truck, showing my new design;
FIG. 2 is rear perspective view thereof;
FIG. 3 is an enlarged front view thereof;
FIG. 4 is an enlarged rear view thereof;
FIG. 5 is a top view thereof;
FIG. 6 is a bottom view thereof;
FIG. 7 is a left side view thereof, it being understood that the right is a mirror image thereof; and,
FIG. 8 is a front perspective view thereof with the side panel shown in a lowered position.

(56) **References Cited**
U.S. PATENT DOCUMENTS
D289,748 S * 5/1987 Proeschl D12/15
D309,816 S * 8/1990 Morrow, Sr. D12/15 X
D386,128 S * 11/1997 Gerding et al. D12/93
D386,722 S * 11/1997 Dunphy D12/93
D414,138 S * 9/1999 McKinney D12/15 X

1 Claim, 4 Drawing Sheets

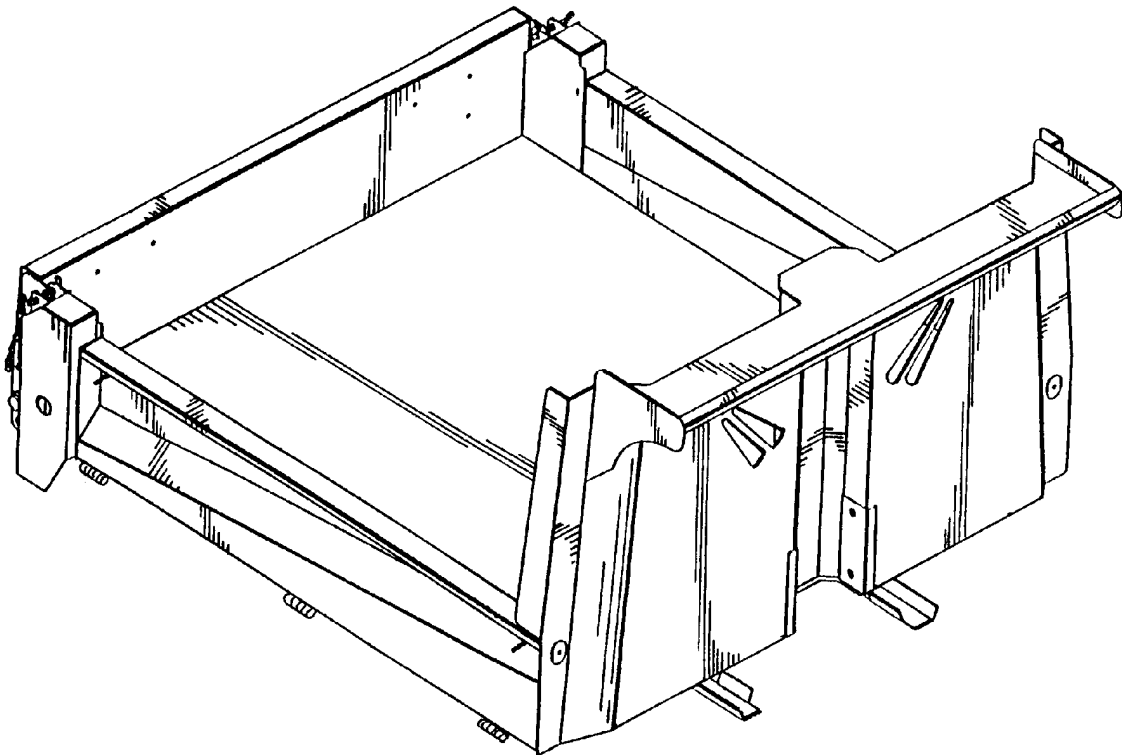

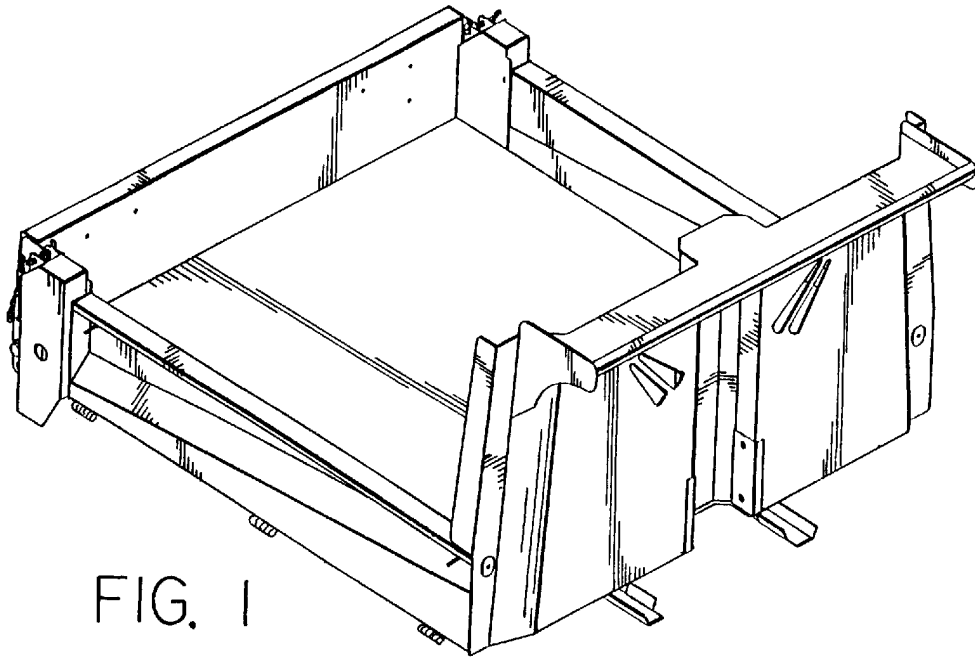

FIG. 1

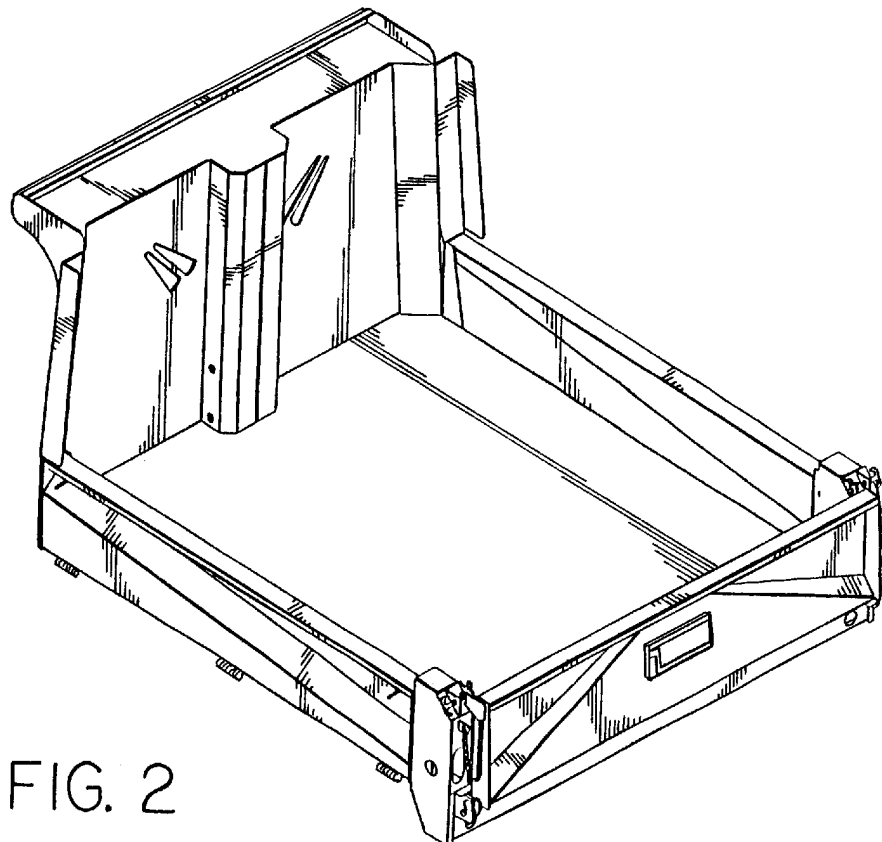

FIG. 2

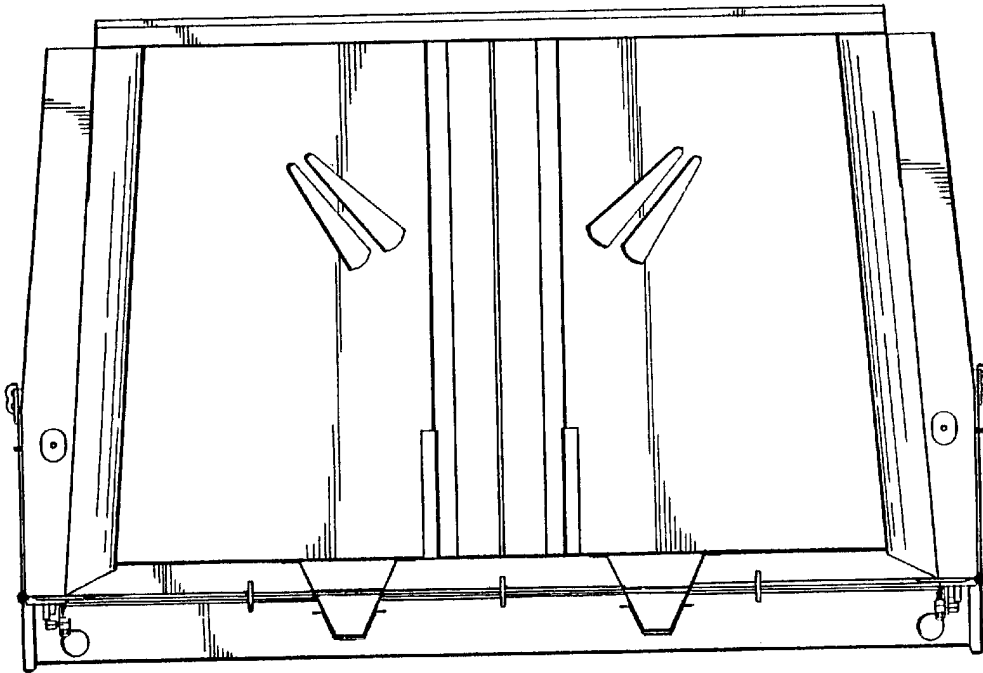

FIG. 3

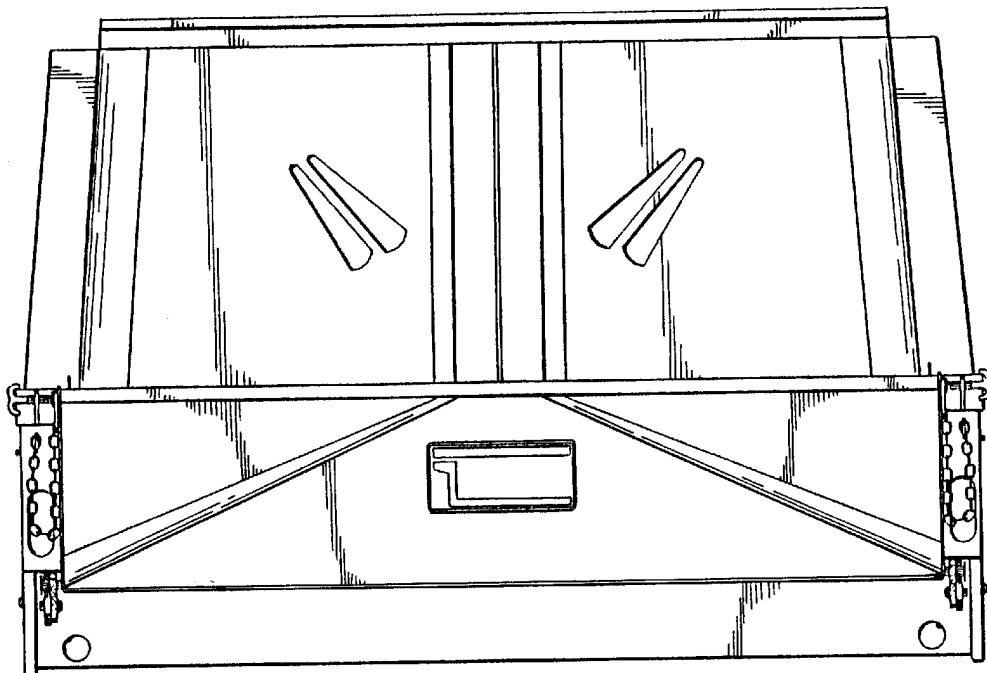

FIG. 4

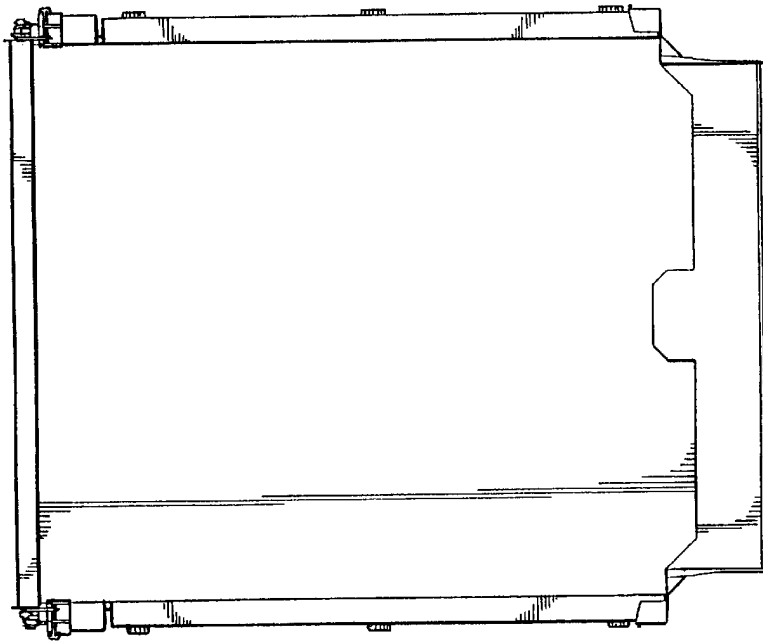

FIG. 5

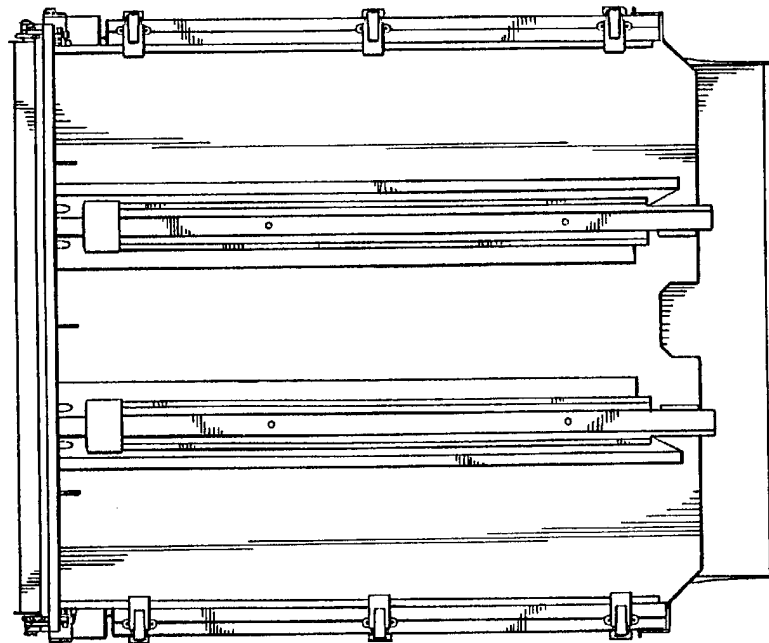

FIG. 6

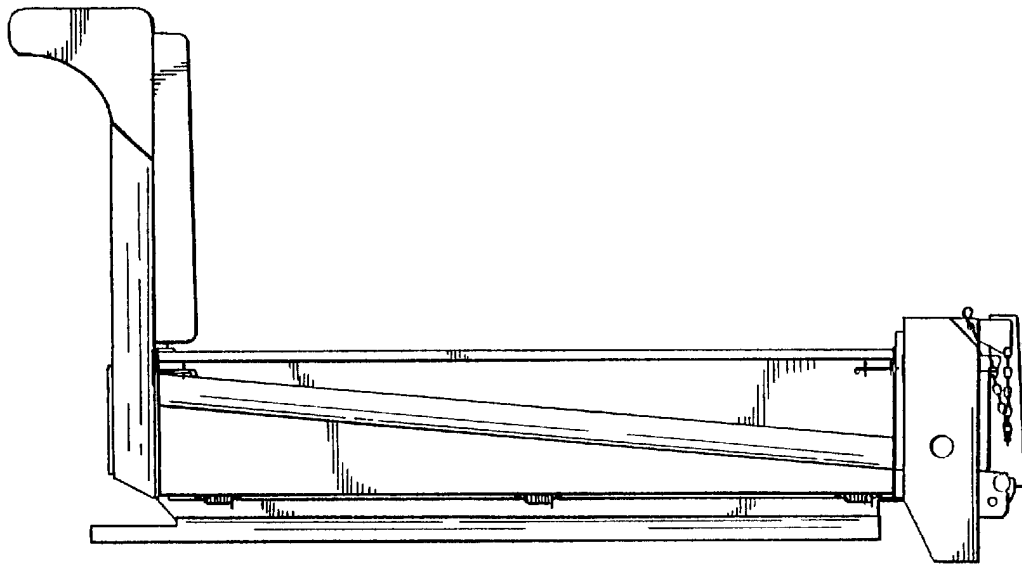

FIG. 7

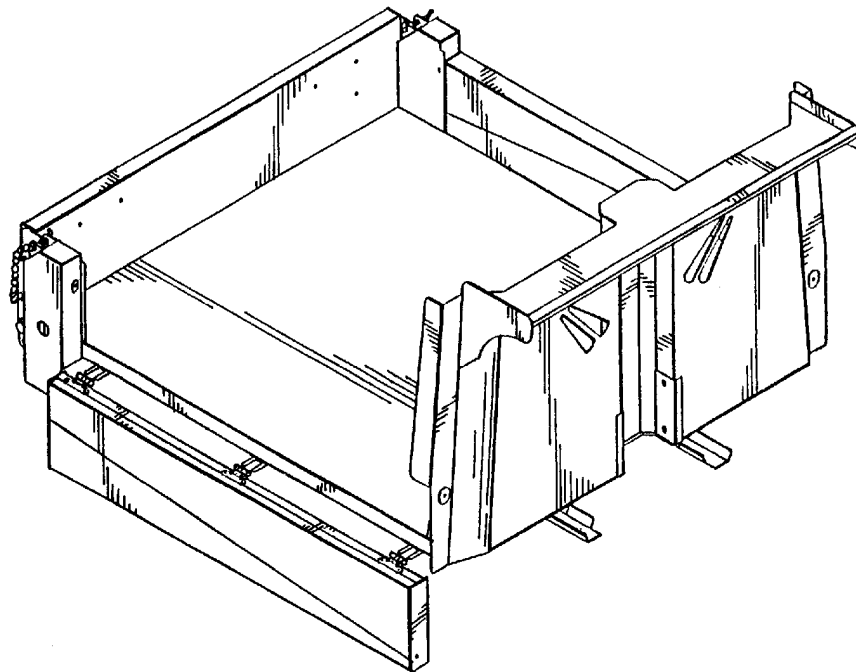

FIG. 8