



US00D501026S

(12) **United States Design Patent** (10) **Patent No.:** **US D501,026 S**
Ara (45) **Date of Patent:** **** Jan. 18, 2005**

- (54) **ALBUM**
- (75) **Inventor:** **Fiona Ara**, Toronto (CA)
- (73) **Assignee:** **Umbra Inc.**, Buffalo, NY (US)
- (**) **Term:** **14 Years**
- (21) **Appl. No.:** **29/185,829**
- (22) **Filed:** **Jul. 3, 2003**

5,676,482 A	10/1997	Hawkins	402/79
5,944,080 A	8/1999	Podwika	150/147
6,108,952 A	8/2000	Whittlef	40/124
6,155,602 A	12/2000	Mylander et al.	281/42
6,254,135 B1	7/2001	Girard	281/21.1
6,308,988 B1	10/2001	Mylander et al.	281/42
6,312,183 B1	11/2001	Arnold	402/79
6,347,810 B1 *	2/2002	Dottel	281/29
6,431,606 B1	8/2002	Lowe et al.	281/38
D462,517 S *	9/2002	Knox et al.	D3/271
D465,087 S *	11/2002	Shapiro	D3/303

- (51) **LOC (7) Cl.** **19-04**
- (52) **U.S. Cl.** **D19/26**
- (58) **Field of Search** D3/303; D19/26,
D19/27, 28, 29, 30, 31, 32, 33; 206/472;
281/15.1, 21.1, 22, 29, 30, 31, 38, 40; 283/64;
402/1, 3, 4, 22, 23, 24, 70, 73, 74, 500,
501

* cited by examiner

Primary Examiner—Joel Sincavage
Assistant Examiner—Elizabeth Albert
(74) *Attorney, Agent, or Firm*—Simpson & Simpson, PLLC

(56) **References Cited**

U.S. PATENT DOCUMENTS

187,448 A *	2/1877	Breed	281/22
460,090 A	9/1891	Fitzpatrick et al.	
868,458 A	10/1907	Lentz	
1,887,530 A *	11/1932	Trussell	402/77
1,966,570 A	7/1934	Weatherford	129/16
3,789,526 A	2/1974	Lavinson	40/124
4,241,955 A	12/1980	Armistead	312/12
4,356,652 A	11/1982	Schneider	40/530
4,852,280 A	8/1989	Beattie	40/124
D311,220 S *	10/1990	Kam	D19/26
D359,507 S *	6/1995	Schmidt	D19/26
5,529,418 A	6/1996	Alotta	402/73
5,573,276 A	11/1996	Nomura et al.	281/48

(57) **CLAIM**

The ornamental design for an album, as shown and described.

DESCRIPTION

FIG. 1 is a top perspective view of the album of the invention;
FIG. 2 is a bottom perspective view of the album of the invention;
FIG. 3 is an end view of the album of the invention in a closed arrangement; and,
FIG. 4 is an end view of the album of the invention similar to that of FIG. 3 except with the album opened.
The broken lines shown in FIGS. 1 and 2 of the drawings represent a pattern of stitching.

1 Claim, 3 Drawing Sheets

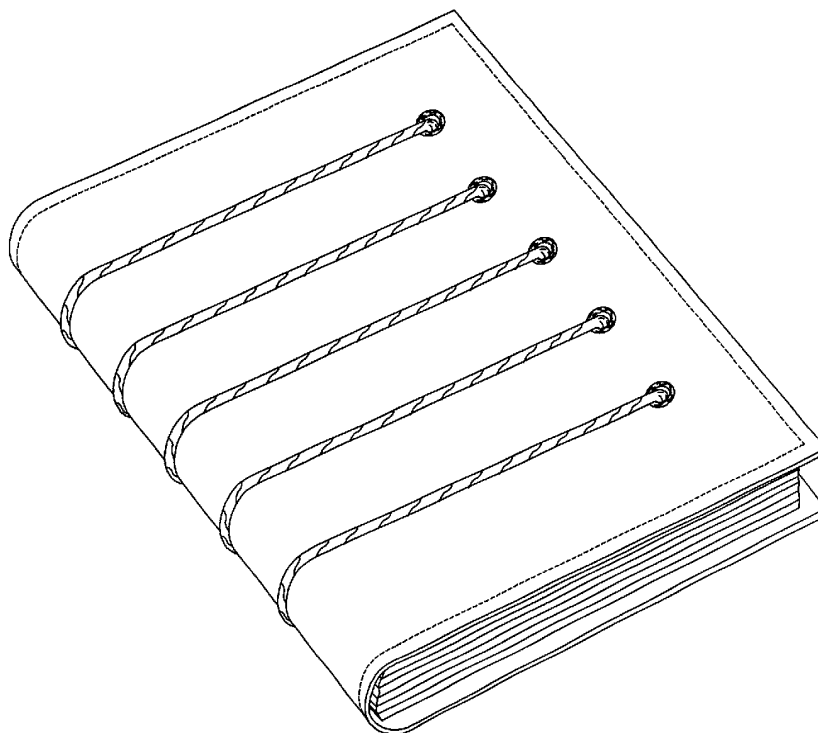

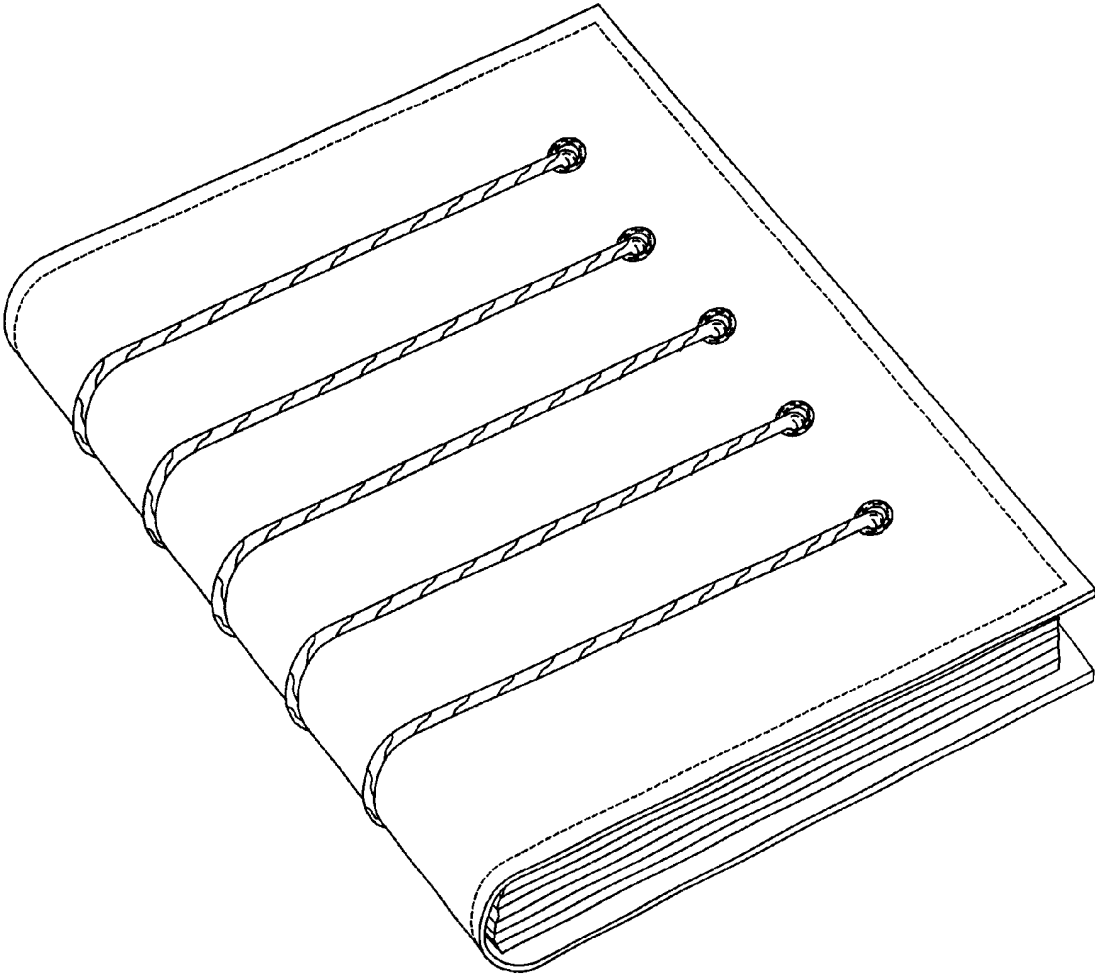

Fig. 1

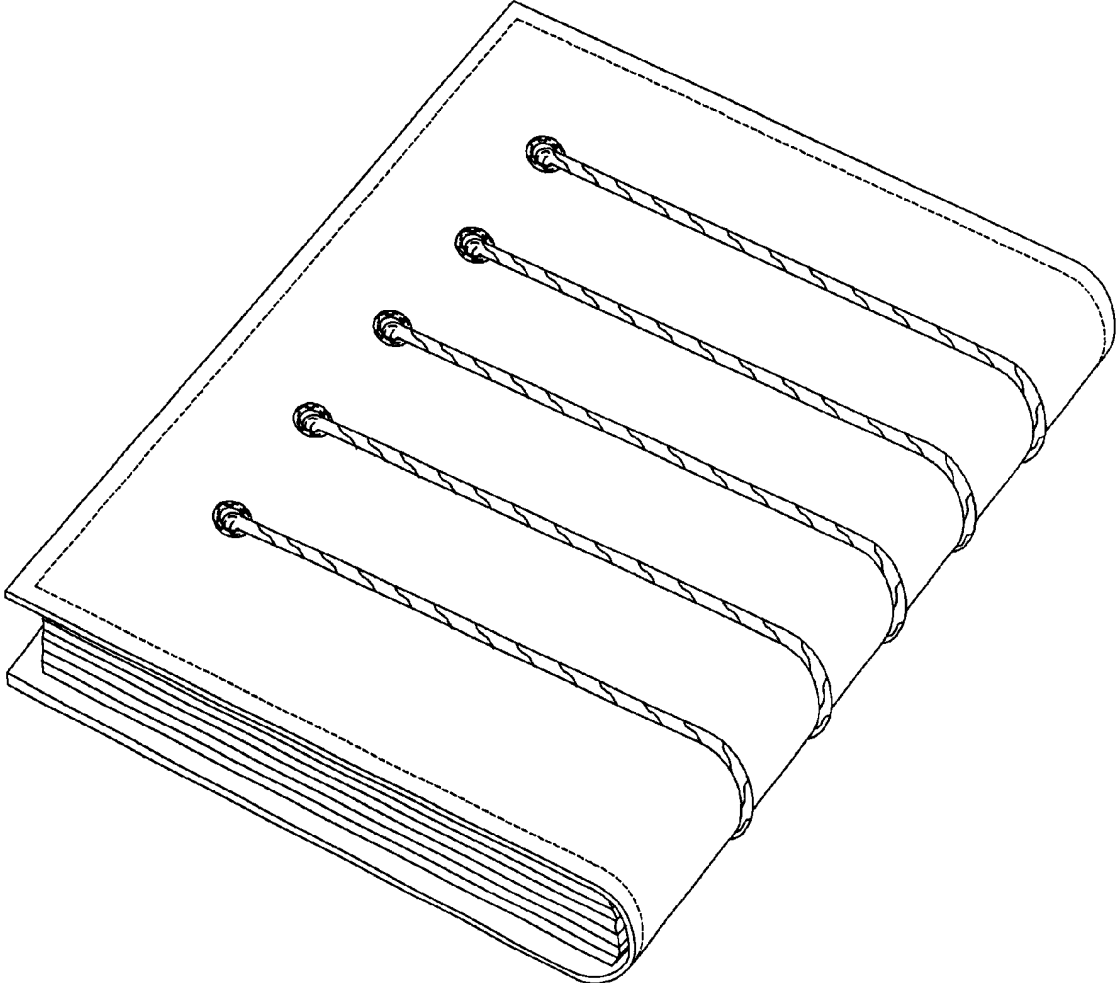

Fig. 2

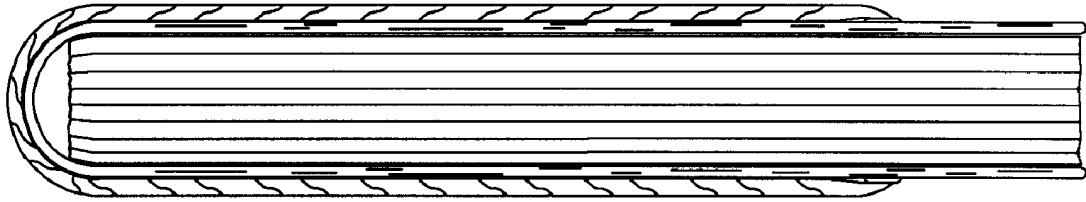

Fig. 3

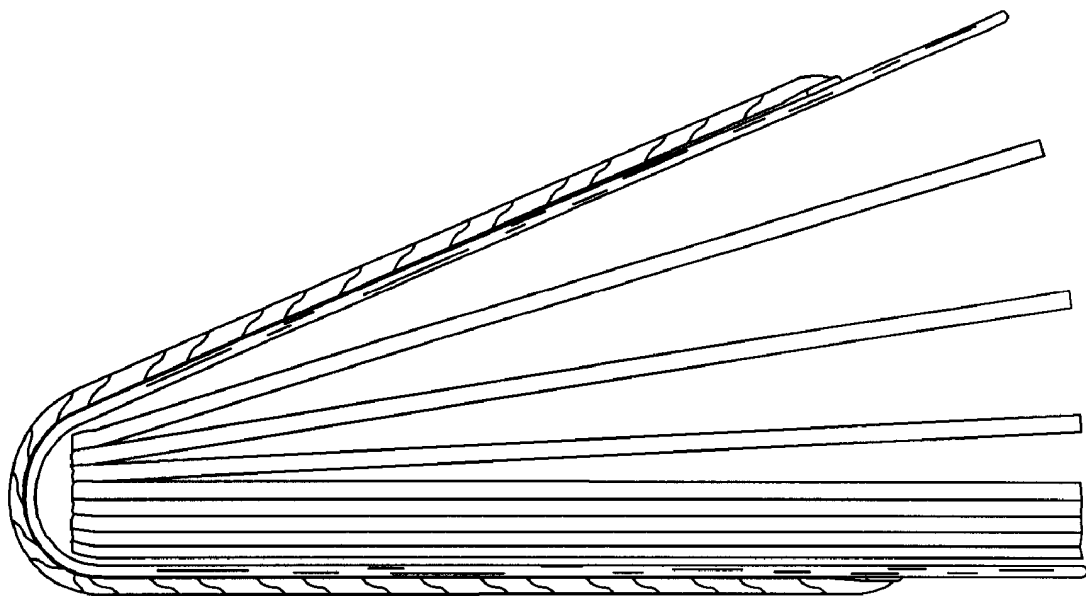

Fig. 4